

# CHAIN SPROCKETS FOR CONVEYORS AND ELEVATORS

**CHAIN SPROCKETS FOR CONVEYORS AND ELEVATORS**

## CHAIN SPROCKETS P50 R 25 - 31

### CHAIN

Pitch	50	mm
Inner width	11,5	mm
Roller Ø	25	mm
Plate thickness B <sub>1</sub>	10,5	mm

### CHAIN

Pitch	50	mm
Inner width	15	mm
Roller Ø	31	mm
Plate thickness B <sub>1</sub>	13,8	mm

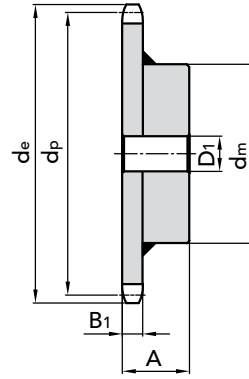

### CHAIN SPROCKETS P50

### ROLLER 25

### ROLLER 31

Z	d <sub>e</sub>	d <sub>p</sub>	PART NUMBER	D <sub>1</sub>	d <sub>m</sub>	A	kg.	PART NUMBER	d <sub>e</sub>	d <sub>p</sub>	D <sub>1</sub>	d <sub>m</sub>	A	kg.
6	115,0	100,0	14502506	20	60	40,5	1,11	14503106	116,2	100	20	60	43,8	1,18
7	132,7	115,24	14502507	20	60	40,5	1,37	14503107	133,8	115,24	20	60	43,8	1,44
8	148,1	130,6	14502508	20	60	40,5	1,55	14503108	152,3	130,6	20	60	43,8	1,72
9	163,7	146,2	14502509	20	60	40,5	1,89	14503109	167,9	146,2	20	60	43,8	2,05
10	179,3	161,85	14502510	25	90	43,3	3,10	14503110	183,5	161,85	25	90	46,6	4,40
11	195,0	177,5	14502511	25	90	43,3	3,44	14503111	199,2	177,5	25	90	46,6	3,80
12	211,0	193,2	14502512	25	90	43,3	4,79	14503112	212,0	193,2	25	90	46,6	4,30
13	226,4	208,95	14502513	30	90	43,3	4,17	14503113	230,6	208,95	30	90	46,6	4,78
14	242,2	224,7	14502514	30	90	43,3	4,63	14503114	246,4	224,7	30	90	46,6	5,37
15	257,9	240,45	14502515	30	90	43,3	5,09	14503115	262,1	240,45	30	90	46,6	5,98
16	273,8	456,3	14502516	30	110	55,4	8,26	14503116	278,0	256,3	30	110	58,7	9,05
17	289,5	272,05	14502517	30	110	55,4	9,10							
18	305,4	287,95	14502518	30	110	55,4	9,26	14503118	309,6	287,95	30	110	58,7	10,30
19								14503119	325,5	303,8	30	110	58,7	11,10
20	337,1	319,6	14502520	30	110	55,4	10,42	14503120	341,3	319,6	30	110	58,7	11,90
21	352,9	335,45	14502521	30	110	55,4	11,71							
22								14503122	373,0	351,35	30	110	58,7	13,54
23								14503123	388,9	367,2	30	110	58,7	14,38
24	400,0	383,05	14502524	30	110	55,4	13,00	14503124	404,7	383,05	30	110	58,7	15,35
25	416,4	398,95	14502525	30	110	55,4	13,98	14503125	419,7	398,95	30	110	58,7	16,40
26	432,3	414,8	14502526	30	133	61,1	15,20	14503126	436,5	414,8	30	133	64,4	18,81
27	448,2	430,7	14502527	30	133	61,1	17,03	14503127	452,4	430,7	30	133	64,4	19,00
28	464,0	446,55	14502528	30	133	61,1	18,62	14503128	468,2	446,55	30	133	64,4	21,00
30	495,8	478,35	14502530	30	133	61,1	20,29							
32								14503132	531,8	510,1	30	133	64,4	25,93
35								14503135	579,5	557,8	30	133	64,4	28,40
38	622,9	605,45	14502538	30	133	61,1	26,97	14503138	622	605,45	30	133	64,4	32,10

ALL THE CHAIN SPROCKETS FOR TRANSPORTERS AND ELEVATORS ARE REALIZED WITH WELDED HUB.

CAD drawings available on our site  
[www.chiaravalli.com](http://www.chiaravalli.com)

Quantity, availability and prices  
 on B2B Chiaravalli



## CHAIN SPROCKETS P75 R 31

### CHAIN

Pitch	75	mm
Inner width	15	mm
Roller Ø	31	mm
Plate thickness B <sub>1</sub>	13,8	mm

## CHAIN SPROCKETS P75 ROLLER 31

Z	d <sub>e</sub>	d <sub>p</sub>	PART NUMBER	D <sub>1</sub>	d <sub>m</sub>	A	kg.
8	217,6	195,98	14753108	30	90	46,6	4,52
9	241	219,3	14753109	30	90	46,6	5,36
10	264,4	242,77	14753110	30	110	58,7	8,70
11	287,9	266,25	14753111	30	110	58,7	9,60
12	311,5	289,8	14753112	30	110	58,7	10,73
13	334,1	313,42	14753113	30	110	58,7	11,83
14	358,7	337,05	14753114	30	110	58,7	11,83
15	382,3	360,67	14753115	30	110	58,7	14,45
16	406,1	384,45	14753116	30	133	64,4	17,43
17	429,7	408,07	14753117	30	133	64,4	17,43
21	524,8	503,17	14753121	30	133	64,4	26,07
25	620,1	598,42	14753125	30	133	64,4	26,07

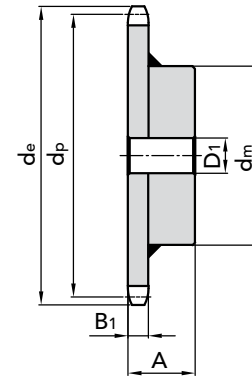

## CHAIN SPROCKETS P100 R 31 - 40

### CHAIN

Pitch	100	mm
Inner width	15	mm
Roller Ø	31	mm
Plate thickness B <sub>1</sub>	13,8	mm

### CHAIN

Pitch	100	mm
Inner width	22	mm
Roller Ø	40	mm
Plate thickness B <sub>1</sub>	20	mm

ALL THE CHAIN SPROCKETS FOR TRANSPORTERS AND ELEVATORS ARE REALIZED WITH WELDED HUB.

## CHAIN SPROCKETS P100 ROLLER 31

## ROLLER 40

Z	d <sub>e</sub>	d <sub>p</sub>	PART NUMBER	D <sub>1</sub>	d <sub>m</sub>	A	kg.	PART NUMBER	d <sub>e</sub>	d <sub>p</sub>	D <sub>1</sub>	d <sub>m</sub>	A	kg.
8	282,9	261,31	14993108	30	110	58,7	9,67	14994008	283	261,31	30	110	65	11,97
9	314,1	292,4	14993109	30	110	58,7	10,95	14994009	314	292,4	30	110	65	14,04
10	345,4	323,61	14993110	30	110	58,7	12,63	14994010	345	323,61	30	110	65	16,35
11	376,7	354,95	14993111	30	110	58,7	12,14	14994011	378	354,95	30	110	65	18,82
12	408,1	386,4	14993112	30	110	58,7	16,51	14994012	409	386,4	30	110	65	21,58
13	439,6	417,9	14993113	30	110	58,7	18,51							
14								14994014	473	449,4	30	110	65	28,14
15														
16	534,3	512,6	14993116	30	133	64,4	27,16	14994016	536	512,6	30	133	70,6	33,87
17	565,8	544,1	14993117	30	133	64,4	30,01							
18	597,6	575,9	14993118	30	133	64,4	51,20							
19														
20								14994020	663	639,2	30	133	70,6	48,50



## PLATEWHEELS P50 R 25 - 31

### CHAIN

Pitch	50	mm
Inner width	11,5	mm
Roller Ø	25	mm
Plate thickness B <sub>1</sub>	10,5	mm

### CHAIN

Pitch	50	mm
Inner width	15	mm
Roller Ø	31	mm
Plate thickness B <sub>1</sub>	13,8	mm

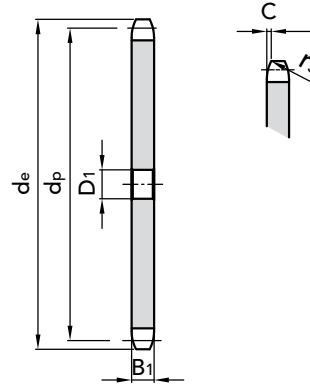

### ROLLER 25

Z	D <sub>1</sub>	P. NUMBER	d <sub>e</sub>	d <sub>p</sub>	kg.
6	20	24502506	115	100	0,55
7	20	24502507	132,7	115,24	0,76
8	20	24502508	148,1	130,6	0,92
9	20	24502509	163,7	146,2	1,30
10	25	24502510	179,3	161,85	1,45
11	25	24502511	195	177,5	1,94
12	25	24502512	211	193,2	2,01
13	30	24502513	226,4	208,95	2,33
14	30	24502514	242,2	224,7	3,06
15	30	24502515	257,9	240,45	3,80
16	30	24502516	273,8	256,3	4,00
17	30	24502517	289,5	272,05	4,20
18	30	24502518	305,4	287,95	5,10
19	30	24502519	321,3	303,8	6,00
20	30	24502520	337,1	319,6	6,45
21	30	24502521	352,9	335,45	6,89
22					
23					
24	30	24502524	400	383,05	9,07
25	30	24502525	416,4	398,95	9,97
26	30	24502526	432,3	414,8	12,06
27	30	24502527	448,2	430,7	12,88
28	30	24502528	464	446,55	13,83
30	30	24502530	495,8	478,35	14,32
32					
35					
38	30	24502538	622,9	605,45	21,50

### ROLLER 31

Z	D <sub>1</sub>	P. NUMBER	d <sub>e</sub>	d <sub>p</sub>	kg.
6	20	24503106	116,2	100,00	0,75
7	20	24503107	133,8	115,24	1,00
8	20	24503108	152,3	130,60	1,10
9	20	24503109	167,9	146,20	1,71
10	25	24503110	183,5	161,85	2,02
11	25	24503111	199,2	177,50	2,31
12	25	24503112	212,0	193,20	2,50
13	30	24503113	230,6	208,95	2,98
14	30	24503114	246,4	224,70	4,05
15	30	24503115	262,1	240,45	4,90
16	30	24503116	278,0	256,30	5,04
17					
18	30	24503118	309,6	287,95	6,90
19	30	24503119	325,5	303,80	6,85
20	30	24503120	341,3	319,60	8,06
21	30	24503121	357,1	335,45	8,80
22	30	24503122	373,0	351,35	9,90
23	30	24503123	388,9	367,20	10,06
24	30	24503124	404,7	383,05	11,25
25	30	24503125	419,7	398,95	12,30
26	30	24503126	436,5	414,80	14,11
27	30	24503127	452,4	430,70	15,46
28	30	24503128	468,2	446,55	16,80
30					
32	30	24503132	531,8	510,10	21,35
35	30	24503135	579,5	557,80	25,7
38	30	24503138	622,0	605,45	30,05

MATERIAL **FE / C45**

Ask for specific needs.



CAD drawings available on our site  
[www.chiaravalli.com](http://www.chiaravalli.com)

Quantity, availability and prices  
 on B2B Chiaravalli

**PLATEWHEELS P75 R 25**
**CHAIN**

Pitch	75	mm
Inner width	15	mm
Roller Ø	25	mm
Plate thickness B <sub>1</sub>	13,8	mm

**PLATEWHEELS P75 R 31**
**CHAIN**

Pitch	75	mm
Inner width	15	mm
Roller Ø	31	mm
Plate thickness B <sub>1</sub>	13,8	mm

**ROLLER 25**

Z	D <sub>1</sub>	P. NUMBER	d <sub>e</sub>	d <sub>p</sub>	kg.
8	30	24752508	213,4	195,98	3,20
9	30	24752509	236,8	219,3	4,00
10	30	24752510	260,2	242,77	5,00
11	30	24752511	283,7	266,25	5,43
12	30	24752512	307,3	289,8	7,00
13	30	24752513	330,9	313,42	7,56
14					
15	30	24752515	378,1	360,67	8,00
16	30	24752516	401,9	384,45	12,17
17					
20					
21					
25	30	24752525	615,9	598,42	29,25

**ROLLER 31**

Z	D <sub>1</sub>	P. NUMBER	d <sub>e</sub>	d <sub>p</sub>	kg.
8	30	24753108	217,6	195,98	3,50
9	30	24753109	241	219,3	3,80
10	30	24753110	264,4	242,77	4,50
11	30	24753111	287,9	266,25	5,57
12	30	24753112	311,5	289,8	6,70
13	30	24753113	334,1	313,42	7,80
14	30	24753114	358,7	337,05	9,12
15	30	24753115	382,3	360,67	10,42
16	30	24753116	406,1	384,45	11,98
17					
20					
21	30	24753121	524,8	503,17	20,62
25	30	24753125	620,1	598,42	27,00

**PLATEWHEELS P100 R 31**
**CHAIN**

Pitch	100	mm
Inner width	15	mm
Roller Ø	31	mm
Plate thickness B <sub>1</sub>	13,8	mm

**PLATEWHEELS P100 R 40**
**CHAIN**

Pitch	100	mm
Inner width	22	mm
Roller Ø	40	mm
Plate thickness B <sub>1</sub>	20	mm

**ROLLER 31**

Z	D <sub>1</sub>	P. NUMBER	d <sub>e</sub>	d <sub>p</sub>	kg.
8	30	24993108	282,9	261,31	4,92
9	30	24993109	314,1	292,4	6,03
10	30	24993110	345,4	323,61	8,00
11	30	24993111	376,7	354,95	9,04
12	30	24993112	408,1	386,4	10,75
13	30	24993113	439,6	417,9	16,00
14	30	24993114	471,1	449,4	17,00
15	30	24993115	502,6	480,9	19,00
16	30	24993116	534,3	512,6	21,80
17	30	24993117	565,8	544,1	24,77
18	30	24993118	597,6	575,9	26,43
19					
20					

**ROLLER 40**

Z	D <sub>1</sub>	P. NUMBER	d <sub>e</sub>	d <sub>p</sub>	kg.
8	30	24994008	282,9	261,31	7,14
9	30	24994009	314,1	292,4	10,03
10	30	24994010	345,4	323,61	11,95
11	30	24994011	376,7	354,95	15,02
12	30	24994012	408,1	386,4	17,27
13					
14	30	24994014	471,1	449,4	24,60
15					
16	30	24994016	534,3	512,6	27,99
17					
18					
19					
20	30	24994020	663	639,2	42,62

MATERIAL **FE / C45**

Ask for specific needs.

CAD drawings available on our site  
[www.chiaravalli.com](http://www.chiaravalli.com)

Quantity, availability and prices  
 on B2B Chiaravalli

