

Approved Performance from Rexnord

Roller chains | European type



Roller chains - European type

Approved performance from Rexnord.

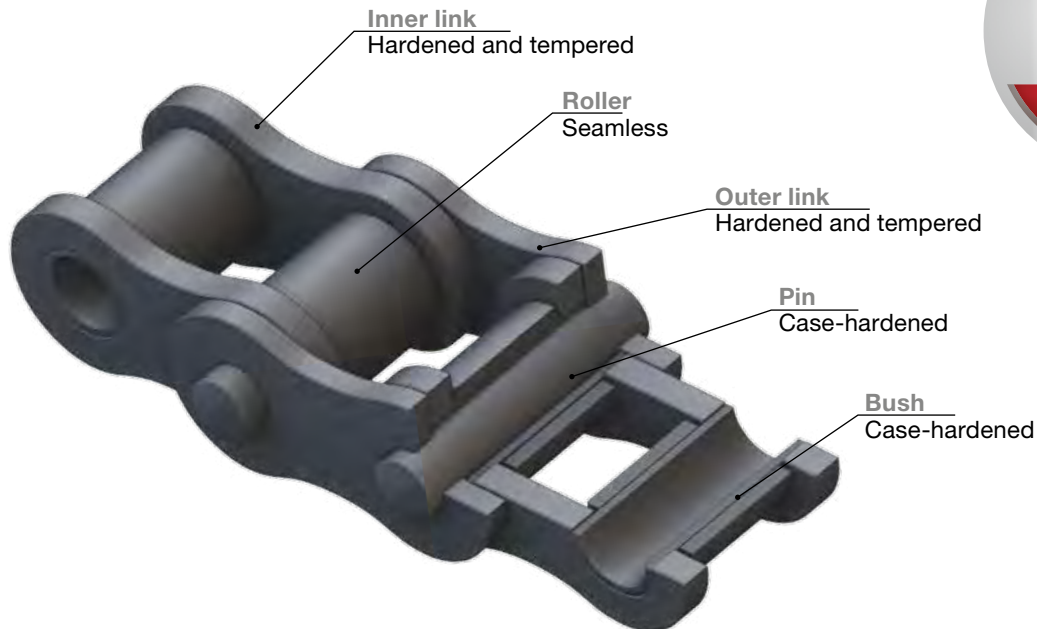

APPLICATIONS

- Light and medium duty
- Agricultural machinery, wood processing
- Textile industry

CHARACTERISTICS

- Established brand name
- Fulfils ISO quality requirements
- Rexnord guarantees the achievement of performance requirements

ADVANTAGES

- Good cost-benefit ratio
- Good availability
- Robust quality

LUBRICATION

- Contains no heavy metals
- Fulfils REACH requirements

Roller chains - European type

Approved performance from Rexnord.

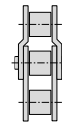

Simplex roller chains



Proven performance

- Fulfills ISO quality requirements
- Rexnord guarantees the achievement of performance requirements
- Optimum choice for light and medium duty



Purchasing policy

- Suppliers must comply with local environmental laws
- Suppliers must comply with Rexnord's ethical policy and internal guidelines
- Suppliers must take local environmental policy into account



Economical

- Good cost-benefit ratio
- Good availability



Simplex roller chains, DIN 8187 ISO 606

| Chain No. | Pitch p | | Inner width | Roller Ø | Pin Ø | Inner link width | Link plate height | Mean dimension | Pin length | Length of conn link pin | Bearing area | Required min. breaking strength DIN/ISO | Weight | Individual components | | | | | | | | | | | | |
|-----------|----------|--------|-------------|----------|-------|------------------|-------------------|----------------|------------|-------------------------|--------------|---|--------|-----------------------|--------------------|---------------------|--------------------|---|---|---------------------|---------------------|---|----------------|-----|---|----|
| | inch | mm | | | | | | | | | | | | b ₁ min. | d ₁ max | d ₂ max. | b ₂ max | g | e | a ₁ max. | a ₃ max. | A | F _B | ≈ q | A | AK |
| | 04 B - 1 | 0.236 | 6.000 | 7.11 | 7.91 | 4.80 | 4.10 | 3.30 | 3.18 | 5.01 | 5.81 | 6.40 | 6 940 | 0.250 | | | | | | | | x | x | x | | |
| 05 B - 1 | 0.315 | 8.000 | 11.21 | 12.61 | 7.46 | 4.77 | 5.08 | 4.78 | 7.80 | 9.04 | 10.13 | 15 650 | 0.630 | | | | | | | | x | x | x | | | |
| 06 B - 1 | 0.375 | 9.525 | 15.45 | 17.53 | 11.17 | 8.53 | 7.92 | 7.92 | 10.41 | 12.06 | 14.38 | 27 800 | 1.220 | | | | | | | | x | x | x | | | |
| 08 B - 1 | 0.500 | 12.700 | 19.18 | 21.58 | 13.84 | 11.30 | 10.16 | 9.52 | 13.01 | 15.08 | 18.11 | 43 600 | 2.000 | | | | | | | | x | x | x | | | |
| 10 B - 1 | 0.625 | 15.875 | 24.10 | 26.80 | 17.75 | 13.28 | 11.91 | 12.70 | 15.64 | 18.09 | 22.78 | 62 600 | 2.870 | | | | | | | | x | x | x | | | |
| 12 B - 1 | 0.750 | 19.050 | 31.10 | 35.20 | 22.60 | 15.62 | 15.87 | 15.88 | 20.82 | 24.13 | 29.29 | 111 200 | 5.050 | | | | | | | | | x | x | | | |
| 16 B - 1 | 1.000 | 25.400 | 38.14 | 42.04 | 27.45 | 25.45 | 19.05 | 19.05 | 26.03 | 30.16 | 35.76 | 174 000 | 7.860 | | | | | | | | | x | x | | | |
| 20 B - 1 | 1.250 | 31.750 | 48.13 | 52.33 | 35.45 | 29.01 | 22.22 | 25.40 | 31.24 | 36.19 | 45.44 | 250 000 | 11.200 | | | | | | | | | | x | x | | |
| 24 B - 1 | 1.500 | 38.100 | 51.57 | 56.97 | 37.18 | 37.92 | 25.40 | 25.40 | 36.44 | 42.22 | 48.87 | 340 000 | 14.660 | | | | | | | | | | x | x | | |
| 28 B - 1 | 1.750 | 44.450 | 62.41 | 65.21 | 45.21 | 46.50 | 28.57 | 31.75 | 41.65 | 48.26 | 58.55 | 446 000 | 18.640 | | | | | | | | | | | x | | |
| 32 B - 1 | 2.000 | 50.800 | 75.95 | 82.15 | 54.88 | 45.50 | 39.67 | 38.10 | 52.07 | 60.32 | 71.55 | 649 000 | 31.630 | | | | | | | | | | | x | | |

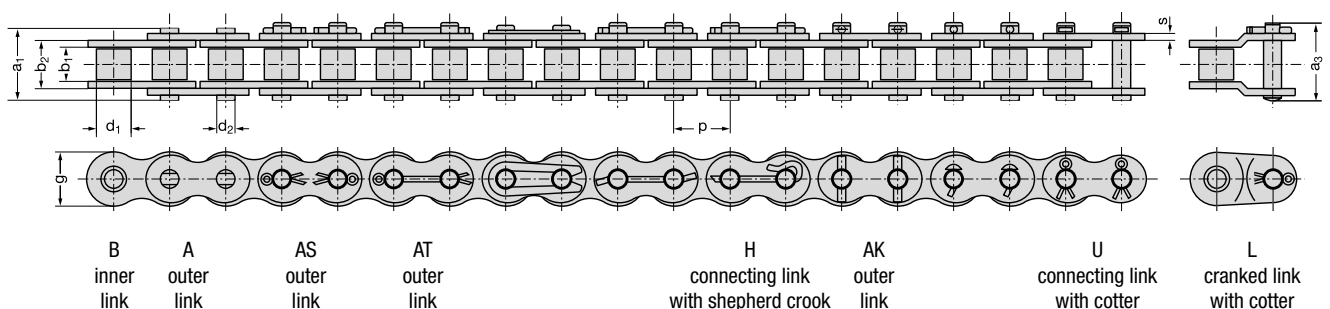

Roller chains - European type

Approved performance from Rexnord.

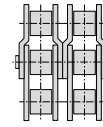

Duplex roller chains



Proven performance

- Fulfills ISO quality requirements
- Rexnord guarantees the achievement of performance requirements
- Optimum choice for light and medium duty



Purchasing policy

- Suppliers must comply with local environmental laws
- Suppliers must comply with Rexnord's ethical policy and internal guidelines
- Suppliers must take local environmental policy into account



Economical

- Good cost-benefit ratio
- Good availability

Duplex roller chains, DIN 8187 ISO 606

| Chain No. | Pitch p | | Inner width | | Roller Ø | Pin Ø | Inner link width | | Link plate height | Mean dimension | Pin length | Length of conn link pin | Bearing area | Required min. breaking strength DIN/ISO | Weight | Individual components | | | | | |
|-----------|---------|-------|---------------------|--------------------|---------------------|--------------------|------------------|-------|---------------------|---------------------|------------|-------------------------|-----------------|---|--------|-----------------------|---|---|---|---|--|
| | inch | mm | b ₁ min. | d ₁ max | d ₂ max. | b ₂ max | g | e | a ₁ max. | a ₃ max. | A | F _B | q | A | B | C | E | L | S | | |
| | | | mm | mm | mm | mm | mm | mm | mm | mm | mm | mm | cm ² | N | kg/m | | | | | | |
| 06 B - 2 | 0.375 | 9.52 | 5.72 | 6.35 | 3.28 | 8.53 | 8.2 | 10.24 | 23.8 | 27.1 | 0.56 | 16 900 | 0.78 | | | | x | x | x | | |
| 08 B - 2 | 0.5 | 12.70 | 7.75 | 8.51 | 4.45 | 11.3 | 11.6 | 13.92 | 30.6 | 34.9 | 1.01 | 31 100 | 1.4 | | | | x | x | x | | |
| 10 B - 2 | 0.625 | 15.87 | 9.65 | 10.16 | 5.08 | 13.28 | 14.6 | 16.59 | 35.5 | 40.3 | 1.34 | 44 500 | 1.8 | | | | x | x | x | | |
| 12 B - 2 | 0.75 | 19.05 | 11.68 | 12.07 | 5.72 | 15.62 | 15.9 | 19.46 | 41.7 | 46.8 | 1.79 | 57 800 | 2.3 | | | | x | x | x | | |
| 16 B - 2 | 1 | 25.40 | 17.02 | 15.88 | 8.28 | 25.4 | 20.5 | 31.88 | 67.4 | 73.4 | 4.21 | 106 000 | 5.3 | | | | x | x | x | x | |
| 20 B - 2 | 1.25 | 31.75 | 19.56 | 19.05 | 10.19 | 29 | 25.7 | 36.45 | 76.9 | 83.6 | 5.91 | 170 000 | 7.25 | | | | | | x | x | |
| 24 B - 2 | 1.5 | 38.10 | 25.4 | 25.4 | 14.63 | 37.9 | 33 | 48.36 | 102.2 | 112.7 | 11.09 | 280 000 | 13.75 | | | | | | x | x | |
| 28 B - 2 | 1.75 | 44.45 | 30.99 | 27.94 | 15.9 | 46.5 | 37 | 59.56 | 122.8 | 132.7 | 14.79 | 360 000 | 17.3 | | | | | | x | x | |
| 32 B - 2 | 2 | 50.80 | 30.99 | 29.21 | 17.81 | 45.5 | 41.2 | 58.55 | 123.6 | 132.4 | 16.21 | 450 000 | 18.8 | | | | | | x | x | |

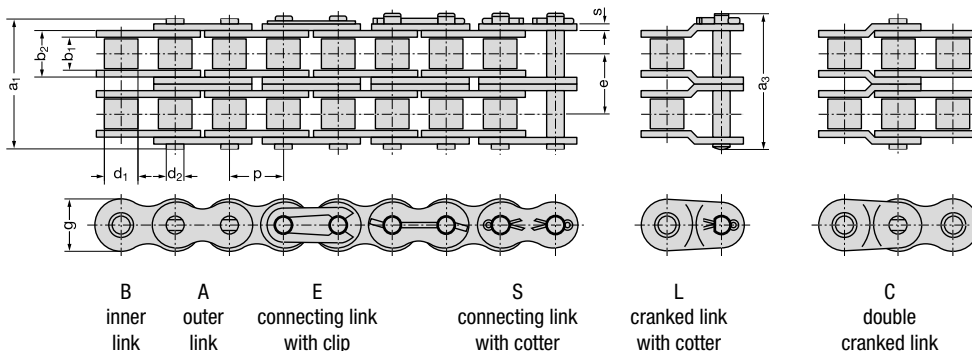

Overview Rexnord roller chains

Roller Chains

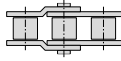

REXNORD

RexPro
RexPro lubrication
improved wear resistance
high fatigue resistance

- Outstanding protection against corrosion and wear
- Unique protection against chain joint stiffness
- Extremely eco-friendly

REXNORD

RexAthletic
good loading capacity
extended lubrication intervals

- Durable and low-maintenance
- Longer servicing intervals
- High loading capacity

REXNORD

RexCarbon
no lubrication
low noise

- Maintenance-free
- Low noise
- Eco-friendly

REXNORD

RexPlus
excellent corrosion resistance
high reliability

- Excellent resistance to rust and acids
- Highly reliable
- Fulfills hygiene requirements
- NSF H1 certification

REXNORD

RexPlusCarbon
no lubrication
excellent corrosion resistance

- Combination of RexPlus and RexCarbon
- Excellent resistance to rust and acids
- Maintenance-free
- NSF H1 certification

REXNORD

RexHiPro
good corrosion resistance
excellent loading capacity

- Outstanding corrosion resistance
- Long service life
- High loading capacity

Link-Belt
a brand of
REXNORD

- The optimum choice for light and medium duty
- Good cost-benefit ratio
- High availability

REXNORD

RexProX
RexPro lubrication
improved wear resistance
high fatigue resistance

- Extremely high loading capacity
- Long service life
- Outstanding protection against corrosion and wear

Flyer Chains

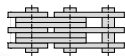

REXNORD

RexPro
RexPro lubrication
improved wear resistance
high fatigue resistance

- Outstanding protection against corrosion and wear
- Unique protection against chain joint stiffness
- Extremely eco-friendly

REXNORD

RexHiPro
good corrosion resistance
excellent loading capacity

- Outstanding corrosion resistance
- Long service life
- High loading capacity

REXNORD

RexDura
improved wear resistance
lubrication stay in chain hinge

- Durable and low-maintenance
- Longer servicing intervals
- High loading capacity
- Extreme wear resistance for double-length service life

REXDL
a brand of
REXNORD

- The optimum choice for light and medium duty
- Good cost-benefit ratio
- Good availability



Approved Performance from Rexnord

Roller chains | American type



Roller chains - American type

Approved performance from Rexnord.

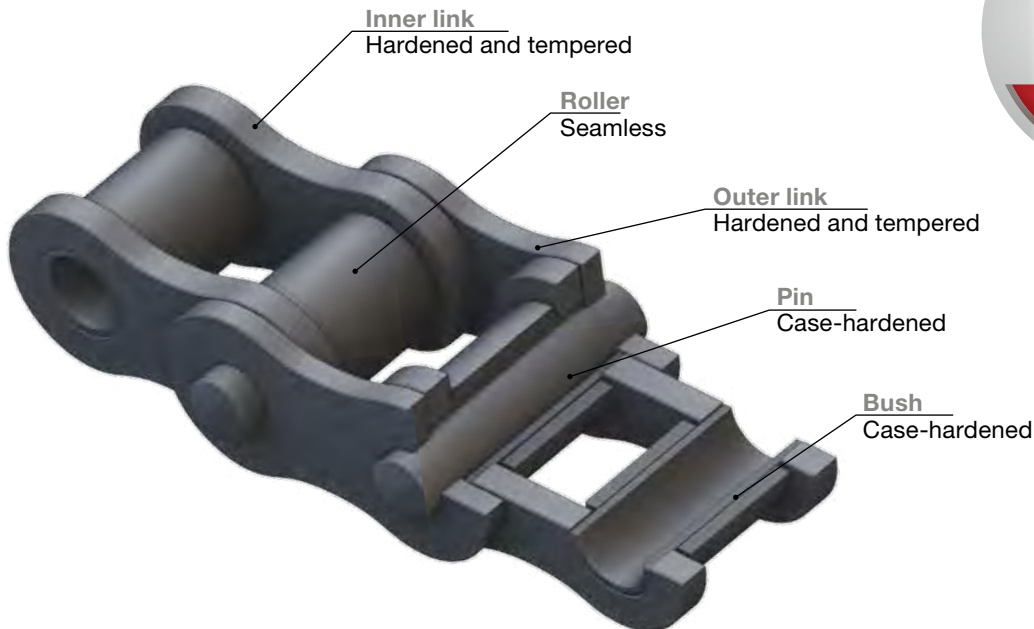

APPLICATIONS

- Light and medium duty
- Agricultural machinery, wood processing
- Textile industry

CHARACTERISTICS

- Established brand name
- Fulfil ISO quality requirements
- Rexnord guarantees achievement of performance requirements

ADVANTAGES

- Good cost-benefit ratio
- Good availability
- Robust quality

LUBRICATION

- Contains no heavy metals
- Fulfil REACH requirements

Roller chains - American type

Approved performance from Rexnord.

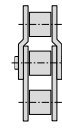

Simplex roller chains



Proven performance

- Fulfills ISO quality requirements
- Rexnord guarantees the achievement of performance requirements
- Optimum choice for light and medium duty



Purchasing policy

- Suppliers must comply with local environmental laws
- Suppliers must comply with Rexnord's ethical policy and internal guidelines
- Suppliers must take local environmental policy into account



Economical

- Good cost-benefit ratio
- Good availability



Simplex roller chains, ANSI

| Chain No. | Pitch p | | Inner width | | Roller Ø | Pin Ø | Inner link width | Link plate height | Mean dimension | Pin length | Length of conn link pin | Bearing area | Required min. breaking strength DIN/ISO | Rexnord mean breaking load | Weight | Individual components | | | | | | | | | |
|-----------|---------|-------|---------------------|---------------------|---------------------|---------------------|------------------|-------------------|---------------------|---------------------|-------------------------|-----------------|---|----------------------------|--------|-----------------------|----|----|---|---|---|---|---|---|--|
| | inch | mm | b ₁ min. | d ₁ max. | d ₂ max. | b ₂ max. | g | e | a ₁ max. | a ₃ max. | A | F _B | F _B | ≈ q | A | AK | AS | AT | B | C | E | L | S | U | |
| | | | mm | mm | mm | mm | mm | mm | mm | mm | mm | cm ² | N | N | kg/m | | | | | | | | | | |
| 40-1 | 0.5 | 12.70 | 7.85 | 7.95 | 3.96 | 11.15 | 11.6 | - | 16.3 | 21.7 | 0.44 | 13 900 | 20 000 | 0.62 | | | | | | x | x | x | | | |
| 50-1 | 0.625 | 15.87 | 9.4 | 10.16 | 5.08 | 13.8 | 14.6 | - | 20.3 | 25.9 | 0.7 | 21 800 | 30 000 | 1.01 | | | | | | x | x | x | | | |
| 60-1 | 0.75 | 19.05 | 12.57 | 11.91 | 5.94 | 17.7 | 17.7 | - | 25.7 | 31.5 | 1.05 | 31 300 | 40 000 | 1.48 | | | | | | x | x | x | x | | |
| 80-1 | 1 | 25.40 | 15.75 | 15.88 | 7.92 | 22.5 | 23.5 | - | 33 | 38.9 | 1.78 | 55 600 | 65 000 | 2.6 | | | | | | x | x | x | x | | |
| 100-1 | 1.25 | 31.75 | 18.9 | 19.05 | 9.53 | 27.4 | 29.2 | - | 39.4 | 44.9 | 2.61 | 87 000 | 105 000 | 3.76 | | | | | | | | x | x | | |
| 120-1 | 1.5 | 38.10 | 25.22 | 22.23 | 11.1 | 35.3 | 34.4 | - | 49.8 | 56.1 | 3.92 | 125 000 | 145 000 | 5.5 | | | | | | | | x | x | | |
| 140-1 | 1.75 | 44.45 | 25.22 | 25.4 | 12.7 | 37 | 40.8 | - | 53.4 | 59.3 | 4.7 | 170 000 | 220 000 | 7.2 | | | | | | | | x | | x | |
| 160-1 | 2 | 50.80 | 31.55 | 28.58 | 14.27 | 45 | 47.8 | - | 63.6 | 68.9 | 6.42 | 223 000 | 260 000 | 10.3 | | | | | | | | x | | x | |

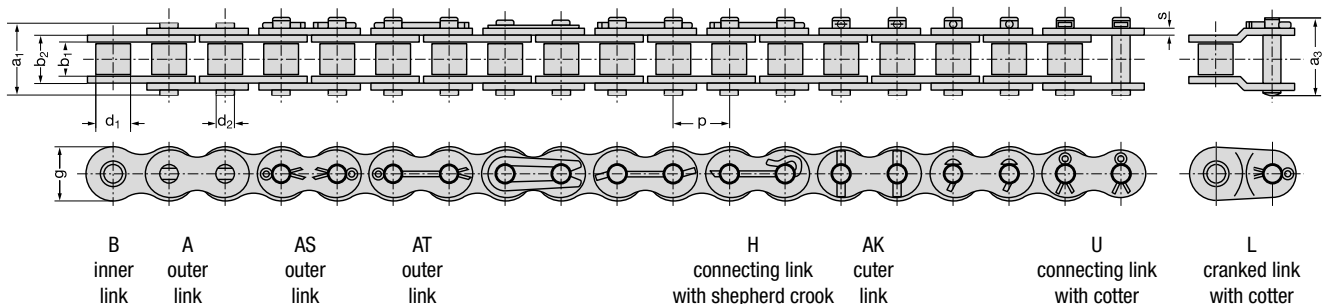

Roller chains - American type

Approved performance from Rexnord.

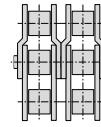

Duplex roller chains



Proven performance

- Fulfills ISO quality requirements
- Rexnord guarantees the achievement of performance requirements
- Optimum choice for light and medium duty



Purchasing policy

- Suppliers must comply with local environmental laws
- Suppliers must comply with Rexnord's ethical policy and internal guidelines
- Suppliers must take local environmental policy into account



Economical

- Good cost-benefit ratio
- Good availability

Duplex roller chains, ANSI

| Chain No. | Pitch p | | Inner width | | Roller \varnothing | Pin \varnothing | Inner link width | Link plate height | Mean dimension | Pin length | Length of conn link pin | Beating area | Required min. breaking strength DIN/ISO | Rexnord mean breaking load | Weight | Individual components | | | | | | | | | |
|-----------|---------|--------|-------------|------------|----------------------|-------------------|------------------|-------------------|----------------|------------|-------------------------|-----------------|---|----------------------------|--------|-----------------------|----|----|---|---|---|---|---|---|--|
| | inch | mm | b_1 min. | d_1 max. | d_2 max. | b_2 max. | g | e | a_1 max. | a_3 max. | A | F_B | F_B | $\approx q$ | A | AK | AS | AT | B | C | E | L | S | U | |
| | | | mm | mm | mm | mm | mm | mm | mm | mm | mm | cm ² | N | N | kg/m | | | | | | | | | | |
| 40 - 2 | 0.5 | 12.7 | 7.85 | 7.95 | 3.96 | 11.15 | 11.6 | 14.38 | 30.7 | 36.2 | 0.88 | 27 800 | 40 000 | 1.22 | | | | | | | x | | | | |
| 50 - 2 | 0.625 | 15.875 | 9.4 | 10.16 | 5.08 | 13.8 | 14.6 | 18.11 | 38.5 | 44.0 | 1.4 | 43 600 | 60 000 | 2 | | | | | | x | x | | | | |
| 60 - 2 | 0.75 | 19.05 | 12.57 | 11.91 | 5.94 | 17.7 | 17.7 | 22.78 | 48.5 | 54.4 | 2.1 | 62 600 | 80 000 | 2.95 | | | | | | | x | | x | | |
| 80 - 2 | 1 | 25.4 | 15.75 | 15.88 | 7.92 | 22.5 | 23.5 | 29.29 | 62.4 | 68.1 | 3.56 | 111 200 | 150 000 | 5.2 | | | | | | | | | x | | |
| 100 - 2 | 1.25 | 31.75 | 18.9 | 19.05 | 9.53 | 27.4 | 29.2 | 35.76 | 75.3 | 87.8 | 5.22 | 174 000 | 220 000 | 7.6 | | | | | | | | | x | | |
| 120 - 2 | 1.5 | 38.1 | 25.22 | 22.23 | 11.1 | 35.3 | 34.4 | 45.44 | 95.3 | 101.6 | 7.84 | 250 000 | 290 000 | 10.8 | | | | | | | | | x | | |
| 140 - 2 | 1.75 | 44.45 | 25.22 | 25.4 | 12.7 | 37 | 40.8 | 48.87 | 103.3 | 109.6 | 9.4 | 340 000 | 440 000 | 14.2 | x | | | | | | | | | x | |
| 160 - 2 | 2 | 50.8 | 31.55 | 28.58 | 14.27 | 45 | 47.8 | 58.55 | 122.1 | 130.1 | 12.84 | 446 000 | 490 000 | 19.5 | x | | | | | | | | | x | |

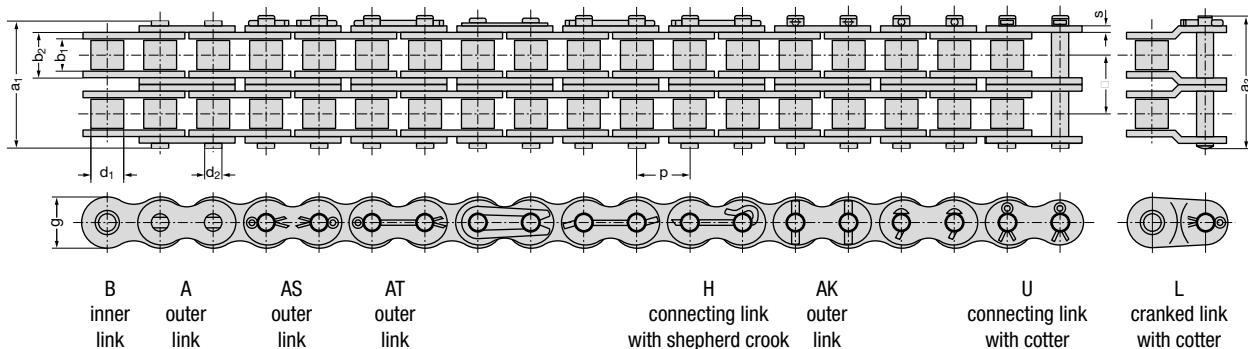

Roller chains - American type

Approved performance from Rexnord.

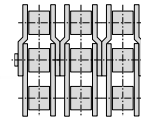

Triplex roller chains



Proven performance

- Fulfills ISO quality requirements
- Rexnord guarantees the achievement of performance requirements
- Optimum choice for light and medium duty



Purchasing policy

- Suppliers must comply with local environmental laws
- Suppliers must comply with Rexnord's ethical policy and internal guidelines
- Suppliers must take local environmental policy into account



Economical

- Good cost-benefit ratio
- Good availability



Triplex roller chains, ANSI

| Chain No. | Pitch p | | Inner width | | Roller Ø | Pin Ø | Inner link width | Link plate height | Mean dimension | Pin length | Length of conn link pin | Bearing area | Required min. breaking strength DIN/ISO | Rexnord mean breaking load | Weight | Individual components | | | | | | | | | |
|-----------|---------|-------|---------------------|---------------------|---------------------|---------------------|------------------|-------------------|---------------------|---------------------|-------------------------|-----------------|--|----------------------------|--------|-----------------------|----|----|---|---|---|---|---|---|--|
| | inch | mm | b ₁ min. | d ₁ max. | d ₂ max. | b ₂ max. | g | e | a ₁ max. | a ₃ max. | A | F _B | F _B | ≈ q | A | AK | AS | AT | B | C | E | L | S | U | |
| | | | mm | mm | mm | mm | mm | mm | mm | mm | mm | cm ² | N | N | kg/m | | | | | | | | | | |
| 40 - 3 | 0.5 | 12.70 | 7.85 | 7.95 | 3.96 | 11.15 | 11.6 | 14.48 | 45.1 | 50.6 | 1.32 | 41 700 | 60 000 | 1.83 | | | | | | | | x | x | | |
| 50 - 3 | 0.625 | 15.87 | 9.4 | 10.16 | 5.08 | 13.8 | 14.6 | 18.11 | 56.7 | 62.0 | 2.1 | 65 400 | 90 000 | 2.97 | | | | | | | | x | x | | |
| 60 - 3 | 0.75 | 19.05 | 12.57 | 11.91 | 5.94 | 17.7 | 17.7 | 22.78 | 71.4 | 77.2 | 3.15 | 93 900 | 120 000 | 4.35 | | | | | | | | x | x | x | |
| 80 - 3 | 1 | 25.40 | 15.75 | 15.88 | 7.92 | 22.5 | 23.5 | 29.29 | 91.7 | 97.3 | 5.35 | 166 800 | 220 000 | 7.9 | | | | | | | | x | x | | |
| 100 - 3 | 1.25 | 31.75 | 18.9 | 19.05 | 9.53 | 27.4 | 29.2 | 35.76 | 111.1 | 117.2 | 7.83 | 261 000 | 300 000 | 11.4 | | | | | | | | x | x | | |
| 120 - 3 | 1.5 | 38.10 | 25.22 | 22.23 | 11.1 | 35.3 | 34.4 | 45.44 | 140.7 | 148.3 | 11.76 | 375 000 | 450 000 | 15.8 | | | | | | | | x | x | | |
| 140 - 3 | 1.75 | 44.45 | 25.22 | 25.4 | 12.7 | 37 | 40.8 | 48.87 | 151.2 | 158.5 | 14.1 | 510 000 | 660 000 | 21.5 | | x | | | | | | x | | x | |
| 160 - 3 | 2 | 50.80 | 31.55 | 28.58 | 14.27 | 45 | 47.8 | 58.55 | 180.7 | 188.7 | 19.26 | 669 000 | 790 000 | 26.3 | | x | | | | | | x | | x | |

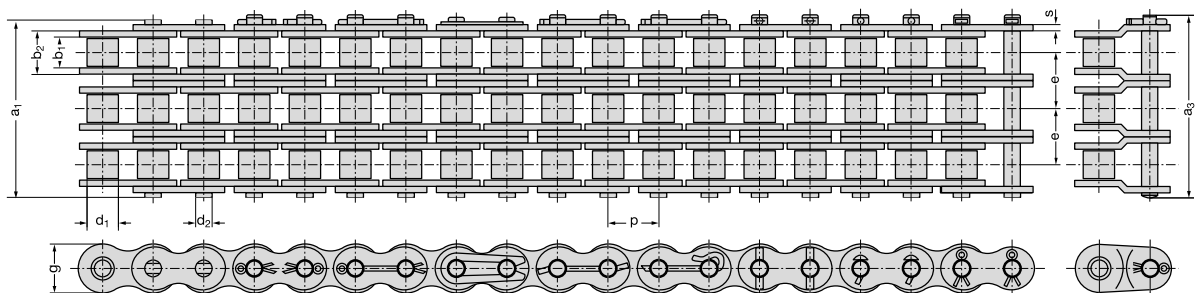

B inner link A outer link AS outer link AT outer link H connecting link with shepherd crook AK outer link U connecting link with cotter L cranked link with cotter

Overview Rexnord roller chains

Roller Chains

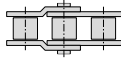

REXNORD

RexPro
RexPro lubrication
improved wear resistance
high fatigue resistance

- Outstanding protection against corrosion and wear
- Unique protection against chain joint stiffness
- Extremely eco-friendly

REXNORD

RexAthletic
good loading capacity
extended lubrication intervals

- Durable and low-maintenance
- Longer servicing intervals
- High loading capacity

REXNORD

RexCarbon
no lubrication
low noise

- Maintenance-free
- Low noise
- Eco-friendly

REXNORD

RexPlus
excellent corrosion resistance
high reliability

- Excellent resistance to rust and acids
- Highly reliable
- Fulfills hygiene requirements
- NSF H1 certification

REXNORD

RexPlusCarbon
no lubrication
excellent corrosion resistance

- Combination of RexPlus and RexCarbon
- Excellent resistance to rust and acids
- Maintenance-free
- NSF H1 certification

REXNORD

RexHiPro
good corrosion resistance
excellent loading capacity

- Outstanding corrosion resistance
- Long service life
- High loading capacity

Link-Belt
a brand of REXNORD

- The optimum choice for light and medium duty
- Good cost-benefit ratio
- High availability

REXNORD

RexProX
RexPro lubrication
improved wear resistance
high fatigue resistance

- Extremely high loading capacity
- Long service life
- Outstanding protection against corrosion and wear

Flyer Chains

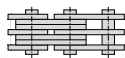

REXNORD

RexPro
RexPro lubrication
improved wear resistance
high fatigue resistance

- Outstanding protection against corrosion and wear
- Unique protection against chain joint stiffness
- Extremely eco-friendly

REXNORD

RexHiPro
good corrosion resistance
excellent loading capacity

- Outstanding corrosion resistance
- Long service life
- High loading capacity

REXNORD

RexDura
improved wear resistance
lubrication stay in chain hinge

- Durable and low-maintenance
- Longer servicing intervals
- High loading capacity
- Extreme wear resistance for double-length service life

REXDL
a brand of REXNORD

- The optimum choice for light and medium duty
- Good cost-benefit ratio
- Good availability



Approved Performance from Rexnord

Roller chains H Series | American type

Link-Belt®

a brand of
REXNORD



Roller chains H Series - American type

Approved performance from Rexnord.

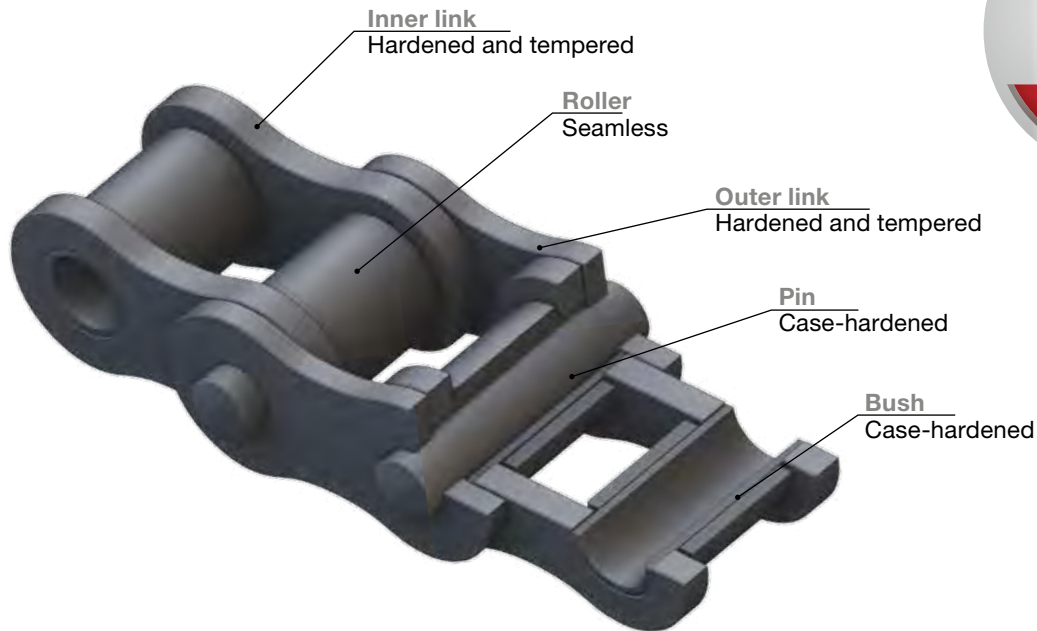

APPLICATIONS

- Light and medium duty
- Agricultural machinery, wood processing
- Textile industry

CHARACTERISTICS

- Established brand name
- Fulfils ISO quality requirements
- Rexnord guarantees achievement of performance requirements

ADVANTAGES

- Good cost-benefit ratio
- Good availability
- Robust quality

LUBRICATION

- Contains no heavy metals
- Fulfils REACH requirements

Roller chains H Series - American type

Approved performance from Rexnord.

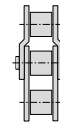

Simplex roller chains



Proven performance

- Fulfills ISO quality requirements
- Rexnord guarantees the achievement of performance requirements
- Optimum choice for light and medium duty



Purchasing policy

- Suppliers must comply with local environmental laws
- Suppliers must comply with Rexnord's ethical policy and internal guidelines
- Suppliers must take local environmental policy into account



Economical

- Good cost-benefit ratio
- Good availability



Simplex roller chains H-Serie, ANSI

| Chain No. | Pitch p | | Inner width | | Roller Ø | Pin Ø | Inner link width | | Plate link thickness | Link plate height | Mean dimension | Pin length | Length of conn link pin | Bearing area | Required min. breaking strength DIN/ISO | Weight | Individual components | | | | | | | |
|-----------|---------|-------|---------------------|--------------------|---------------------|--------------------|------------------|------|----------------------|---------------------|---------------------|------------|-------------------------|-----------------|---|--------|-----------------------|----|----|---|---|---|---|--|
| | inch | mm | b ₁ min. | d ₁ max | d ₂ max. | b ₂ max | s | g | e | a ₁ max. | a ₃ max. | A | F _B | ≈ q | A | B | AK | AS | AT | H | L | S | U | |
| | | | mm | mm | mm | mm | mm | mm | mm | mm | mm | mm | mm | cm ² | N | kg/m | | | | | | | | |
| 60 H - 1 | 0.75 | 19.05 | 12.57 | 11.91 | 5.94 | 19.35 | 3.05 | 17.7 | - | 28.8 | 32 | 1.15 | 31 300 | 1.97 | | | | | | | | | x | |
| 80 H - 1 | 1 | 25.40 | 15.75 | 15.88 | 7.92 | 24.3 | 4 | 23.5 | - | 35.9 | 41 | 1.94 | 55 600 | 3.2 | | | | | | | | | x | |
| 100 H - 1 | 1.25 | 31.75 | 18.9 | 19.05 | 9.53 | 29 | 4.7 | 29.2 | - | 42.8 | 48.2 | 2.76 | 87 000 | 4.4 | | | | | | | | | x | |
| 120 H - 1 | 1.5 | 38.10 | 25.22 | 22.23 | 11.1 | 37 | 5.5 | 34.4 | - | 53 | 59 | 4.12 | 125 000 | 6.4 | | | | | | | | | x | |
| 140 H - 1 | 1.75 | 44.45 | 25.22 | 25.4 | 12.7 | 38.7 | 6.3 | 40.8 | - | 56.6 | 62.6 | 4.91 | 170 000 | 8.3 | | | | | x | | | x | x | |
| 160 H - 1 | 2 | 50.80 | 31.55 | 28.58 | 14.27 | 46.9 | 7 | 47.8 | - | 67.2 | 72.3 | 6.69 | 223 000 | 11.5 | | | | | x | | | x | x | |

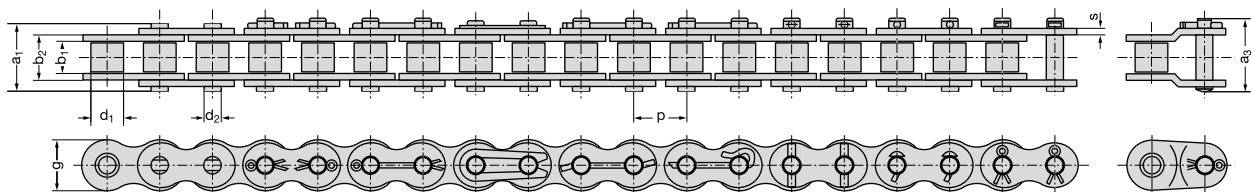

B inner link A outer link AS outer link AT outer link H connecting link with shepherd crook AK outer link U connecting link with cotter L cranked link with cotter

Roller chains H Series - American type

Approved performance from Rexnord.

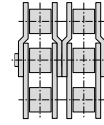

Duplex roller chains



Proven performance

- Fulfills ISO quality requirements
- Rexnord guarantees the achievement of performance requirements
- Optimum choice for light and medium duty



Purchasing policy

- Suppliers must comply with local environmental laws
- Suppliers must comply with Rexnord's ethical policy and internal guidelines
- Suppliers must take local environmental policy into account



Economical

- Good cost-benefit ratio
- Good availability

Duplex roller chains, ANSI | H-Serie

| Chain No. | Pitch p | | Inner width | | Roller Ø | Pin Ø | Inner link width | | Plate link thickness | Link plate height | Mean dimension | Pin length | Locking Pin length | Bearing area | Required min. breaking strength DIN/ISO | Weight | Individual components | | | | | | | |
|-----------|---------|-------|---------------------|---------------------|---------------------|---------------------|------------------|------|----------------------|---------------------|---------------------|------------|--------------------|-----------------|---|--------|-----------------------|----|----|---|---|---|---|---|
| | inch | mm | b ₁ min. | d ₁ max. | d ₂ max. | b ₂ max. | s | g | e | a ₁ max. | a ₃ max. | A | F _B | z q | A | B | AK | AS | AT | H | L | S | U | |
| | | | mm | mm | mm | mm | mm | mm | mm | mm | mm | mm | mm | cm ² | N | kg/m | | | | | | | | |
| 60 H - 2 | 0.75 | 19.05 | 12.57 | 11.91 | 5.94 | 19.35 | 3.05 | 17.7 | 26.1 | 54.9 | 58 | 2.3 | 62 600 | 3.95 | | | | | | | | | x | |
| 80 H - 2 | 1 | 25.4 | 15.75 | 15.88 | 7.92 | 24.3 | 4 | 23.5 | 32.6 | 68.6 | 73.7 | 3.88 | 112 200 | 6.3 | | | | | | | | | x | |
| 100 H - 2 | 1.25 | 31.75 | 18.9 | 19.05 | 9.53 | 29 | 4.7 | 29.2 | 39.12 | 82 | 97.8 | 5.52 | 174 000 | 9 | | | | | | | | | x | |
| 120 H - 2 | 1.5 | 38.1 | 25.22 | 22.23 | 11.1 | 37 | 5.5 | 34.4 | 48.91 | 101.8 | 109.5 | 8.36 | 250 000 | 12.6 | | | | | | | | | x | |
| 140 H - 2 | 1.75 | 44.45 | 25.22 | 25.4 | 12.7 | 38.7 | 6.3 | 40.8 | 52.2 | 108.7 | 116 | 9.82 | 340 000 | 16.2 | | | x | | | | | | x | x |
| 160 H - 2 | 2 | 50.8 | 31.55 | 28.58 | 14.27 | 46.9 | 7 | 47.8 | 61.89 | 128.6 | 136.8 | 13.4 | 446 000 | 22 | | | x | | | | | | x | x |

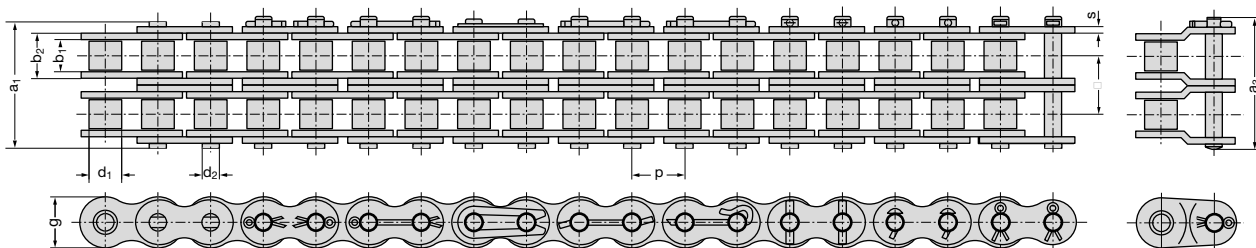

B inner link A outer link AS outer link AT outer link H connecting link with shepherd crook AK outer link U connecting link with cotter L cranked link with cotter



Overview Rexnord roller chains

Roller Chains

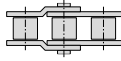

REXNORD
RexPro
RexPro lubrication
improved wear resistance
high fatigue resistance

- Outstanding protection against corrosion and wear
- Unique protection against chain joint stiffness
- Extremely eco-friendly

REXNORD
RexAthletic
good loading capacity
extended lubrication intervals

- Durable and low-maintenance
- Longer servicing intervals
- High loading capacity

REXNORD
RexCarbon
no lubrication
low noise

- Maintenance-free
- Low noise
- Eco-friendly

REXNORD
RexPlus
excellent corrosion resistance
high reliability

- Excellent resistance to rust and acids
- Highly reliable
- Fulfills hygiene requirements
- NSF H1 certification

REXNORD
RexPlusCarbon
no lubrication
excellent corrosion resistance

- Combination of RexPlus and RexCarbon
- Excellent resistance to rust and acids
- Maintenance-free
- NSF H1 certification

REXNORD
RexHiPro
good corrosion resistance
excellent loading capacity

- Outstanding corrosion resistance
- Long service life
- High loading capacity

Link-Belt
a brand of
REXNORD

- The optimum choice for light and medium duty
- Good cost-benefit ratio
- High availability

REXNORD
RexProX
RexPro lubrication
improved wear resistance
high fatigue resistance

- Extremely high loading capacity
- Long service life
- Outstanding protection against corrosion and wear

Flyer Chains

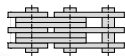

REXNORD
RexPro
RexPro lubrication
improved wear resistance
high fatigue resistance

- Outstanding protection against corrosion and wear
- Unique protection against chain joint stiffness
- Extremely eco-friendly

REXNORD
RexHiPro
good corrosion resistance
excellent loading capacity

- Outstanding corrosion resistance
- Long service life
- High loading capacity

REXNORD
RexDura
improved wear resistance
lubrication stay in chain hinge

- Durable and low-maintenance
- Longer servicing intervals
- High loading capacity
- Extreme wear resistance for double-length service life

REXDL
a brand of
REXNORD

- The optimum choice for light and medium duty
- Good cost-benefit ratio
- Good availability



Approved Performance from Rexnord

Roller chain | European type | Rust free



Rust free roller chains - European type

Approved performance from Rexnord.

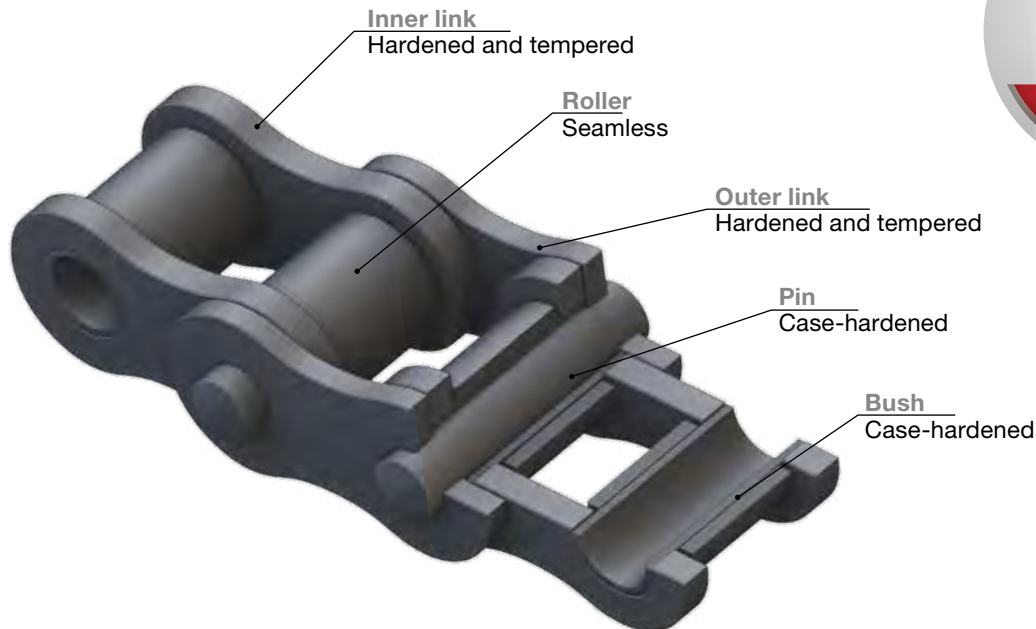

APPLICATIONS

- Light and medium duty
- Agricultural machinery, wood processing
- Textile industry

CHARACTERISTICS

- Established brand name
- Fulfils ISO quality requirements
- Rexnord guarantees achievement of performance requirements

ADVANTAGES

- Good cost-benefit ratio
- Good availability
- Robust quality

LUBRICATION

- Contains no heavy metals
- Fulfils REACH requirements

Rust-free Roller chains - European type

Approved performance from Rexnord.

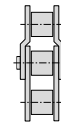

Simplex roller chains



Proven performance

- Fulfills ISO quality requirements
- Rexnord guarantees the achievement of performance requirements
- Optimum choice for light and medium duty



Purchasing policy

- Suppliers must comply with local environmental laws
- Suppliers must comply with Rexnord's ethical policy and internal guidelines
- Suppliers must take local environmental policy into account



Economical

- Good cost-benefit ratio
- Good availability



Simplex roller chains, ISO, rostfrei

| Chain No. | Pitch p | | Inner width | | Roller Ø | Pin Ø | Inner link width | Link plate height | Pin length | Length of conn link pin | Bearing area | Required min. breaking strength DIN/ISO | Weight | Individual components | | | | | |
|-------------|---------|-------|---------------------|---------------------|---------------------|---------------------|------------------|---------------------|--------------------|-------------------------|----------------|---|--------|-----------------------|---|---|---|---|--|
| | inch | mm | b ₁ min. | d ₁ max. | d ₂ max. | b ₂ max. | g | a ₁ max. | a ₃ max | A | F _B | ≈ q | A | B | C | E | L | S | |
| | mm | mm | mm | mm | mm | mm | mm | mm | mm | cm ² | N | kg/m | | | | | | | |
| 06 B - 1 SS | 0.375 | 9.52 | 5.72 | 6.35 | 3.28 | 8.53 | 8.2 | 13.5 | 16.8 | 0.28 | 7000 | 0.41 | | | | x | | | |
| 08 B - 1 SS | 0.5 | 12.70 | 7.75 | 8.51 | 4.45 | 11.3 | 11.6 | 17 | 20.9 | 0.5 | 12500 | 0.7 | | | | x | x | | |
| 10 B - 1 SS | 0.625 | 15.87 | 9.65 | 10.16 | 5.08 | 13.28 | 14.6 | 19.6 | 23.7 | 0.67 | 16500 | 0.9 | | | | x | x | | |
| 12 B - 1 SS | 0.75 | 19.05 | 11.68 | 12.07 | 5.72 | 15.62 | 15.9 | 22.7 | 27.3 | 0.89 | 21000 | 1.15 | | | | x | x | | |
| 16 B - 1 SS | 1 | 25.40 | 17.02 | 15.88 | 8.28 | 25.4 | 20.5 | 36.1 | 42.4 | 2.1 | 50000 | 2.6 | | | | x | x | x | |

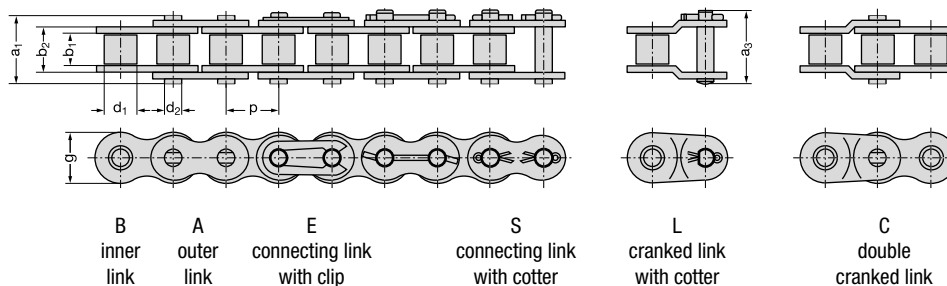

Rust free Roller chains - European type

Approved performance from Rexnord.

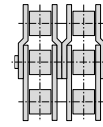

Duplex roller chains



Proven performance

- Fulfills ISO quality requirements
- Rexnord guarantees the achievement of performance requirements
- Optimum choice for light and medium duty



Purchasing policy

- Suppliers must comply with local environmental laws
- Suppliers must comply with Rexnord's ethical policy and internal guidelines
- Suppliers must take local environmental policy into account



Economical

- Good cost-benefit ratio
- Good availability

Duplex roller chains, ISO, rostfrei

| Iso-Nr. | Pitch p | | Inner width | | Roller Ø | Pin Ø | Inner link width | | Link plate height | Mean dimension | Pin length | Length of conn link pin | Bearing area | Required min. breaking strength DIN/ISO | Weight | Components | | | | | |
|-------------|-------------|-------|---------------------|--------------------|---------------------|--------------------|------------------|-------|---------------------|---------------------|------------|-------------------------|--------------|---|--------|------------|---|---|---|--|--|
| | inch | mm | b ₁ min. | d ₁ max | d ₂ max. | b ₂ max | g | e | a ₁ max. | a ₃ max. | A | F _B | ≈ q | A | B | C | E | L | S | | |
| | 08 B - 2 SS | 0.5 | 12.70 | 7.75 | 8.51 | 4.45 | 11.3 | 11.6 | 13.92 | 30.6 | 34.9 | 1.01 | 22000 | 1.4 | | | | x | x | | |
| 10 B - 2 SS | 0.625 | 15.87 | 9.65 | 10.16 | 5.08 | 13.28 | 14.6 | 16.59 | 35.5 | 40.3 | 1.34 | 26000 | 1.8 | | | | x | x | | | |
| 12 B - 2 SS | 0.75 | 19.05 | 11.68 | 12.07 | 5.72 | 15.62 | 15.9 | 19.46 | 41.7 | 46.8 | 1.79 | 33000 | 2.3 | | | | x | x | | | |
| 16 B - 2 SS | 1 | 25.40 | 17.02 | 15.88 | 8.28 | 25.4 | 20.5 | 31.88 | 67.4 | 73.4 | 4.21 | 73000 | 5.3 | | | | x | x | x | | |

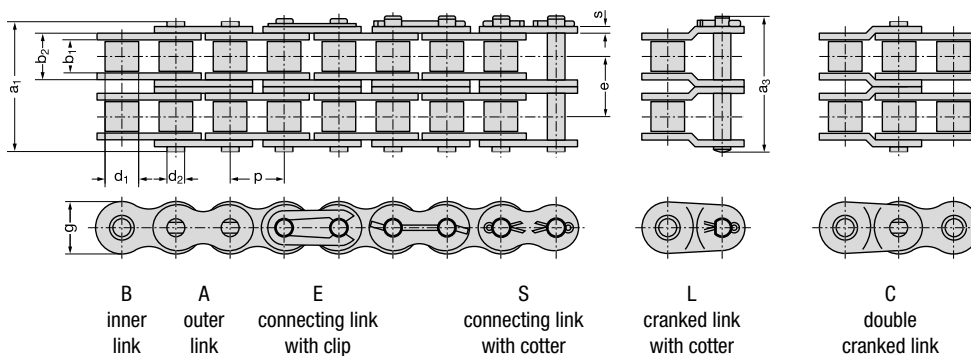



Overview Rexnord roller chains

Roller Chains

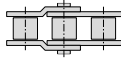

REXNORD
RexPro
 RexPro lubrication
 improved wear resistance
 high fatigue resistance

- Outstanding protection against corrosion and wear
- Unique protection against chain joint stiffness
- Extremely eco-friendly

REXNORD
RexAthletic
 good loading capacity
 extended lubrication intervals

- Durable and low-maintenance
- Longer servicing intervals
- High loading capacity

REXNORD
RexCarbon
 no lubrication
 low noise

- Maintenance-free
- Low noise
- Eco-friendly

REXNORD
RexPlus
 excellent corrosion resistance
 high reliability

- Excellent resistance to rust and acids
- Highly reliable
- Fulfills hygiene requirements
- NSF H1 certification

REXNORD
RexPlusCarbon
 no lubrication
 excellent corrosion resistance

- Combination of RexPlus and RexCarbon
- Excellent resistance to rust and acids
- Maintenance-free
- NSF H1 certification

REXNORD
RexHiPro
 good corrosion resistance
 excellent loading capacity

- Outstanding corrosion resistance
- Long service life
- High loading capacity

Link-Belt
 a brand of
 REXNORD

- The optimum choice for light and medium duty
- Good cost-benefit ratio
- High availability

REXNORD
RexProX
 RexPro lubrication
 improved wear resistance
 high fatigue resistance

- Extremely high loading capacity
- Long service life
- Outstanding protection against corrosion and wear

Flyer Chains

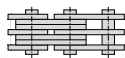

REXNORD
RexPro
 RexPro lubrication
 improved wear resistance
 high fatigue resistance

- Outstanding protection against corrosion and wear
- Unique protection against chain joint stiffness
- Extremely eco-friendly

REXNORD
RexHiPro
 good corrosion resistance
 excellent loading capacity

- Outstanding corrosion resistance
- Long service life
- High loading capacity

REXNORD
RexDura
 improved wear resistance
 lubrication stay in chain hinge

- Durable and low-maintenance
- Longer servicing intervals
- High loading capacity
- Extreme wear resistance for double-length service life

REXDL
 a brand of
 REXNORD

- The optimum choice for light and medium duty
- Good cost-benefit ratio
- Good availability



Approved Performance from Rexnord

Roller chains | American type | Rust free



Rust-free Roller chains - American type

Approved performance from Rexnord.

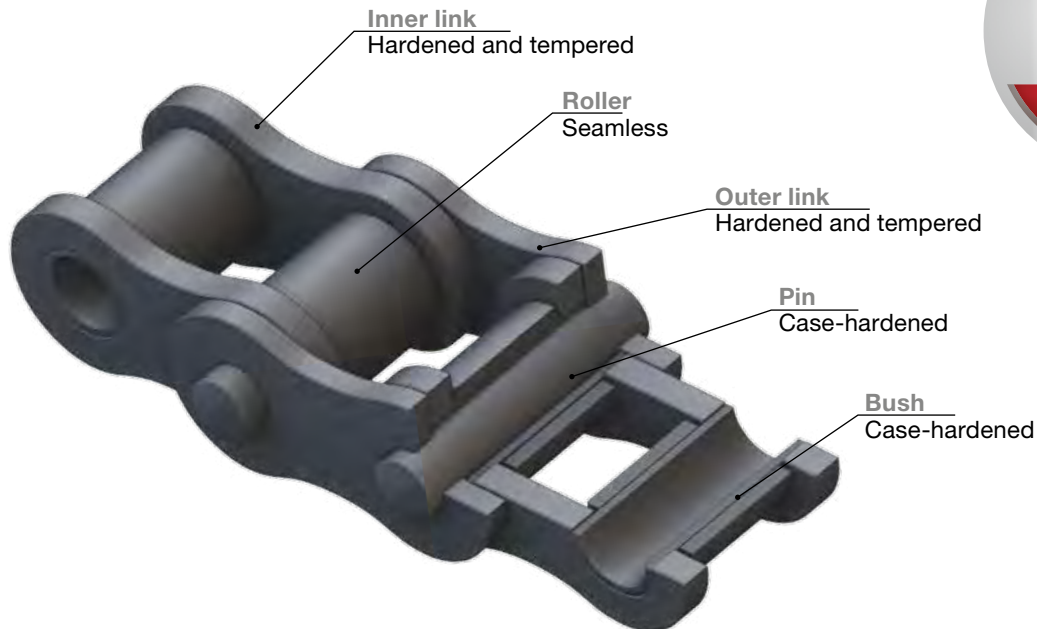

APPLICATIONS

- Light and medium duty
- Agricultural machinery, wood processing
- Textile industry

CHARACTERISTICS

- Established brand name
- Fulfils ISO quality requirements
- Rexnord guarantees achievement of performance requirements

ADVANTAGES

- Good cost-benefit ratio
- Good availability
- Robust quality

LUBRICATION

- Contains no heavy metals
- Fulfils REACH requirements



Overview Rexnord roller chains

Roller Chains

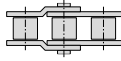

REXNORD

RexPro
RexPro lubrication
improved wear resistance
high fatigue resistance

- Outstanding protection against corrosion and wear
- Unique protection against chain joint stiffness
- Extremely eco-friendly

REXNORD

RexAthletic
good loading capacity
extended lubrication intervals

- Durable and low-maintenance
- Longer servicing intervals
- High loading capacity

REXNORD

RexCarbon
no lubrication
low noise

- Maintenance-free
- Low noise
- Eco-friendly

REXNORD

RexPlus
excellent corrosion resistance
high reliability

- Excellent resistance to rust and acids
- Highly reliable
- Fulfills hygiene requirements
- NSF H1 certification

REXNORD

RexPlusCarbon
no lubrication
excellent corrosion resistance

- Combination of RexPlus and RexCarbon
- Excellent resistance to rust and acids
- Maintenance-free
- NSF H1 certification

REXNORD

RexHiPro
good corrosion resistance
excellent loading capacity

- Outstanding corrosion resistance
- Long service life
- High loading capacity

Link-Belt
a brand of REXNORD

- The optimum choice for light and medium duty
- Good cost-benefit ratio
- High availability

REXNORD

RexProX
RexPro lubrication
improved wear resistance
high fatigue resistance

- Extremely high loading capacity
- Long service life
- Outstanding protection against corrosion and wear

Flyer Chains

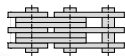

REXNORD

RexPro
RexPro lubrication
improved wear resistance
high fatigue resistance

- Outstanding protection against corrosion and wear
- Unique protection against chain joint stiffness
- Extremely eco-friendly

REXNORD

RexHiPro
good corrosion resistance
excellent loading capacity

- Outstanding corrosion resistance
- Long service life
- High loading capacity

REXNORD

RexDura
improved wear resistance
lubrication stay in chain hinge

- Durable and low-maintenance
- Longer servicing intervals
- High loading capacity
- Extreme wear resistance for double-length service life

REXDL
a brand of REXNORD

- The optimum choice for light and medium duty
- Good cost-benefit ratio
- Good availability



Approved Performance from Rexnord

Roller chains with straight link plates



Excellent corrosion
resistance,
maximum operating
reliability

Roller chains with straight link plates

Approved performance from Rexnord.

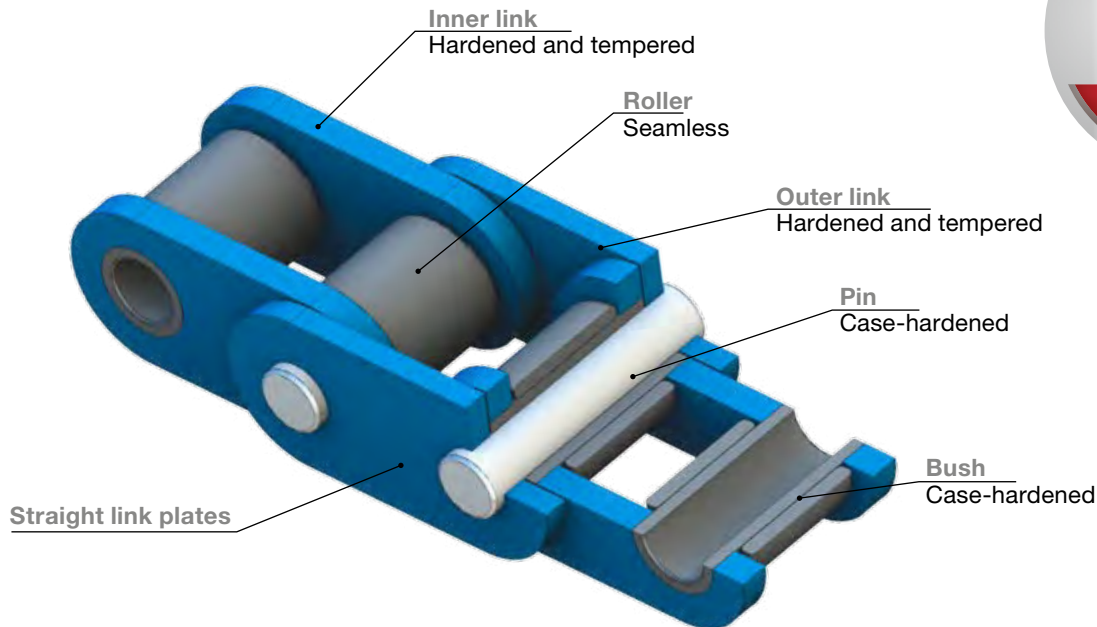

APPLICATIONS

- Light and medium duty
- Agricultural machinery, wood processing
- Textile industry

CHARACTERISTICS

- Established brand name
- Fulfils ISO quality requirements
- Rexnord guarantees achievement of performance requirements

ADVANTAGES

- Good cost-benefit ratio
- Good availability
- Robust quality

LUBRICATION

- Contains no heavy metals
- Fulfils REACH requirements

Roller chains with straight link plates

Approved performance from Rexnord.

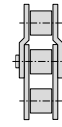

Simplex roller chains



Proven performance

- Fulfills ISO quality requirements
- Rexnord guarantees the achievement of performance requirements
- Optimum choice for light and medium duty



Purchasing policy

- Suppliers must comply with local environmental laws
- Suppliers must comply with Rexnord's ethical policy and internal guidelines
- Suppliers must take local environmental policy into account



Economical

- Good cost-benefit ratio
- Good availability



Simplex roller chains with straight link plates, ISO 606 / DIN 8187 / DIN 8188

| Chain No. | Pitch p | | Inner width | | Roller Ø | Pin Ø | Inner link width | | Link plate height | Mean dimension | Pin length | Locking Pin length | Bearing area | Required min. breaking strength DIN/ISO | Weight | Individual components | | | | | |
|-------------|---------|--------|---------------------|---------------------|---------------------|---------------------|------------------|----|---------------------|---------------------|------------|--------------------|-----------------|---|--------|-----------------------|---|---|---|---|--|
| | inch | mm | b ₁ min. | d ₁ max. | d ₂ max. | b ₂ max. | g | e | a ₁ max. | a ₃ max. | A | F _B | ≈ q | A | B | C | E | G | L | S | |
| | mm | mm | mm | mm | mm | mm | mm | mm | mm | mm | mm | mm | cm ² | N | kg/m | | | | | | |
| 06 B - 1 GL | 0.375 | 9.525 | 5.72 | 6.35 | 3.28 | 8.53 | 8.1 | - | 12.8 | 15.8 | 0.28 | 9 000 | 0.42 | | | | x | | | x | |
| 10 B - 1 GL | 0.625 | 15.875 | 9.65 | 10.16 | 5.08 | 13.28 | 13.9 | - | 18.9 | 22 | 0.67 | 22 400 | 1 | | | | x | | | x | |
| 12 B - 1 GL | 0.75 | 19.05 | 11.68 | 12.07 | 5.72 | 15.62 | 15.9 | - | 22.3 | 25.1 | 0.89 | 29 000 | 1.33 | | | | x | | | x | |
| 16 B - 1 GL | 1 | 25.4 | 17.02 | 15.88 | 8.28 | 25.4 | 20.3 | - | 35.4 | 42.4 | 2.1 | 60 000 | 2.85 | | | | x | | | x | |

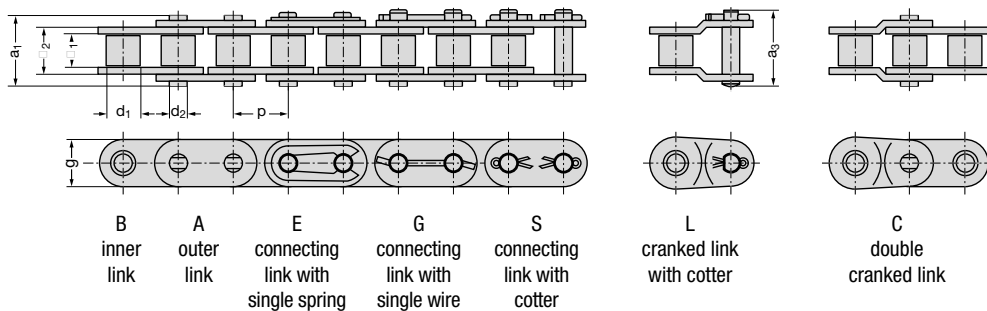

Overview Rexnord roller chains

Roller Chains

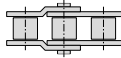

REXNORD
RexPro
RexPro lubrication
improved wear resistance
high fatigue resistance

- Outstanding protection against corrosion and wear
- Unique protection against chain joint stiffness
- Extremely eco-friendly

REXNORD
RexAthletic
good loading capacity
extended lubrication intervals

- Durable and low-maintenance
- Longer servicing intervals
- High loading capacity

REXNORD
RexCarbon
no lubrication
low noise

- Maintenance-free
- Low noise
- Eco-friendly

REXNORD
RexPlus
excellent corrosion resistance
high reliability

- Excellent resistance to rust and acids
- Highly reliable
- Fulfills hygiene requirements
- NSF H1 certification

REXNORD
RexPlusCarbon
no lubrication
excellent corrosion resistance

- Combination of RexPlus and RexCarbon
- Excellent resistance to rust and acids
- Maintenance-free
- NSF H1 certification

REXNORD
RexHiPro
good corrosion resistance
excellent loading capacity

- Outstanding corrosion resistance
- Long service life
- High loading capacity

Link-Belt
a brand of
REXNORD

- The optimum choice for light and medium duty
- Good cost-benefit ratio
- High availability

REXNORD
RexProX
RexPro lubrication
improved wear resistance
high fatigue resistance

- Extremely high loading capacity
- Long service life
- Outstanding protection against corrosion and wear

Flyer Chains

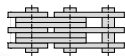

REXNORD
RexPro
RexPro lubrication
improved wear resistance
high fatigue resistance

- Outstanding protection against corrosion and wear
- Unique protection against chain joint stiffness
- Extremely eco-friendly

REXNORD
RexHiPro
good corrosion resistance
excellent loading capacity

- Outstanding corrosion resistance
- Long service life
- High loading capacity

REXNORD
RexDura
improved wear resistance
lubrication stay in chain hinge

- Durable and low-maintenance
- Longer servicing intervals
- High loading capacity
- Extreme wear resistance for double-length service life

REXDL
a brand of
REXNORD

- The optimum choice for light and medium duty
- Good cost-benefit ratio
- Good availability



Approved Performance from Rexnord

Double pitch roller chains



Double pitch roller chains

Approved performance from Rexnord.

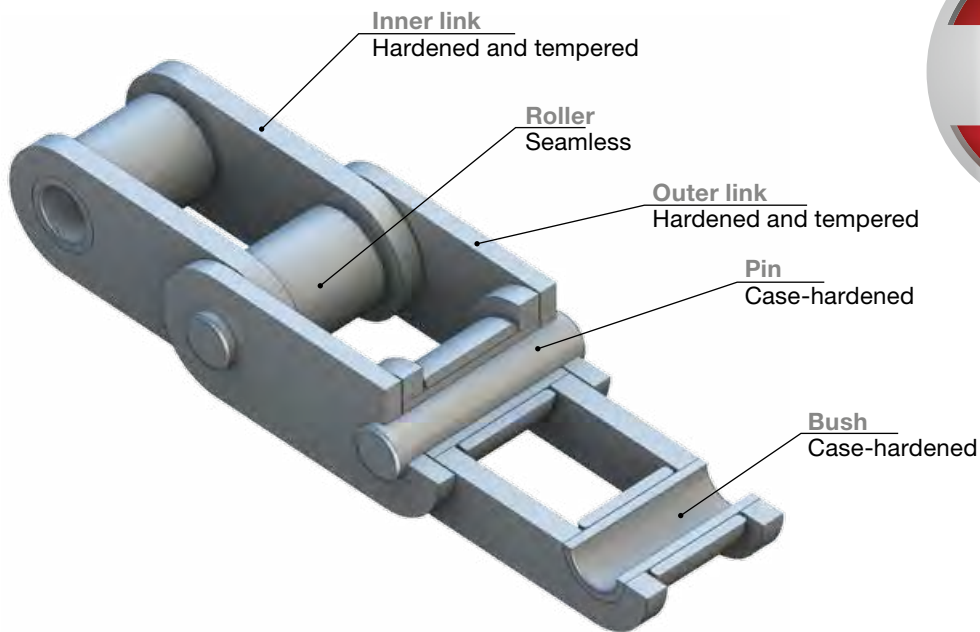

APPLICATIONS

- Light and medium duty
- Agricultural machinery, wood processing
- Textile industry

CHARACTERISTICS

- Established brand name
- Fulfils ISO quality requirements
- Rexnord guarantees achievement of performance requirements

ADVANTAGES

- Good cost-benefit ratio
- Good availability
- Robust quality

LUBRICATION

- Contains no heavy metals
- Fulfils REACH requirements

Double pitch roller chains - American type

Approved performance from Rexnord.



Proven performance

- Fulfills ISO quality requirements
- Rexnord guarantees the achievement of performance requirements
- Optimum choice for light and medium duty



Purchasing policy

- Suppliers must comply with local environmental laws
- Suppliers must comply with Rexnord's ethical policy and internal guidelines
- Suppliers must take local environmental policy into account



Economical

- Good cost-benefit ratio
- Good availability

Double pitch roller chains - European type, ISO 1275 / DIN 8187

| Chain No. | Pitch p | | Inner width | | Roller \varnothing | Pin \varnothing | Inner link width | Link plate height | Pin length | Length of conn link pin | Bearing area | Required min. breaking strength DIN/ISO | Weight | Individual components | | | | | | | |
|-----------|---------|-------|-------------|------------|----------------------|-------------------|------------------|-------------------|------------|-------------------------|--------------|---|--------|-----------------------|---|---|---|---|---|--|--|
| | inch | mm | b_1 min. | d_1 max. | d_2 max. | b_2 max. | g | a_1 max. | a_3 max. | A | F_B | $\approx q$ | A | B | C | E | G | L | S | | |
| | | | mm | mm | mm | mm | mm | mm | mm | mm | mm | cm ² | N | kg/m | | | | | | | |
| 208 A | 1.00 | 25.4 | 7.85 | 7.95 | 3.96 | 11.15 | 11.15 | 16.3 | 19.8 | 0.44 | 14 100 | 0.42 | | | | x | x | x | x | | |
| 210 A | 1.25 | 31.75 | 9.40 | 10.16 | 5.08 | 13.8 | 14.5 | 20.3 | 24.5 | 0.70 | 22 200 | 0.67 | | | | x | x | x | x | | |
| 212 A | 1.50 | 38.1 | 12.57 | 11.91 | 5.94 | 17.7 | 16.8 | 25.7 | 29.6 | 1.05 | 31 800 | 1.02 | | | | x | x | x | x | | |
| 216 A | 2.00 | 50.8 | 15.75 | 15.88 | 7.92 | 22.5 | 21.4 | 33.0 | 37.4 | 1.78 | 56 700 | 1.55 | | | | | x | x | x | | |

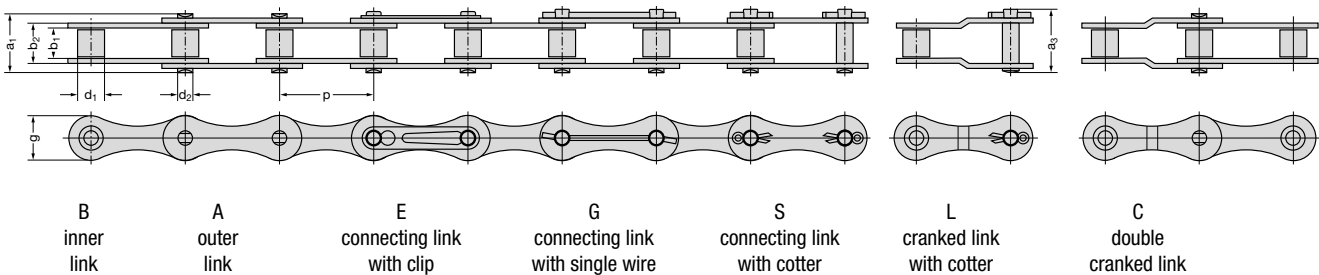

Double pitch roller chains with straight link plates and track rollers

Approved performance from Rexnord.



Proven performance

- Fulfills ISO quality requirements
- Rexnord guarantees the achievement of performance requirements
- Optimum choice for light and medium duty



Purchasing policy

- Suppliers must comply with local environmental laws
- Suppliers must comply with Rexnord's ethical policy and internal guidelines
- Suppliers must take local environmental policy into account



Economical

- Good cost-benefit ratio
- Good availability



Double pitch roller chains with straight link plates and track rollers, ISO 1275

| Chain No. | Pitch p | | Inner width | Roller Ø | Pin Ø | Inner link width | Link plate height | Pin length | Length of conn link pin | Bearing area | Required min. breaking strength DIN/ISO | Weight | Individual components | | | | | | | |
|-----------|---------|-------|-------------|----------|-------|------------------|-------------------|------------|-------------------------|--------------|---|--------|-----------------------|---------------------|---------------------|---------------------|---|---------------------|---------------------|---|
| | inch | mm | | | | | | | | | | | b ₁ min. | d ₁ max. | d ₂ max. | b ₂ max. | g | a ₁ max. | a ₃ max. | A |
| | C 2042 | 1.00 | 25.4 | 7.85 | 15.88 | 3.96 | 11.15 | 11.5 | 16.3 | 20.3 | 0.44 | 14 100 | 0.85 | | | | | x | x | x |
| C 2052 | 1.25 | 31.75 | 9.40 | 19.05 | 5.08 | 13.8 | 14.5 | 20.3 | 24.5 | 0.70 | 22 200 | 1.27 | | | | | x | x | x | x |
| C 2062 H | 1.50 | 38.1 | 12.57 | 22.23 | 5.94 | 19.4 | 16.8 | 28.8 | 32.0 | 1.15 | 31 800 | 2.10 | | | | | x | x | x | x |
| C 2082 H | 2.00 | 50.8 | 15.75 | 28.58 | 7.93 | 24.2 | 22.8 | 35.9 | 41.0 | 1.94 | 56 700 | 3.44 | | | | | | x | | x |

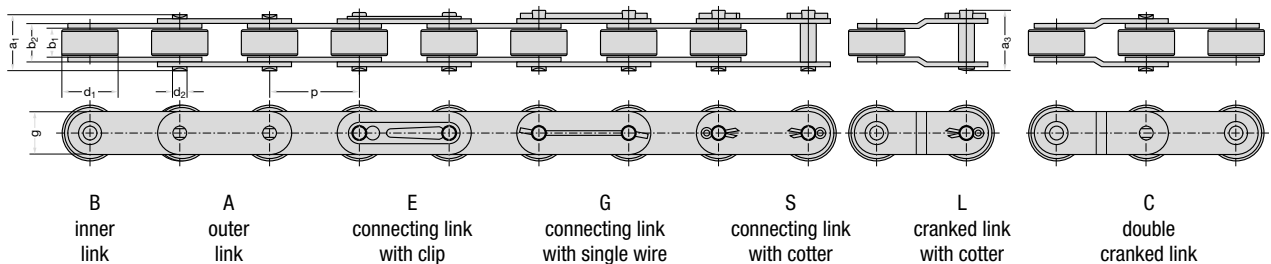

Double pitch roller chains with straight link plates

Approved performance from Rexnord.



Proven performance

- Fulfills ISO quality requirements
- Rexnord guarantees the achievement of performance requirements
- Optimum choice for light and medium duty



Purchasing policy

- Suppliers must comply with local environmental laws
- Suppliers must comply with Rexnord's ethical policy and internal guidelines
- Suppliers must take local environmental policy into account



Economical

- Good cost-benefit ratio
- Good availability

Double pitch roller chains with straight link plates, ISO 1275

| Chain No. | Pitch p | | Inner width | | Roller \varnothing | Pin \varnothing | Inner link width | | Link plate height | Pin length | Length of conn link pin | Bearing area | Required min. breaking strength DIN/ISO | Weight | Individual components | | | | | | |
|-----------|---------|-------|-------------|------------|----------------------|-------------------|------------------|------------|-------------------|------------|-------------------------|--------------|---|--------|-----------------------|---|---|---|---|----|----|
| | inch | mm | b_1 min. | d_1 max. | d_2 max. | b_2 max. | g | a_1 max. | a_3 max. | A | F_B | $\approx q$ | A | B | C | E | G | L | S | | |
| | | | mm | mm | | | | | | | | | | | | | | | | mm | mm |
| C 2040 | 1.00 | 25.4 | 7.85 | 7.95 | 3.96 | 11.15 | 11.5 | 16.3 | 20.3 | 0.44 | 14 100 | 0.48 | | | | x | x | x | x | | |
| C 2050 | 1.25 | 31.75 | 9.40 | 10.16 | 5.08 | 13.8 | 14.5 | 20.3 | 24.5 | 0.70 | 22 200 | 0.80 | | | | x | x | x | x | | |
| C 2060 H | 1.50 | 38.1 | 12.57 | 11.91 | 5.94 | 19.4 | 16.8 | 28.8 | 32.9 | 1.15 | 31.800 | 1.49 | | | | x | x | x | x | | |
| C 2080 H | 2.00 | 50.8 | 15.75 | 15.88 | 7.92 | 24.2 | 22.8 | 35.3 | 41.0 | 1.93 | 56 700 | 2.36 | | | | | x | | x | | |

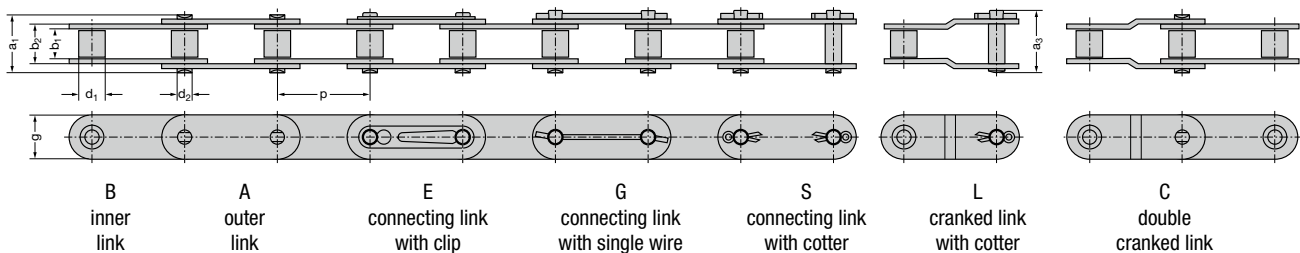



Overview Rexnord roller chains

Roller Chains

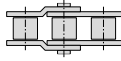

REXNORD
RexPro
 RexPro lubrication
 improved wear resistance
 high fatigue resistance

- Outstanding protection against corrosion and wear
- Unique protection against chain joint stiffness
- Extremely eco-friendly

REXNORD
RexAthletic
 good loading capacity
 extended lubrication intervals

- Durable and low-maintenance
- Longer servicing intervals
- High loading capacity

REXNORD
RexCarbon
 no lubrication
 low noise

- Maintenance-free
- Low noise
- Eco-friendly

REXNORD
RexPlus
 excellent corrosion resistance
 high reliability

- Excellent resistance to rust and acids
- Highly reliable
- Fulfills hygiene requirements
- NSF H1 certification

REXNORD
RexPlusCarbon
 no lubrication
 excellent corrosion resistance

- Combination of RexPlus and RexCarbon
- Excellent resistance to rust and acids
- Maintenance-free
- NSF H1 certification

REXNORD
RexHiPro
 good corrosion resistance
 excellent loading capacity

- Outstanding corrosion resistance
- Long service life
- High loading capacity

Link-Belt
 a brand of
 REXNORD

- The optimum choice for light and medium duty
- Good cost-benefit ratio
- High availability

REXNORD
RexProX
 RexPro lubrication
 improved wear resistance
 high fatigue resistance

- Extremely high loading capacity
- Long service life
- Outstanding protection against corrosion and wear

Flyer Chains

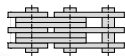

REXNORD
RexPro
 RexPro lubrication
 improved wear resistance
 high fatigue resistance

- Outstanding protection against corrosion and wear
- Unique protection against chain joint stiffness
- Extremely eco-friendly

REXNORD
RexHiPro
 good corrosion resistance
 excellent loading capacity

- Outstanding corrosion resistance
- Long service life
- High loading capacity

REXNORD
RexDura
 improved wear resistance
 lubrication stay in chain hinge

- Durable and low-maintenance
- Longer servicing intervals
- High loading capacity
- Extreme wear resistance for double-length service life

REXDL
 a brand of
 REXNORD

- The optimum choice for light and medium duty
- Good cost-benefit ratio
- Good availability