

SIMPLE CHAIN SPROCKETS WITH HARDENED TEETH WITH HOLE + KEYWAY + SCREW HOLES



5/8" x 3/8" 10B-1

CHAIN SPROCKETS

Sprockets tooth width B_1 9,1 mm

CHAIN

Pitch 15,875 mm

Inner width 9,65 mm

Roller \varnothing 10,16 mm

KEYWAY DIN 6885 UNI 6604

Hardened teeth HRC 45÷53

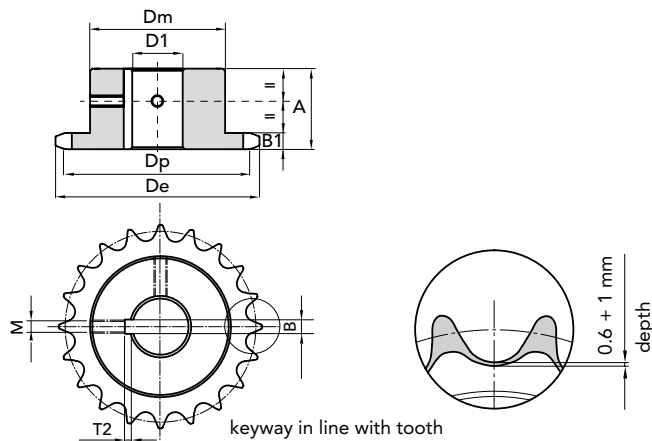

SIMPLE CHAIN SPROCKETS 5/8"x3/8" 10B-1 for roller chains in compliance with DIN 8187 - ISO/R 606

Z	P. NUMBER	d_e	d_p	d_m	A	$\varnothing D1$ H7	B H9	T2	M	Z	P. NUMBER	d_e	d_p	d_m	A	$\varnothing D1$ H7	B H9	T2	M
12	16151216	68,2	61,34	42	30	16	5	2,3	M4	16	16151620	88	81,37	60	30	20	6	2,8	M5
	16151219					19	6	2,8	M5		16151622					22	6	2,8	M5
	16151220					20	6	2,8	M5		16151624					24	8	3,3	M6
	16151222					22	6	2,8	M5		16151625					25	8	3,3	M6
	16151224					24	8	3,3	M6		16151628					28	8	3,3	M6
	16151225					25	8	3,3	M6		16151630					30	8	3,3	M6
	16151228			51		28	8	3,3	M6		16151632					32	10	3,3	M8
	16151230			51		30	8	3,3	M6		16151635					35	10	3,3	M8
13	16151316	73,2	66,32	47	30	16	5	2,3	M4	17	16151720	93,2	86,39	60	30	20	6	2,8	M5
	16151319					19	6	2,8	M5		16151722					22	6	2,8	M5
	16151320					20	6	2,8	M5		16151724					24	8	3,3	M6
	16151322					22	6	2,8	M5		16151725					25	8	3,3	M6
	16151324					24	8	3,3	M6		16151728					28	8	3,3	M6
	16151325					25	8	3,3	M6		16151730					30	8	3,3	M6
	16151328					28	8	3,3	M6		16151732					32	10	3,3	M8
	16151330					30	8	3,3	M6		16151735					35	10	3,3	M8
14	16151416	78,2	71,34	52	30	16	5	2,3	M4	18	16151820	98,3	91,42	70	30	20	6	2,8	M5
	16151419					19	6	2,8	M5		16151822					22	6	2,8	M5
	16151420					20	6	2,8	M5		16151824					24	8	3,3	M6
	16151422					22	6	2,8	M5		16151825					25	8	3,3	M6
	16151424					24	8	3,3	M6		16151828					28	8	3,3	M6
	16151425					25	8	3,3	M6		16151830					30	8	3,3	M6
	16151428					28	8	3,3	M6		16151832					32	10	3,3	M8
	16151430					30	8	3,3	M6		16151835					35	10	3,3	M8
15	16151519	83,2	76,36	57	30	19	6	2,8	M5		16151838					38	10	3,3	M8
	16151520					20	6	2,8	M5		16151840					40	12	3,3	M10
	16151522					22	6	2,8	M5	19	16151920	103,3	96,45	70	30	20	6	2,8	M5
	16151524					24	8	3,3	M6		16151922					22	6	2,8	M5
	16151525					25	8	3,3	M6		16151924					24	8	3,3	M6
	16151528					28	8	3,3	M6		16151925					25	8	3,3	M6
	16151530					30	8	3,3	M6		16151928					28	8	3,3	M6
	16151532					32	10	3,3	M8		16151930					30	8	3,3	M6
	16151535					35	10	3,3	M8		16151932					32	10	3,3	M8
											16151935					35	10	3,3	M8
											16151938					38	10	3,3	M8
											16151940					40	12	3,3	M10

MATERIAL **C 45 UNI 7845**

CAD drawings available on our site
www.chiaravalli.com

Quantity, availability and prices
 on B2B Chiaravalli





SIMPLE CHAIN SPROCKETS WITH HARDENED TEETH WITH HOLE + KEYWAY + SCREW HOLES

5/8" x 3/8" 10B-1

CHAIN SPROCKETS

Sprockets tooth width B_1 9,1 mm

CHAIN

Pitch 15,875 mm

Inner width 9,65 mm

Roller \varnothing 10,16 mm

KEYWAY DIN 6885 UNI 6604

Hardened teeth HRC 45÷53

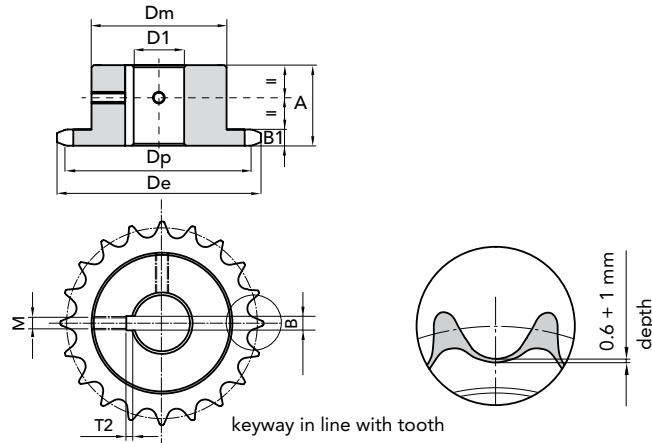

Z	P. NUMBER	d_e	d_p	dm	A	$\varnothing D1$ H7	B H9	T2	M
20	16152020	108,4	101,49	75	30	20	6	2,8	M5
	16152022					22	6	2,8	M5
	16152024					24	8	3,3	M6
	16152025					25	8	3,3	M6
	16152028					28	8	3,3	M6
	16152030					30	8	3,3	M6
	16152032					32	10	3,3	M8
	16152035					35	10	3,3	M8
	16152038					38	10	3,3	M8
	16152040					40	12	3,3	M10
21	16152120	113,4	106,52	75	30	20	6	2,8	M5
	16152122					22	6	2,8	M5
	16152124					24	8	3,3	M6
	16152125					25	8	3,3	M6
	16152128					28	8	3,3	M6
	16152130					30	8	3,3	M6
	16152132					32	10	3,3	M8
	16152135					35	10	3,3	M8
	16152138					38	10	3,3	M8
	16152140					40	12	3,3	M10
23	16152320	123,4	116,58	80	30	20	6	2,8	M5
	16152322					22	6	2,8	M5
	16152324					24	8	3,3	M6
	16152325					25	8	3,3	M6
	16152328					28	8	3,3	M6
	16152330					30	8	3,3	M6
	16152332					32	10	3,3	M8
	16152335					35	10	3,3	M8
	16152338					38	10	3,3	M8
	16152340					40	12	3,3	M10
	16152342					42	12	3,3	M10

Z	P. NUMBER	d_e	d_p	dm	A	$\varnothing D1$ H7	B H9	T2	M
24	16152420	128,5	121,62	80	30	20	6	2,8	M5
	16152422					22	6	2,8	M5
	16152424					24	8	3,3	M6
	16152425					25	8	3,3	M6
	16152428					28	8	3,3	M6
	16152430					30	8	3,3	M6
	16152432					32	10	3,3	M8
	16152435					35	10	3,3	M8
	16152438					38	10	3,3	M8
	16152440					40	12	3,3	M10
	16152442					42	12	3,3	M10
25	16152522	133,5	126,66	80	30	22	6	2,8	M5
	16152524					24	8	3,3	M6
	16152525					25	8	3,3	M6
	16152528					28	8	3,3	M6
	16152530					30	8	3,3	M6
	16152532					32	10	3,3	M8
	16152535					35	10	3,3	M8
	16152538					38	10	3,3	M8
	16152540					40	12	3,3	M10
	16152542					42	12	3,3	M10

SIMPLE CHAIN SPROCKETS 5/8"x3/8" 10B-1 for roller chains in compliance with DIN 8187 - ISO/R 606

MATERIAL **C 45 UNI 7845**

CAD drawings available on our site
www.chiaravalli.com

Quantity, availability and prices
on B2B Chiaravalli

