

**RIDUTTORI  
EPICICLOIDALI**

**PLANETARY  
GEARBOXES**



[www.chiaravalli.com](http://www.chiaravalli.com)

Il nostro centro logistico in Cavaria con Premezzo (Cantalupa) è un insieme di funzioni informatiche dedicate allo stoccaggio dei prodotti, al loro prelevamento, al loro confezionamento ed alla loro spedizione.

Tutte le funzioni sono state automatizzate ai più alti livelli oggi disponibili.

#### TRASMISSIONI STANDARD

Prodotti standard a catalogo



#### RIDUTTORI & MOTORI ELETTRICI

Prodotti standard a catalogo



#### MARTINETTI MECCANICI

Prodotti standard a catalogo personalizzabili



#### COMPONENTI SPECIALI

Produzione di particolari meccanici di grande complessità ed altissima precisione



#### DIVISIONE MOTO

Distribuzione equipaggiamento moto



La logistica Chiaravalli Group si è affermata nel tempo come elemento di comparazione e traguardo per tutte le aziende europee del settore meccanico.



# ELECTRICAL

# MOTORS AND GEARBOXES

*A large range of motors and gearboxes developed by Chiaravalli Group SpA and managed by our Logistics in Cavarina con Premezzo (Cantalupa).*

*We are able to supply and send any item to catalogue, in over 52 countries, with a minimum lead-time from order receipt.*



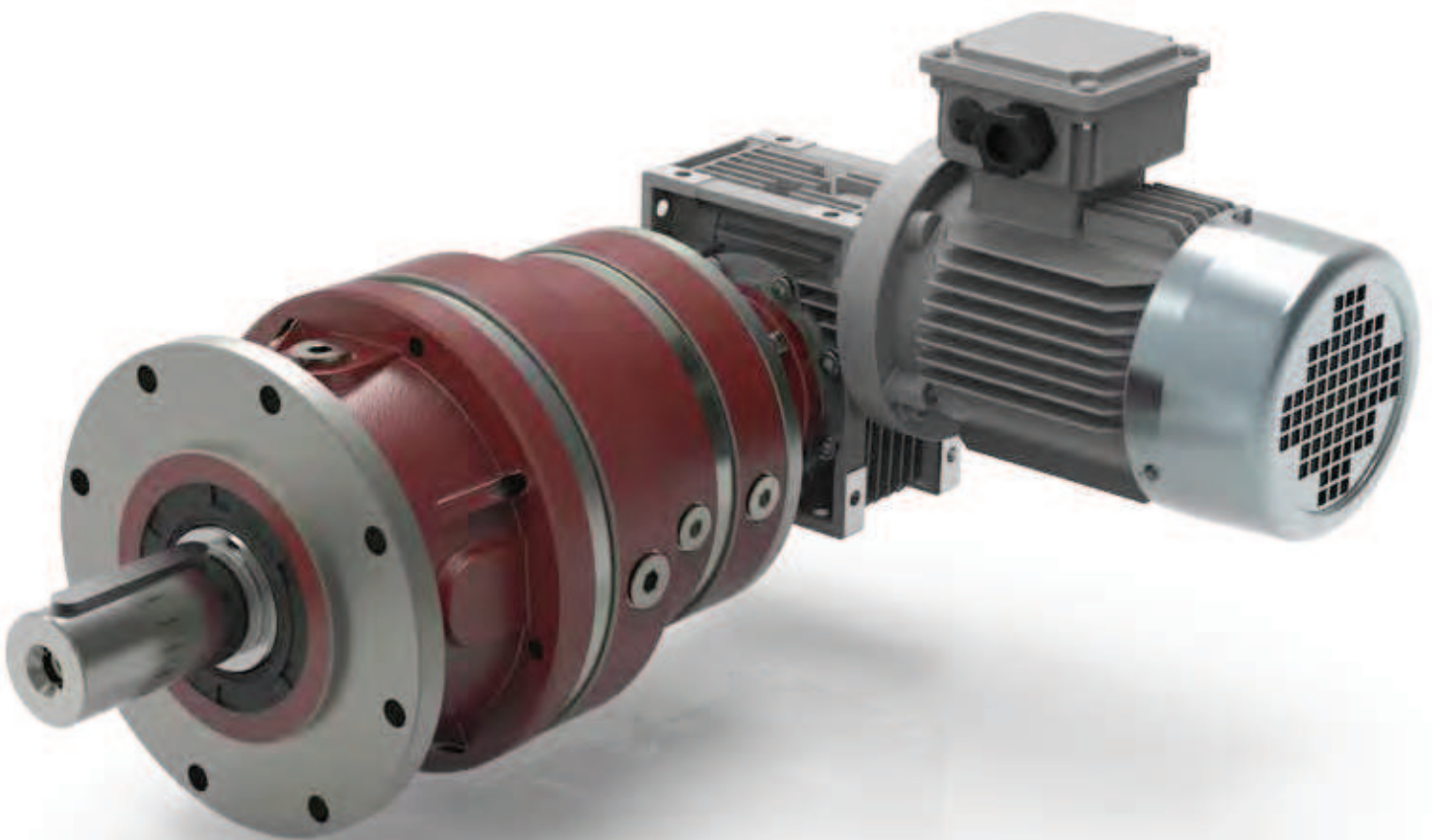



## INDICE DEI CONTENUTI

## INDEX OF CONTENT

Indice	Index	
<b>A Introduzione</b>	<b>Introduction</b>	<b>A1</b>
	Designazione	A2
	Caratteristiche tecniche	A6
	Installazione e manutenzione	A10
	Lubrificazione	A12
	Posizioni di montaggio	A18
<b>B CHPL/CHPLB 1000</b>		<b>B1</b>
	Dati tecnici	B2
	Dimensioni uscita CMS	B4
	Dimensioni uscita CMC	B6
	Dimensioni uscita CPS	B8
	Dimensioni uscita CPC	B10
	Dimensioni uscita CF	B12
	Dimensioni uscita CFS	B14
	Dimensioni uscita CCPC	B16
	Accessori	B18
	Carichi in uscita	B19
<b>C CHPL/CHPLB 1600</b>		<b>C1</b>
	Dati tecnici	C2
	Dimensioni uscita CMS	C4
	Dimensioni uscita CMC	C6
	Dimensioni uscita CPS	C8
	Dimensioni uscita CPC	C10
	Dimensioni uscita CF	C12
	Dimensioni uscita CFS	C14
	Dimensioni uscita CCPC	C16
	Accessori	C18
	Carichi in uscita	C19
<b>D CHPL/CHPLB 2500</b>		<b>D1</b>
	Dati tecnici	D2
	Dimensioni uscita CMS	D4
	Dimensioni uscita CMC	D6
	Dimensioni uscita CPS	D8
	Dimensioni uscita CPC	D10
	Dimensioni uscita CF	D12
	Dimensioni uscita CFS	D14
	Dimensioni uscita CCPC	D16
	Accessori	D18
	Carichi in uscita	D19



### INDICE DEI CONTENUTI

### INDEX OF CONTENT

<b>E</b>	<b>CHPL/CHPLB 5000</b>		<b>E1</b>
	Dati tecnici	<i>Technical data</i>	<b>E2</b>
	Dimensioni uscita CMS	<i>CMS Output dimensions</i>	<b>E4</b>
	Dimensioni uscita CMC	<i>CMC Output dimensions</i>	<b>E6</b>
	Dimensioni uscita CPS	<i>CPS Output dimensions</i>	<b>E8</b>
	Dimensioni uscita CPC	<i>CPC Output dimensions</i>	<b>E10</b>
	Dimensioni uscita CF	<i>CF Output dimensions</i>	<b>E12</b>
	Dimensioni uscita CFS	<i>CFS Output dimensions</i>	<b>E14</b>
	Dimensioni uscita CCPC	<i>CCPC Output dimensions</i>	<b>E16</b>
	Accessori	<i>Accessories</i>	<b>E18</b>
	Carichi in uscita	<i>Output loads</i>	<b>E19</b>
<b>F</b>	<b>CHPL/CHPLB 7000</b>		<b>F1</b>
	Dati tecnici	<i>Technical data</i>	<b>F2</b>
	Dimensioni uscita CPS	<i>CPS Output dimensions</i>	<b>F4</b>
	Dimensioni uscita CPC	<i>CPC Output dimensions</i>	<b>F6</b>
	Dimensioni uscita CF	<i>CF Output dimensions</i>	<b>F8</b>
	Dimensioni uscita CFS	<i>CFS Output dimensions</i>	<b>F10</b>
	Dimensioni uscita CCPC	<i>CCPC Output dimensions</i>	<b>F12</b>
	Accessori	<i>Accessories</i>	<b>F14</b>
	Carichi in uscita	<i>Output loads</i>	<b>F15</b>
<b>G</b>	<b>CHPL/CHPLB 10000</b>		<b>G1</b>
	Dati tecnici	<i>Technical data</i>	<b>G2</b>
	Dimensioni uscita CMS	<i>CMS Output dimensions</i>	<b>G4</b>
	Dimensioni uscita CMC	<i>CMC Output dimensions</i>	<b>G6</b>
	Dimensioni uscita CF	<i>CF Output dimensions</i>	<b>G8</b>
	Dimensioni uscita CFS	<i>CFS Output dimensions</i>	<b>G10</b>
	Dimensioni uscita CCPC	<i>CCPC Output dimensions</i>	<b>G12</b>
	Accessori	<i>Accessories</i>	<b>G14</b>
	Carichi in uscita	<i>Output loads</i>	<b>G15</b>
<b>H</b>	<b>CHPL/CHPLB 16000</b>		<b>H1</b>
	Dati tecnici	<i>Technical data</i>	<b>H2</b>
	Dimensioni uscita CMS	<i>CMS Output dimensions</i>	<b>H4</b>
	Dimensioni uscita CMC	<i>CMC Output dimensions</i>	<b>H6</b>
	Dimensioni uscita CPS	<i>CPS Output dimensions</i>	<b>H8</b>
	Dimensioni uscita CPC	<i>CPC Output dimensions</i>	<b>H10</b>
	Dimensioni uscita CF	<i>CF Output dimensions</i>	<b>H12</b>
	Dimensioni uscita CFS	<i>CFS Output dimensions</i>	<b>H14</b>
	Dimensioni uscita CCPC	<i>CCPC Output dimensions</i>	<b>H16</b>
	Accessori	<i>Accessories</i>	<b>H18</b>
	Carichi in uscita	<i>Output loads</i>	<b>H19</b>
<b>I</b>	<b>CHPL/CHPLB 18000</b>		<b>I1</b>
	Dati tecnici	<i>Technical data</i>	<b>I2</b>
	Dimensioni uscita CMS	<i>CMS Output dimensions</i>	<b>I4</b>
	Dimensioni uscita CMC	<i>CMC Output dimensions</i>	<b>I6</b>
	Dimensioni uscita CPS	<i>CPS Output dimensions</i>	<b>I8</b>
	Dimensioni uscita CPC	<i>CPC Output dimensions</i>	<b>I10</b>
	Dimensioni uscita CF	<i>CF Output dimensions</i>	<b>I12</b>
	Dimensioni uscita CFS	<i>CFS Output dimensions</i>	<b>I14</b>
	Dimensioni uscita CCPC	<i>CCPC Output dimensions</i>	<b>I16</b>
	Accessori	<i>Accessories</i>	<b>I18</b>
	Carichi in uscita	<i>Output loads</i>	<b>I19</b>



## INDICE DEI CONTENUTI

## INDEX OF CONTENT

<b>L CHPL/CHPLB 25000</b>			<b>L1</b>
	Dati tecnici	<i>Technical data</i>	<b>L2</b>
	Dimensioni uscita CMS	<i>CMS Output dimensions</i>	<b>L4</b>
	Dimensioni uscita CMC	<i>CMC Output dimensions</i>	<b>L6</b>
	Dimensioni uscita CF	<i>CF Output dimensions</i>	<b>L8</b>
	Dimensioni uscita CFS	<i>CFS Output dimensions</i>	<b>L10</b>
	Dimensioni uscita CCPC	<i>CCPC Output dimensions</i>	<b>L12</b>
	Accessori	<i>Accessories</i>	<b>L14</b>
	Carichi in uscita	<i>Output loads</i>	<b>L15</b>
<b>M CHPL/CHPLB 30000</b>			<b>M1</b>
	Dati tecnici	<i>Technical data</i>	<b>M2</b>
	Dimensioni uscita CMS	<i>CMS Output dimensions</i>	<b>M4</b>
	Dimensioni uscita CMC	<i>CMC Output dimensions</i>	<b>M6</b>
	Dimensioni uscita CF	<i>CF Output dimensions</i>	<b>M8</b>
	Dimensioni uscita CFS	<i>CFS Output dimensions</i>	<b>M10</b>
	Dimensioni uscita CCPC	<i>CCPC Output dimensions</i>	<b>M12</b>
	Accessori	<i>Accessories</i>	<b>M14</b>
	Carichi in uscita	<i>Output loads</i>	<b>M15</b>
<b>N CHPL/CHPLB 35000</b>			<b>N1</b>
	Dati tecnici	<i>Technical data</i>	<b>N2</b>
	Dimensioni uscita CMS	<i>CMS Output dimensions</i>	<b>N4</b>
	Dimensioni uscita CMC	<i>CMC Output dimensions</i>	<b>N6</b>
	Dimensioni uscita CF	<i>CF Output dimensions</i>	<b>N8</b>
	Dimensioni uscita CFS	<i>CFS Output dimensions</i>	<b>N10</b>
	Dimensioni uscita CCPC	<i>CCPC Output dimensions</i>	<b>N12</b>
	Accessori	<i>Accessories</i>	<b>N14</b>
	Carichi in uscita	<i>Output loads</i>	<b>N15</b>
<b>P Appendice</b>	<b>Appendix</b>		<b>P1</b>
	Motori elettrici	<i>Electric motors</i>	<b>P1</b>
	Predisposizioni per riduttori a vite senza fine	<i>Worm gearbox connections</i>	<b>P6</b>
	Alberi maschio in entrata	<i>Male input shafts</i>	<b>P7</b>
	Predisposizioni per motori idraulici	<i>Hydraulic motors connections</i>	<b>P8</b>
	Freni idraulici	<i>Hydraulic brakes</i>	<b>P10</b>
	Condizioni generali di vendita	<i>General sales conditions</i>	<b>P11</b>







## INTRODUZIONE

Ingombri ridotti, elevata affidabilità e semplicità costruttiva sono tra le caratteristiche dei nuovi riduttori epicicloidali CHIARAVALLI.

Altro grande vantaggio è l'elevata modularità di configurazione che permette di assemblare in ingresso motori elettrici, idraulici, vite senza fine (serie CHM CHIARAVALLI) oppure alberi maschio cilindrici.

Diverse configurazioni di alberi e flange in uscita permettono l'utilizzo di questi riduttori in parecchie applicazioni industriali.

Disponibili nella versione lineare (CHPL) o in quella angolare (CHPLB), i riduttori epicicloidali della serie CHIARAVALLI comprendono 11 grandezze con coppie trasmissibili che vanno da 100 daNm a 3500 daNm e rapporti di riduzione da 3.55:1 sino a 3422:1 e oltre per riduttori con più di 4 stadi di riduzione (ordinabili a richiesta).

I riduttori CHIARAVALLI sono normalmente forniti con fondo preparatorio per la verniciatura.

## INTRODUCTION

*High reliability , compact volumes and easy construction are among the main characteristics of new CHIARAVALLI planetary gearboxes.*

*As one of the main advantages , our planetary gearboxes can be easily assembled with electric and hydraulic motors, worm gearboxes (CHM series) and input shafts.*

*Furthermore , they can be assembled with different output flanges or shafts, all these characteristics make them suitable for several industrial applications.*

*CHIARAVALLI planetary gear boxes are available in linear version (CHPL) and angular one (CHPLB). Our range covers 11 transmission sizes, from 100 daNm up to 3500 daNm , rate reductions from 3.55:1 to 3422:1 and more with four reduction stages (these available upon request).*

*CHIARAVALLI planetary gearboxes are available at anti rusted treated blank surface ready to be painted.*



# RIDUTTORI EPICICLOIDALI PLANETARY GEARBOX

## DESIGNAZIONE

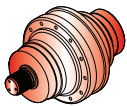
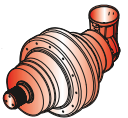
Tipo riduttore / Gear unit type	
CHPL 	Riduttori lineari Inline gear unit
CHPLB 	Riduttori angolari Bevel gear unit

Grandezza riduttore / Gear unit size
1000 - 1600 - 2500 - 5000 - 7000 - 10000 16000 - 18000 - 25000 - 30000 - 35000

Numero stadi / Stages number
1 - 2 - 3 - 4 (altri numeri di stadi disponibili a richiesta other reduction stages number on request)

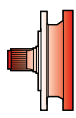
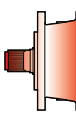
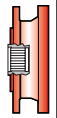
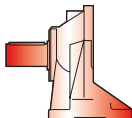
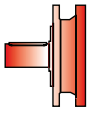
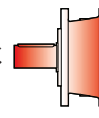
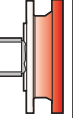

Tipo di uscita / Output type				
CMS 	CPS 	CF 	CCPC 	
CMC 	CPC 	CFS 		

Rapporto di riduzione / Reduction ratio
$i$ (vedere scheda tecnica del riduttore see technical sheets of gear unit)

### Esempio designazione / Example of designation:

1)	CHPL 7002 CPS 42.1 IEC90 B5 CHYZ CHFF
2)	CHPL 7002 CPS 42.1 CM42 B5 CHYZ CHFF
3)	CHPL 7002 CPS 42.1 H.2074.013.018 B5 CHYZ CHFF
4)	CHPL 7002 CPS 42.1 CHM63 20 90B14 C1 CHYZ CHFF

1) Riduttore epicicloidale in linea CHPL, taglia 7000 a 2 stadi, uscita tipo CPS e rapporto di riduzione  $i=42.1$ , in ingresso predisposizione per attacco motore elettrico IEC90. Posizione di montaggio dell'intero gruppo B5 e con accessori in uscita CHYZ e CHFF.  
In line CHPL planetary gearbox, size 7000 with 2 stages, output flange CPS ratio  $i=42.1$  and motor mounting flange for electrical motor IEC90. Mounting position B5 with output accessories CHYZ and CHFF.

2) Riduttore epicicloidale in linea CHPL, taglia 7000 a 2 stadi, uscita tipo CPS e rapporto di riduzione  $i=42.1$ , in ingresso albero maschio CM42. Posizione di montaggio dell'intero gruppo B5 e con accessori in uscita CHYZ e CHFF.  
In line CHPL planetary gearbox, size 7000 with 2 stages, output flange CPS ratio  $i=42.1$  and male shaft CM42. Mounting position B5 with output accessories CHYZ and CHFF.

3) Riduttore epicicloidale in linea CHPL, taglia 7000 a 2 stadi, uscita tipo CPS e rapporto di riduzione  $i=42.1$ , in ingresso predisposizione per montaggio motore idraulico cod.2074.013.018. SAUER-DANFOSS. Posizione di montaggio dell'intero gruppo B5 e con accessori in uscita CHYZ e CHFF.  
In line CHPL planetary gearbox, size 7000 with 2 stages, output flange CPS ratio  $i=42.1$  and motor mounting flange for hydraulic motor code 2074.013.018 SAUDER DANFOS. Mounting position B5 with output accessories CHYZ and CHFF.

4) Riduttore epicicloidale in linea CHPL, taglia 7000 a 2 stadi, uscita tipo CPS e rapporto di riduzione  $i=42.1$ , in ingresso riduttore VSF CHM63 con  $i_{VSF}=20$  e flangia motore 90B14. Posizione di montaggio dell'intero gruppo C1 e con accessori in uscita CHYZ e CHFF.  
In line CHPL planetary gearbox, size 7000 at 2 stages, output flange CPS ratio  $i=42.1$ , input reducer VSF CHM63  $i_{VSF}=20$  and motor mounting flange 90B14. Mounting position C1 with output accessories CHYZ and CHFF.

## DESIGNATION

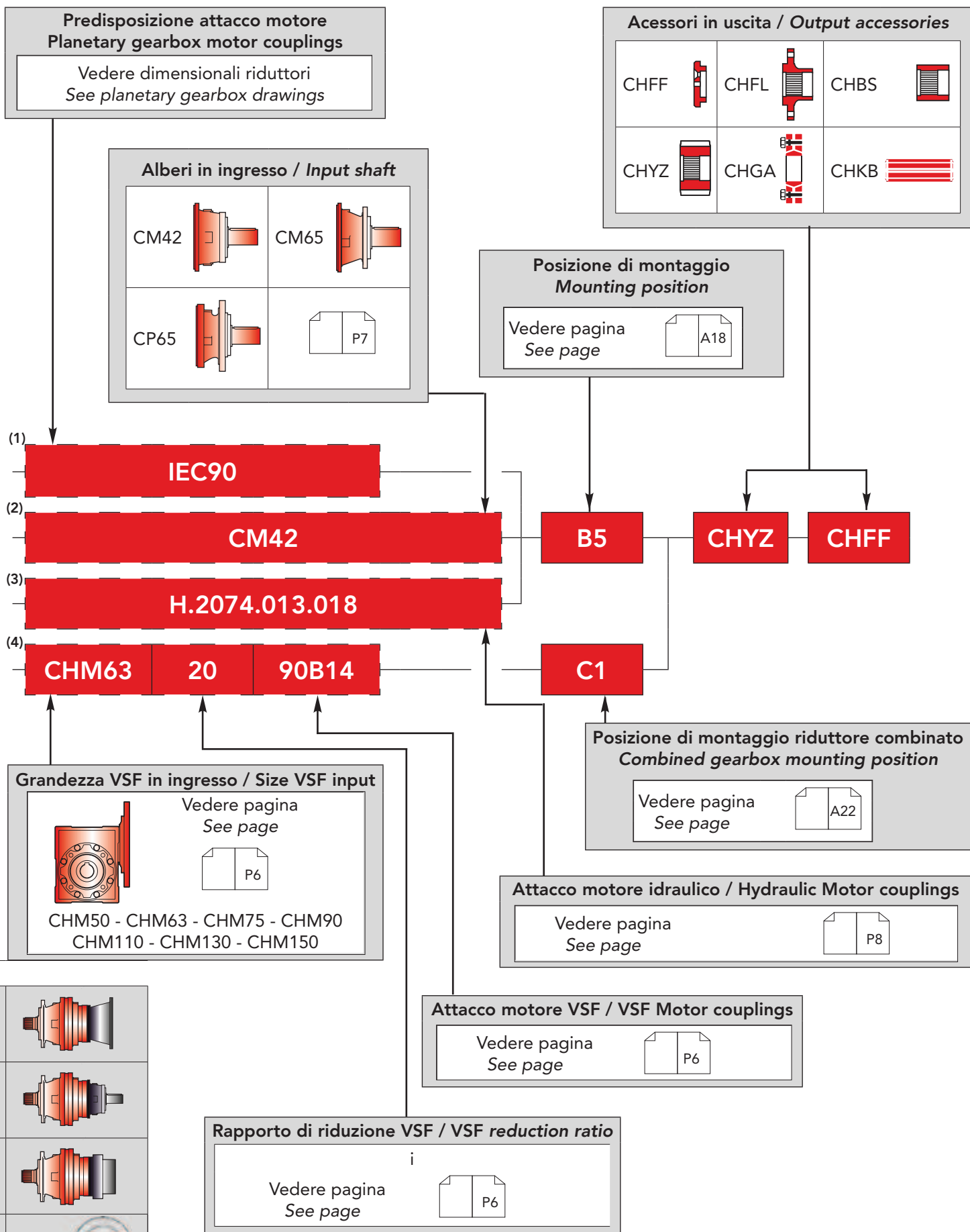



# RIDUTTORI EPICICLOIDALI PLANETARY GEARBOX



IEC Motor

CHM  
gearbox

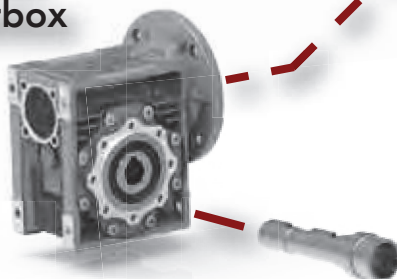

Hydraulic Motor



CP65



CHM  
flange

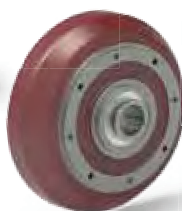

IEC Motor  
flange



Hydraulic Motor  
flange

Input



CCPC

# RIDUTTORI EPICICLOIDALI PLANETARY GEARBOX

A5

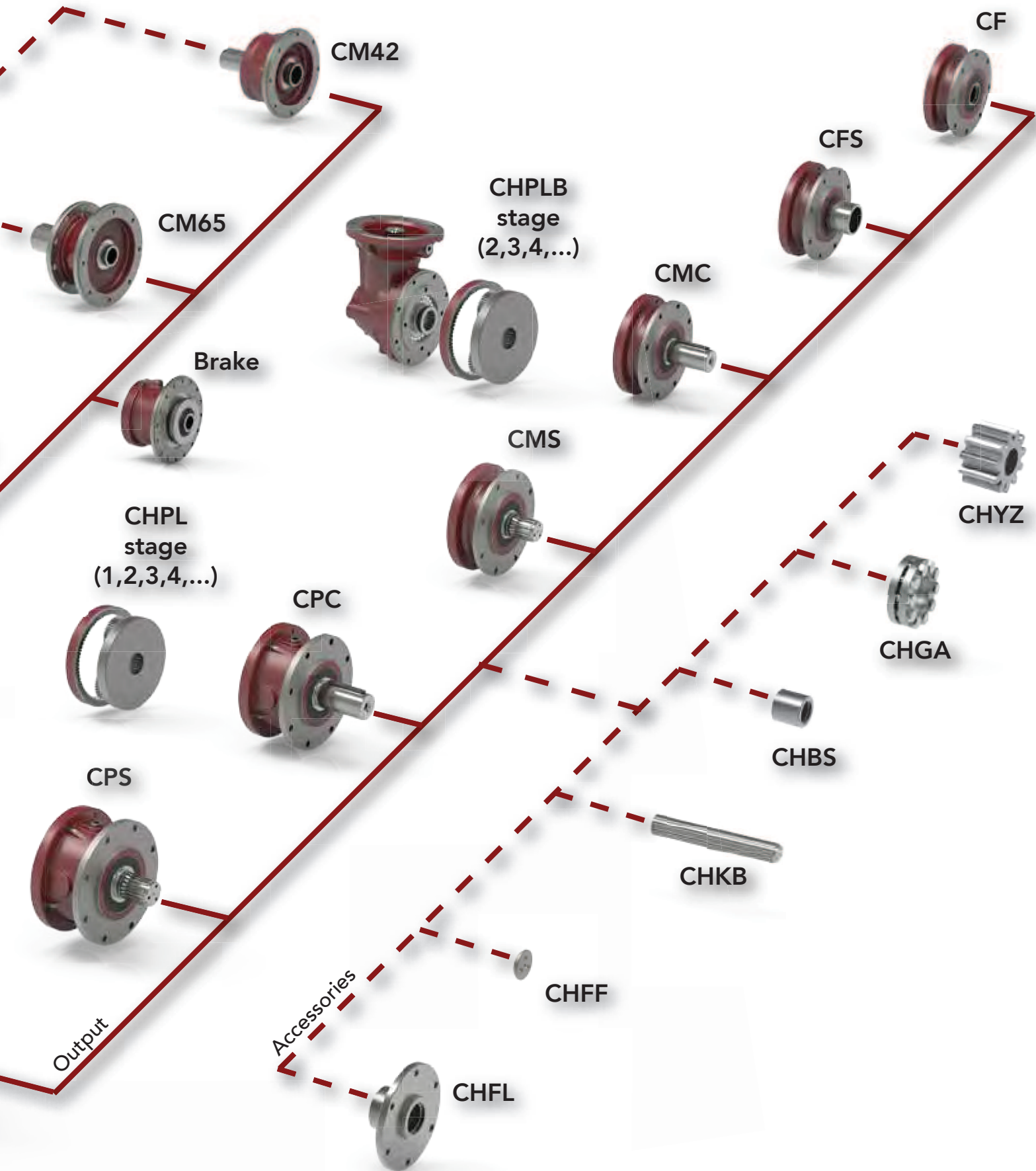



### CARATTERISTICHE TECNICHE

### TECHNICAL FEATURES

Al fine di utilizzare al meglio il presente catalogo come strumento professionale, vengono di seguito riportate le definizioni dei parametri caratteristici che saranno utilizzati:

*Here we are going to describe the characteristics and information necessary in order to use this catalogue in the most suitable way for any kind of final usage of our gear units in any market or professional fields:*

#### Rapporto di trasmissione

#### Reduction ratio

$i$

Indica il rapporto tra la velocità di rotazione in ingresso  $n_1$  e la velocità di rotazione  $n_2$  ottenuta in uscita dal gruppo riduttore.

*Provide the ratio between input rotation speed  $n_1$  and the output one  $n_2$  in our planetary gearboxes.*

#### Velocità massima in entrata

#### Maximum input speed

$n_{1max}$  [rpm]

Indica la massima velocità di rotazione consentita in ingresso al riduttore, considerando il funzionamento intermittente e non continuo del gruppo.

*This indicates the maximum input speed rotation allowed, considering a non-continuous use.*

Per applicazioni ove richiesto un funzionamento continuo del riduttore si prega di contattare il Servizio Tecnico CHIARAVALLI.

*Please contact CHIARAVALLI Technical dept. in case of continuous duty.*

#### Coppia nominale in uscita

#### Nominal output torque

$T_{2n}$  [daNm]

Indica la coppia trasmessa dal riduttore calcolata secondo i limiti della norma internazionale ISO 6336 in condizioni di  $F_s=1$ .

*This indicates the output torque values calculated according international ISO 6336 in  $F_s=1$  conditions*

#### Potenza nominale in ingresso

#### Input nominal power

$P_{1n}$  [kW]

Indica la potenza meccanica installabile sul riduttore secondo i limiti della norma internazionale ISO 6336. Valori riferiti a 1400 rpm  $F_s=1$ .

*This indicates the mechanical power assembling on our planetary gear boxes according international ISO 6336. Ref. values to 1400 rpm  $F_s=1$*

#### Rendimento

#### Efficiency

$\mu$  [%]

Indica il rendimento del riduttore tenendo conto delle perdite energetiche che si hanno durante il suo funzionamento.

*Give the value of the reducer efficiency considering the energy losses due to its normal usage.*

Mediamente il rendimento dei riduttori epicicloidali lineari (CHPL) è dello 0.97 - 0.98 % per stadio di riduzione; è leggermente inferiore nel caso di stadi di riduzione angolari (CHPLB).

*CHPL efficiency of our planetary gearboxes is about 0.97 - 0.98% for every reduction stage, while on CHPLB is a little less.*

Questo valore viene influenzato anche da altri fattori come l'alta velocità, la coppia, il rapporto di riduzione e la lubrificazione.

*Note these values may be influenced by several factors as high speed, the torque, the ratio and the lubrication.*



## CARATTERISTICHE TECNICHE

## TECHNICAL FEATURES

### Temperatura di funzionamento

### Usage temperature

$t$  [°C]

La temperatura dell'olio deve essere compresa tra -15°e +90°C.

Per temperature di funzionamento al di fuori di questo intervallo si consigliano tenute in materiali specifici e oli adeguati fornibili su richiesta.

Contattare il Servizio Tecnico CHIARAVALLI.

*Oil temperature must be among -15° and +90°C.*

*For any different temperature usage, we warmly recommend particular/specific oil seals and oils available under request. Please contact CHIARAVALLI Technical dept. for any info you might need.*

### Potenza termica

### Thermal power rating

$P_t$  [kW]

Indica la massima potenza dissipabile termicamente dal riduttore affinché la temperatura dell'olio e delle sue tenute rimanga entro i limiti consentiti.

Tale potenza si intende come dissipabile per convezione naturale dal corpo del riduttore stesso nell'ambiente in cui esso lavora e con lubrificazione interna a sbattimento.

I valori definiti per le potenze termiche, vengono considerati in condizioni di:

- Temperatura massima olio 90°C
- Olio ISO VG 150
- Temperatura ambiente 20°C.
- Posizione di montaggio orizzontale
- Servizio continuo
- $n_1=1400$  rpm

Per via della loro geometria i riduttori con uscita CCPC (uscita con piedi, fino alla taglia 16000), possono sopportare un incremento della potenza termica dal 10 al 15%.

Nel caso in cui la potenza installata superi quella termica sarà necessario l'utilizzo di un sistema di raffreddamento ausiliario in grado di dissipare la potenza termica in eccesso.

Contattare il Servizio Tecnico CHIARAVALLI.

*Indication of the maximum power that can be dissipated by the gearbox keeping oil and oil seals under the allowed limits.*

*This power can be dissipated for natural convection from the housing gearbox to the ambience with normal turbulence lubrication.*

*The values here described of thermic power must be consider according:*

- Oil max temperature 90°C
- Oil ISO VG 150
- Outside temperature 20°C
- Horizontal mounting position
- Continuous duty
- $n_1=1400$  rpm

*Due to their geometry CCPC reducers (foot mounted up to size 16000) allow a thermal power increase of about 10 to 15%.*

*In case the installed power overcomes the thermal one, an external cooled system is necessary in order to dissipate the extra heat.*

*Please contact CHIARAVALLI Technical dept. for any info you might need.*



## CARATTERISTICHE TECNICHE

## TECHNICAL FEATURES

### Fattore di servizio

### Service Factor

#### F<sub>s</sub>

Indica il coefficiente di moltiplicazione della coppia o potenza in funzione delle condizioni di lavoro (carichi, avviamenti, ore di funzionamento, tipologia di motorizzazione e tipologia di applicazione).

*This is a multiplication coefficient that indicates how much the torque and the power may be increased according any different working conditions.*

Il fattore di servizio **F<sub>s</sub>** può considerarsi influenzato principalmente da tre fattori:

*Service Factor **F<sub>s</sub>** may be influence by mainly 3 factors:*

- tipo di carico: U - M - H
- ore di lavoro giornaliere: h/day
- frequenza oraria avviamenti: na/h

- *Type of load: U - M - H*
- *Daily working hours: h/day*
- *Hour frequency starter: na/h*

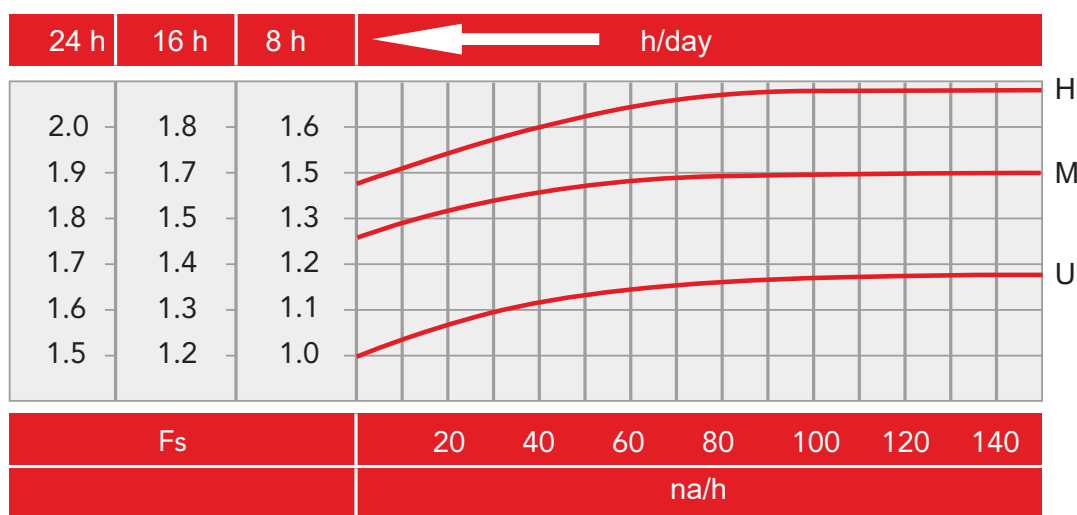

U: Trasportatori a nastro per pesi leggeri  
Pompe centrifughe  
Elevatori  
Imbottigliatrici

*U: Conveyor belts for light weights  
Centrifugal pumps  
Lifts  
Bottling machines*

M: Trasportatori per materiali pesanti  
Macchine imballaggio  
Pompe a ingranaggi

*M: Conveyor belts for heavy weights  
Packing machines  
Gear pumps*

H: Mescolatori  
Elevatori a tazze  
Macchine utensili  
Macchine per laterizi  
Vibratori

*H: Mixers  
Bucket elevators  
Tooling machines  
Machinery for bricks  
Vibrators*





## CARATTERISTICHE TECNICHE

## TECHNICAL FEATURES

### Scelta del riduttore

### Planetary gearboxes selection

Il riduttore di velocità opera tra la parte motore, adibita alla generazione della coppia motrice, e la parte macchina che genera coppia resistente sul riduttore.

Per selezionare correttamente il riduttore occorrerà conoscere tipologie e caratteristiche del motore installato, potenza erogata, coppia erogata e velocità di funzionamento.

Per quanto concerne il lato macchina, occorrerà conoscere la tipologia di servizio, potenza/coppia assorbita, velocità di rotazione e ciclo di lavoro.

Con tali informazioni si vanno a definire:

- Coppia di lavoro  $T$  [daNm]
- Potenza installata  $P$  [kW]
- Rapporto di trasmissione  $i$
- Carichi sull'albero in uscita e in entrata al riduttore  $F_r$ ;  $F_a$  [N]

In seguito si andranno a verificare i parametri che caratterizzano il riduttore

- Coppia di lavoro, tenendo conto del fattore di servizio  $F_s$   $T \cdot F_s \leq T_{2n}$
- Potenza installata, tenendo conto del fattore di servizio  $F_s$   $P \cdot F_s \leq P_{1n}$
- Velocità in ingresso al riduttore  $n_1 < n_{1max}$
- Potenza da trasmettere  $< P_t$  (se in servizio continuo)
- Carichi sull'albero in uscita e in entrata al riduttore  $F_r$ ;  $F_a$  [N]
- Condizioni di lubrificazione e temperatura ambiente

*The unit works between the input motor part, that creates the torque, and the final equipment.*

*To select the more suitable gearbox in any final usage, it is necessary to have the type and the characteristics of the mounted motor, the power, the torque and the working speed.*

*Concerning the driven machine it is necessary to know the type of operation, power and torque requested, speed and duty.*

*According with these informations we define together:*

- Working torque  $T$  [daNm]
- Mounted power  $P$  [kW]
- Ratio  $i$
- Radial and axial loads on input and output shafts  $F_r$ ;  $F_a$  [N]

*Consequently the gearbox parameters will be defined*

- Working torque considering  $F_s$  where  $T \cdot F_s \leq T_{2n}$
- Mounted power considering  $F_s$  where  $P \cdot F_s \leq P_{1n}$
- Input speed  $n_1 < n_{1max}$
- Requested Power  $< P_t$  (for continuous duty)
- Radial and axial loads on input and output shafts  $F_r$ ;  $F_a$  [N]
- Lubrication and room temperature



## INSTALLAZIONE E MANUTENZIONE

## INSTALLATION AND MAINTENANCE

### Installazione e manutenzione

### Run-in and maintenance

Per ottenere le migliori prestazioni dal riduttore, si consiglia di provvedere ad un adeguato rodaggio dello stesso incrementando la potenza gradualmente nelle prime ore di funzionamento.

In questa fase un aumento delle temperature è da considerarsi nella norma. In caso di funzionamento difettoso, rumorosità, perdite olio etc. arrestare immediatamente il riduttore e, dove possibile, rimuovere la causa e contattare il Servizio Tecnico CHIARAVALLI.

Prima e durante l'installazione effettuare i seguenti controlli:

- i dati riportati sulla targhetta identificativa devono corrispondere al riduttore ordinato.
- Il livello dell'olio dovrà corrispondere alla quantità prevista per la posizione di montaggio richiesta (vedi paragrafo "Lubrificazione").
- Il fissaggio del riduttore deve avvenire su superfici piane e sufficientemente rigide in modo da evitare qualsiasi vibrazione.
- Il riduttore e l'asse della macchina da movimentare devono essere in perfetto allineamento.
- In caso si prevedano urti, sovraccarichi o blocchi della macchina il cliente dovrà provvedere all'installazione di limitatori, giunti, salvamotori etc.
- Gli accoppiamenti con pignoni, giunti, pulegge ed altri organi devono essere fatti previa pulizia delle parti ed evitando urti nel montaggio poiché questo potrebbe danneggiare i cuscinetti ed altre parti interne.
- Nel caso il motore sia di fornitura del cliente questi dovrà accertarsi che le tolleranze di flangia ed albero corrispondano ad una classe "normale", i nostri motori rispondono a questa esigenza.
- Verificare che le viti di fissaggio del riduttore e dei relativi accessori siano correttamente serrate.
- Adottare gli opportuni accorgimenti per proteggere i gruppi da eventuali agenti atmosferici aggressivi.
- Dove previsto proteggere le parti rotanti da possibili contatti con gli operatori.
- Nel caso i riduttori vengano verniciati proteggere gli anelli di tenuta ed i piani lavorati.

Nel caso di applicazioni in cui sia richiesto l'utilizzo di motori con massa superiore ai 100 kg, si consiglia di contattare il Servizio Tecnico CHIARAVALLI.

Nel caso di lunga conservazione a magazzino, superiore ai tre mesi, si consiglia di proteggere alberi e piani lavorati con antiossidanti e di ingrassare gli anelli di tenuta.

*In order to achieve the best gearbox performances, during the run-in, we warmly recommend to increase the power step by step and strictly control the temperature.*

*During this period an increase of temperature must be considered normal.*

*In any case of defected drive, noise, oil losses please immediately stop the gear box unit, if possible remove the problem and contact CHIARAVALLI Technical department.*

*Before and during the first run-in please check:*

- *The data shown on the identification nameplate must correspond to the gearbox ordered.*
- *The oil level depends on the mounting position requested (see section LUBRICATION).*
- *The gearbox must be on a flat surface that is sufficiently rigid in order to avoid any vibration.*
- *The gearbox and the axis of the machine to be driven must be perfectly aligned.*
- *In the event that knocks, overloading or blockage of the machine are foreseen, the customer must install a limit device, couplings overload cut-out etc.*
- *Coupling with pinions, joints, pulleys and other parts must be done after the parts have been cleaned and knocks should be avoided while assembling as they could damage the bearings and other internal parts.*
- *In the event that the motor is supplied by the customer, he must check that the flange and shaft tolerances correspond to a "normal" class; our motors satisfy this requirement.*
- *Verify that the fixing screws for the gear and the related accessories are correctly tightened.*
- *Take suitable measures to protect the groups from any aggressive atmospheric agents.*
- *Where foreseen, protect rotating parts from any possible contact with the operators.*
- *If the gearboxes are painted, protect the oil seals and the machined surface.*

*As the application requires the assembling of a motor over 100 kg, we suggest to contact CHIARAVALLI Technical department for further information.*

*In case of long storage in warehouse, for example more than 3 months, please protect the shafts and the machined surfaces using antioxidants and grease the oil seals.*



## INSTALLAZIONE E MANUTENZIONE

## INSTALLATION AND MAINTENANCE

### Gruppi con fissaggio a flangia/piedi

### Unit with flange/feet clamping

#### Uscite maschio tipo CMS - CMC - CPS - CPC

E' necessario utilizzare sempre tutti i centraggi previsti su gli alberi scanalati, specie per applicazioni in cui sono adottati pignoni dentati.

Per le uscite maschio si consiglia di adottare entrambi i centraggi delle flange d'attacco, nel caso in cui i carichi radiali superino del 50% i valori indicati nei relativi grafici (vedere singole schede grandezza riduttore).

Nel caso di applicazioni gravose con forti sollecitazioni sia sull'albero in ingresso che sull'albero in uscita è consigliabile contattare il Servizio Tecnico CHIARAVALLI.

#### Uscite maschio con piedi CCPC

Per le uscite con piedi è necessario controllare i piani della struttura d'appoggio in modo da creare un perfetto allineamento tra il riduttore e l'albero da movimentare. In caso di difficoltà si consiglia di effettuare il collegamento tramite un giunto elastico. Una volta installato il riduttore verificare che non ci siano vibrazioni anomale.

#### Uscite femmina tipo CF

Per le uscite femmina scanalate è necessario verificare in modo accurato la coassialità/ortogonalità con l'albero di trasmissione. Per via della loro struttura queste tipologie di uscite non sono adatte a sopportare carichi radiali.

#### Uscite con calettatore a montaggio pendolare CFS

Tale uscita necessita l'adozione di un opportuno calettatore (fornibile su richiesta) per collegare l'albero cavo del riduttore all'albero maschio della macchina.

Per tale accoppiamento sgrassare accuratamente le superfici interessate, procedere all'avvitamento delle viti del calettatore in modo graduale e una alla volta.

E' importante verificare che l'albero maschio da calettare rispetti le dimensioni e le tolleranze riportate nelle relative pagine dimensionali.

Per l'installazione dell'uscita CFS è possibile utilizzare il braccio di reazione come indicato nelle relative schede tecniche; si consiglia l'utilizzo di bracci di reazione con elementi antivibranti.

Nel caso di applicazioni in cui sia richiesto l'utilizzo di motorizzazioni particolarmente pesanti o si utilizzino cinghie sul lato entrata, si consiglia di contattare il Servizio Tecnico CHIARAVALLI.

#### Male output CMS - CMC - CPS - CPC

*When tooth pinions are mounted, the spigots on the splined output shafts must be used.*

*For these kind of units, when the radial loads are 50% higher than values indicate in the tables (please check tables in the following pages) , we warmly suggest to use both spigots of the flanges.*

*In case of heavy applications, contact CHIARAVALLI Technical department for further information.*

#### Male output with feet CCPC

*For these gearboxes please check the properly aligned between the gear unit and the operating shaft, use a flexible coupling in case of difficulties, finally please check the vibrations.*

#### Female output CF

*Carefully check the gearbox concentricity and perpendicularity, this must be in line with the axis of the driven shaft. Due to this characteristic CF type is not suitable for radial load.*

#### Shaft mounted output with locking element type CFS

*For this type it is necessary to use a suitable locking element (available on request) to connect the gearbox hollow shaft with the operating shaft. In this case properly degrease the internal surface, then proceed tightening the locking screws in a gradual, uniform and continuous sequence one by one. Check the tolerances and the dimensions provided on each drawing of the operating shaft.*

*CFS output can be mounted with a torque arm as indicate on the technical tables, we suggest using torque arms with antivibration rubber elements.*

*In case of heavy applications or with belts on the input side, please contact CHIARAVALLI Technical department for further information.*



### LUBRIFICAZIONE

### LUBRICATION

La lubrificazione degli organi interni è indispensabile per garantire il buon funzionamento e la corretta durata del riduttore CHIARAVALLI.

Si consiglia pertanto di effettuare le seguenti verifiche:

- **POSIZIONE ORIZZONTALE:**  
indipendentemente dalla versione lineare o angolare è importante verificare che l'olio raggiunga la mezziera del riduttore.
- **POSIZIONE VERTICALE:**  
in questa posizione è molto importante verificare che il cuscinetto e l'anello di tenuta che si trovano nel punto superiore del gruppo siano costantemente a contatto con l'olio.  
E' consigliato installare il vaso di espansione (fornibile su richiesta) in modo da prevenire eventuali espansioni dell'olio con l'aumentare della temperatura. In caso di impossibilità di installazione del vaso consigliamo l'utilizzo di appositi raccordi e prolunghe in modo da garantire il corretto livello dell'olio (verificare sempre l'assenza di bolle d'aria in fase di riempimento d'olio).

Accertarsi che il riduttore abbia i tappi montati nei punti coerenti alla relativa posizione di montaggio come successivamente indicato.

Durante il funzionamento la superficie esterna del riduttore deve restare sotto i 90°C.

In caso di applicazioni con elevate temperature contattare il Servizio Tecnico CHIARAVALLI.

*In order to make the CHIARAVALLI planetary gearboxes run efficiently we recommend a correct lubrication following these simple suggestions:*

- **HORIZONTAL POSITION:**  
*no matter if linear or angular version, the oil must reach the half of the gearbox.*
- **VERTICAL POSITION:**  
*In this position the bearings and the oil seals must be continuously in contact with oil.  
We suggest to use an expansion tank (available on request) to avoid any oil spread at the increase of temperature. In some cases the assembling of the tank is not allowed, so we suggest to use suitable extensions and pipes to guarantee the correct oil level (please check any possible air bubble while filling the oil).*

*Check the correct position of the plugs according the assembling position as we indicate beyond.*

*Maximum external surface gearbox temperature must be under 90°C.*

*Please contact CHIARAVALLI Technical department for any different case.*

#### Cambio olio

#### Oil changes

Si consiglia di effettuare il primo cambio dell'olio dopo 100 h di funzionamento.

Per quelli successivi considerare circa 2000 h di utilizzo o comunque almeno una volta all'anno.

Durante la vita del riduttore, controllare visivamente che non vi siano perdite o trafiletti di olio.

Se l'olio scende al di sotto del livello minimo, effettuare un rabbocco con il medesimo olio precedentemente utilizzato.

E' importante non mischiare lubrificanti con caratteristiche differenti.

E' opportuno eseguire il cambio dell'olio quando il riduttore è ancora caldo in modo da evitare possibili depositi e sedimenti solidi all'interno del corpo del riduttore stesso.

Si consiglia inoltre, una volta svuotato il riduttore dall'olio esausto, di effettuare un lavaggio dell'interno con un apposito detergente indicato dal fornitore del lubrificante che si andrà ad adottare.

*We suggest the first change after 100h of work, then please consider 2000 running hours or at least once per year.*

*During the gearbox life periodically check the oil level and possible oil leakages.*

*Please fill extra oil in case of lack or under minimum level without changing the type of oil.*

*Do never mix the type of oil.*

*To avoid sediment change the oil when the reducer is still warm, clean the internal parts using only the correct and recommend detergent after empty the reducer.*



## LUBRIFICAZIONE

## LUBRICATION

### Vaso di espansione

### Expansion tank

Per i gruppi montati in posizione verticale (lineari CHPL o angolari CHPLB) e in posizione orizzontale con la coppia conica rivolta verso l'alto, si consiglia l'utilizzo del vaso di espansione. Il vaso va posizionato al di sopra del punto più alto del riduttore ed ha il compito di contenere eventuali espansioni dell'olio all'aumentare della temperatura e garantire un rabbocco sicuro. Tale accessorio può essere fornito su richiesta.

Use the expansion tank for the CHPL and CHPLB groups mounting in vertical position and in horizontal position when the bevel gear is upside assembled. Put the tank on the gearbox higher point to control any oil spread due to temperature increasing and fill the reducer properly. This item is available on request.

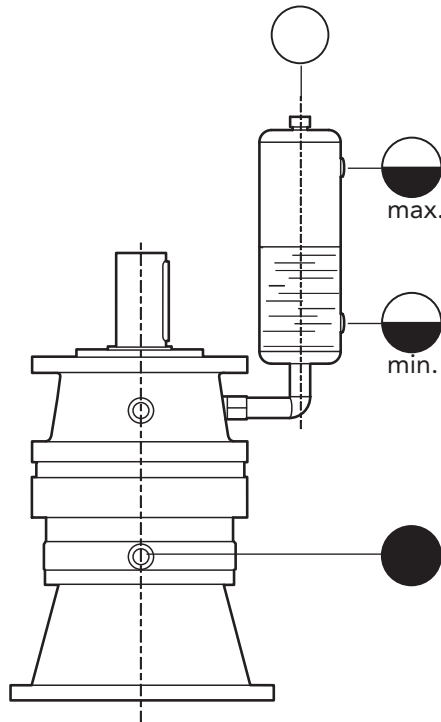

Riduttore assiale verticale con ingresso inferiore.  
Axial gearbox vertical position with lower input.

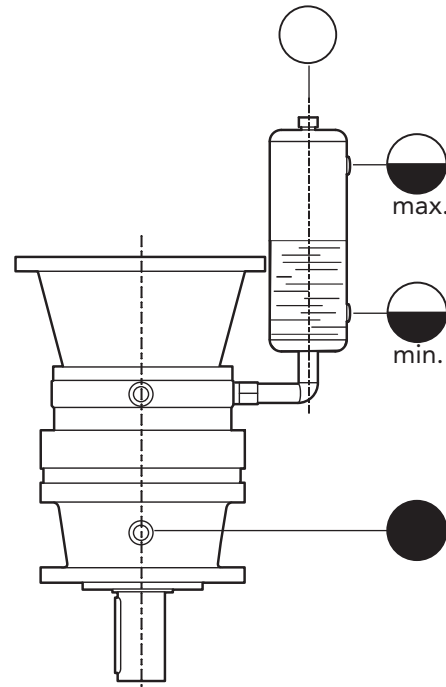

Riduttore assiale verticale con ingresso superiore.  
Axial gearbox vertical position with upper input.

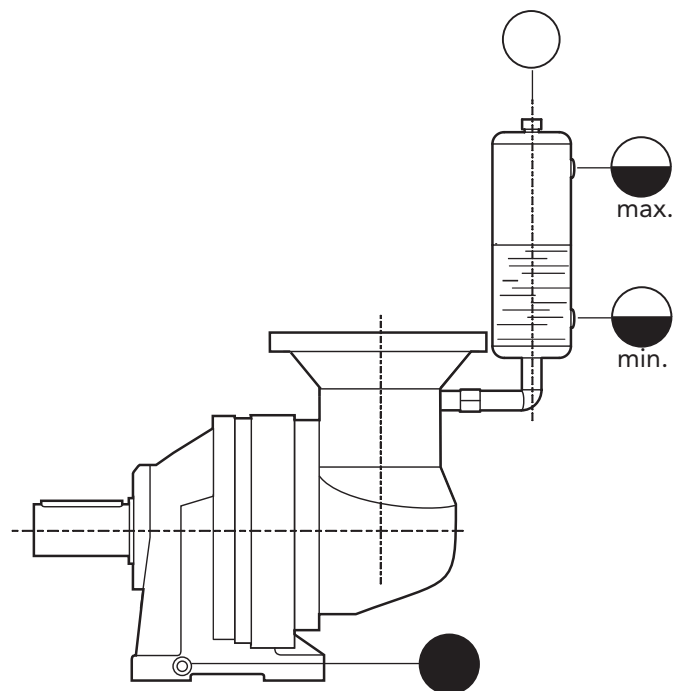

Riduttore angolare orizzontale con ingresso superiore.  
Bevel gearbox horizontal position with upper input.

 Tappo di carico/sfiato olio  
Oil filling/vent plug

 Tappo di livello olio  
Oil level plug

 Tappo di scarico olio  
(magnetico)  
Oil drain plug  
(magnetic)



## LUBRIFICAZIONE

## LUBRICATION

### Smaltimento olio esausto

In fase di smaltimento degli oli esausti, è obbligatorio usare tutte le cautele per non inquinare suolo, aria e acqua. L'olio esausto, non deve essere inquinato da altre sostanze estranee e deve obbligatoriamente essere smaltito in appositi centri autorizzati, il tutto nel rispetto delle normative vigenti.

### Lubrificante

CHIARAVALLI consiglia l'uso di oli per ingranaggi con additivi EP (elevate pressioni) ed antischiuma.

Per applicazioni ad elevate temperature, si consiglia l'utilizzo di oli sintetici a base polialfaolefina (PAO) o a base poliglicole (PG).

Nella tabella successiva suggeriamo alcuni oli idonei alla lubrificazione in funzione della temperatura d'utilizzo.

### Exhausted oil disposing

According the local environmental protection laws and regulations adopt precaution necessary to avoid to pollute ground, air and water. The exhausted oil must be not contaminated by any other substance and should be sent to specialised companies for recycling when possible.

### Lubricant

CHIARAVALLI technical dept. suggests the use of EP oil with additives and antifoam. In case of high temperature please use PAO synthetic or PG oils.

In the following table check some useful oils according the working temperature.

	Temperatura ambiente / Ambient temperature [°C]								
	Olio minerale Mineral Oil			Olio sintetico Polialfaolefina (PAO) Poly-alpha-Olefin Syntetic Oil (PAO)			Olio sintetico Poliglicoli (PG) Poly-glycol Syntetic Oil (PG)		
	-10 ÷ +30	+10 ÷ +45	+30 ÷ +60	-20 ÷ +60			-20 ÷ +60		
ISO 3448	ISO VG 150	ISO VG 220	ISO VG 320	ISO VG 150	ISO VG 220	ISO VG 320	ISO VG 150	ISO VG 220	ISO VG 320
 AGIP	Blasia 150	Blasia 220	Blasia 320	-	Blasia SX 220	Blasia SX 320	Blasia S 150	Blasia S 220	Blasia S 320
 ESSO	Spartan EP 150	Spartan EP 220	Spartan EP 320	Spartan S EP 150	Spartan S EP 220	Spartan S EP 320	Glycolube 150	Glycolube 220	Glycolube 320
 MOBIL	Mobilgear XMP 150	Mobilgear XMP 220	Mobilgear XMP 320	Mobilgear SHC XMP 150	Mobilgear SHC XMP 220	Mobilgear SHC XMP 320	Glygoyle 22	Glygoyle 30	Glygoyle HE 320
 SHELL	Omala S2G 150	Omala S2G 220	Omala S2G 320	Omala S4GX 150	Omala S4GX 220	Omala S4GX 320	Omala S4WE 150	Omala S4WE 220	Omala S4WE 320



La viscosità aumenta al diminuire della temperatura (diventa più denso) e diminuisce all'aumentare delle temperatura (diventa più fluido).  
The viscosity of the lubricant decrease as the temperature rises and increase as the temperature drops.



## LUBRIFICAZIONE

## LUBRICATION

### Quantità lubrificante

### Lubricant quantity











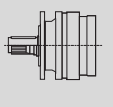
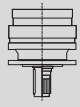
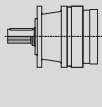
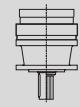
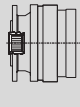
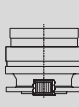

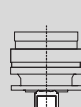
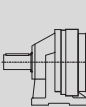
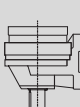
I quantitativi di olio di seguito riportati sono indicativi e soggetti a variazioni in funzione della configurazione del riduttore.

Indipendentemente dai quantitativi di seguito riportati, controllare sempre visivamente che l'olio raggiunga il livello corretto come precedentemente indicato.

The data in the table here below are indicative and may change according the gearbox mounting position.

Please always check the oil level following the previous suggestions.

### CHPL: riduttori assiali axial gearbox 1000 ÷ 10000

		Tipo di uscita / Output type									
		CMS - CMC		CPS - CPC		CF		CFS		CCPC	
											
											
		[1]	[1]	[1]	[1]	[1]	[1]	[1]	[1]	[1]	[1]
CHPL	1001	0.5	1.0	0.5	1.0	0.5	1.0	0.5	1.0	0.8	1.6
	1002	0.7	1.4	0.7	1.4	0.7	1.4	0.7	1.4	1.0	2.0
	1003	0.9	1.8	0.9	1.8	0.9	1.8	0.9	1.8	1.2	2.4
	1004	1.1	2.2	1.1	2.2	1.1	2.2	1.1	2.2	1.4	2.8
CHPL	1601	0.6	1.2	0.6	1.2	0.6	1.2	0.6	1.2	0.9	1.8
	1602	0.8	1.6	0.8	1.6	0.8	1.6	0.8	1.6	1.1	2.2
	1603	1.0	2.0	1.0	2.0	1.0	2.0	1.0	2.0	1.3	2.6
	1604	1.2	2.4	1.2	2.4	1.2	2.4	1.2	2.4	1.5	3.0
CHPL	2501	1.0	2.0	1.2	2.4	0.8	1.6	1.0	2.0	1.5	3.0
	2502	1.3	2.6	1.5	3.0	1.1	2.2	1.3	2.6	1.8	3.6
	2503	1.5	3.0	1.7	3.4	1.3	2.6	1.5	3.0	2.0	4.0
	2504	1.7	3.4	1.9	3.8	1.5	3.0	1.5	3.0	2.2	4.4
CHPL	5001	1.1	2.2	1.3	2.6	0.9	1.8	1.1	2.2	1.6	3.2
	5002	1.5	3.0	1.7	3.4	1.3	2.6	1.5	3.0	2.0	4.0
	5003	1.8	3.6	2.0	4.0	1.6	3.2	1.8	3.6	2.3	4.6
	5004	2.0	4.0	2.2	4.4	1.8	3.6	2.0	4.0	2.5	5.0
CHPL	7001	-	-	1.6	3.2	1.6	3.2	1.6	3.2	2.4	4.8
	7002	-	-	2.0	4.0	2.0	4.0	2.0	4.0	2.8	5.6
	7003	-	-	2.3	4.6	2.3	4.6	2.3	4.6	3.1	6.2
	7004	-	-	2.5	5.0	2.5	5.0	2.5	5.0	3.3	6.6
CHPL	10001	2.4	4.8	-	-	2.2	4.4	2.4	4.8	3.6	7.2
	10002	3.1	6.2	-	-	2.9	5.8	3.1	6.2	4.3	8.6
	10003	3.5	7.0	-	-	3.3	6.6	3.5	7.0	4.7	9.4
	10004	3.8	7.6	-	-	3.6	7.2	3.8	7.6	5.0	10.0























## LUBRIFICAZIONE

## LUBRIFICATION

Quantità lubrificante

Lubricant quantity

CHPL: riduttori assiali  
axial gearbox 16000 ÷ 35000

		Tipo di uscita / Output type									
		CMS - CMC		CPS - CPC		CF		CFS		CCPC	
											
											
		[1]	[1]	[1]	[1]	[1]	[1]	[1]	[1]	[1]	[1]
CHPL	16001	2.6	5.2	4.3	8.6	1.9	3.8	2.6	5.2	3.9	7.8
	16002	3.3	6.6	5.0	10.0	2.6	5.2	3.3	6.6	4.6	9.2
	16003	3.7	7.4	5.4	10.8	3.0	6.0	3.7	7.4	5.0	10.0
	16004	4.0	8.0	5.7	11.4	3.3	6.6	4.0	8.0	5.3	10.6
CHPL	18002	3.9	7.8	5.6	11.2	3.2	6.4	3.9	7.8	5.2	10.4
	18003	4.6	9.2	6.3	12.6	3.9	7.8	4.6	9.2	5.9	11.8
	18004	4.9	9.8	6.6	13.2	4.2	8.4	4.9	9.8	6.2	12.4
CHPL	25001	3.7	7.4	-	-	2.9	5.8	2.9	5.8	3.7	7.4
	25002	4.6	9.2	-	-	3.8	7.6	3.8	7.6	4.6	9.2
	25003	5.0	10.0	-	-	4.2	8.4	4.2	8.4	5.0	10.0
	25004	5.3	10.6	-	-	4.5	9.0	4.5	9.0	5.3	10.6
CHPL	30002	5.3	10.6	-	-	4.5	9.0	4.5	9.0	5.3	10.6
	30003	5.8	11.6	-	-	5.0	10.0	5.0	10.0	5.8	11.6
	30004	6.1	12.2	-	-	5.3	10.6	5.3	10.6	6.1	12.2
CHPL	35001	4.0	8.0	-	-	3.3	6.6	3.3	6.6	4.0	8.0
	35002	5.5	11.0	-	-	4.7	9.4	4.7	9.4	5.5	11.0
	35003	6.0	12.0	-	-	5.2	10.4	5.2	10.4	6.0	12.0
	35004	6.3	12.6	-	-	5.5	11.0	5.5	11.0	6.3	12.6















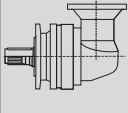

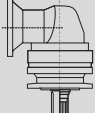

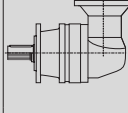

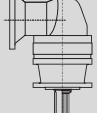

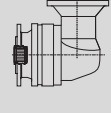

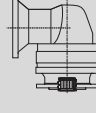
## LUBRIFICAZIONE

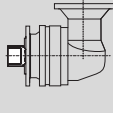
## LUBRIFICATION

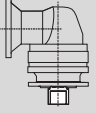
Quantità lubrificante

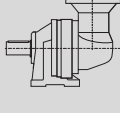
Lubricant quantity

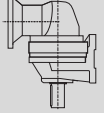
**CHPLB: riduttori angolari  
angular gearbox 1000 ÷ 35000**

		Tipo di uscita / Output type									
		CMS - CMC		CPS - CPC		CF		CFS		CCPC	
		  [1]	  [1]	  [1]	  [1]	  [1]	  [1]	  [1]	  [1]	  [1]	  [1]
CHPLB	1002	2	4	2	4	2.0	4.0	2.0	4.0	2.3	4.6
	1003	2.2	4.4	2.2	4.4	2.2	4.4	2.2	4.4	2.5	5.0
	1004	2.4	4.8	2.4	4.8	2.4	4.8	2.4	4.8	2.7	5.4
CHPLB	1602	2.1	4.2	2.1	4.2	2.1	4.2	2.1	4.2	2.4	4.8
	1603	2.3	4.6	2.3	4.6	2.3	4.6	2.3	4.6	2.6	5.2
	1604	2.5	5.0	2.5	5.0	2.5	5.0	2.5	5.0	2.8	5.6
CHPLB	2502	2.6	5.2	3.8	7.6	2.4	4.8	2.6	5.2	3.1	6.2
	2503	2.8	5.6	3.0	6.0	2.6	5.2	2.8	5.6	3.3	6.6
	2504	3.0	6.0	3.2	6.4	2.8	5.6	3.0	6.0	3.5	7.0
CHPLB	5002	3.1	6.2	3.3	6.6	2.9	5.8	3.1	6.2	3.6	7.2
	5003	3.2	6.4	3.4	6.8	3.3	6.6	3.2	6.4	3.7	7.4
	5004	3.3	6.6	3.5	7.0	3.1	6.2	3.3	6.6	3.8	7.6
CHPLB	7002	-	-	3.6	7.2	3.6	7.2	3.6	7.2	4.4	8.8
	7003	-	-	3.8	7.6	3.8	7.6	3.8	7.6	4.6	9.2
	7004	-	-	4.0	8.0	4.0	8.0	4.0	8.0	4.8	9.6
CHPLB	10002	4.4	8.8	-	-	4.2	8.4	4.4	8.8	5.6	11.2
	10003	5.1	10.2	-	-	4.9	9.8	5.1	10.2	6.3	12.6
	10004	6.5	13.0	-	-	5.5	11.0	6.5	13.0	7.7	15.4
CHPLB	16002	4.6	9.2	6.3	12.6	3.9	7.8	4.6	9.2	5.9	11.8
	16003	5.3	10.6	7.0	14.0	4.6	9.2	5.3	10.6	6.6	13.2
	16004	6.5	13.0	7.3	14.6	5.8	11.6	6.5	13.0	7.8	15.6
CHPLB	18002	5.6	11.2	7.3	14.6	4.9	9.8	5.6	11.2	6.9	13.8
	18003	5.9	11.8	7.6	15.2	5.2	10.4	5.9	11.8	7.2	14.4
	18004	6.6	13.2	8.3	16.6	5.9	11.8	6.6	13.2	7.9	15.8
CHPLB	25002	9.1	18.2	-	-	8.3	16.6	8.3	16.6	9.1	18.2
	25003	6.6	13.2	-	-	5.8	11.6	5.8	11.6	6.6	13.2
	25004	7.0	14.0	-	-	6.2	12.4	6.2	12.4	7.0	14.0
CHPLB	30003	10.2	20.4	-	-	9.4	18.8	9.4	18.8	10.2	20.4
	30004	8.2	16.4	-	-	7.0	14.0	7.0	14.0	8.2	16.4
CHPLB	35002	6.7	13.4	-	-	5.8	11.6	5.8	11.6	6.7	13.4
	35003	10.2	20.4	-	-	9.4	18.8	9.4	18.8	10.2	20.4
	35004	8.2	16.4	-	-	7.0	14.0	7.0	14.0	8.2	16.4



## POSIZIONI DI MONTAGGIO

## MOUNTING POSITIONS

CMS CMC			
	B5 (A)	V1 (B)	V3 (C)
	CPS CPC		
B5 (A)		V1 (B)	V3 (C)
CF			
	B5 (A)	V1 (B)	V3 (C)
	CFS		
B5 (A)		V1 (B)	V3 (C)
CCPC			
	B3 (A)	V2 (B)	V4 (C)
B8 (D)	B6 (E)	B7 (F)	

Tappo di carico/sfiato olio  
Oil filling/vent plug

Tappo di livello olio  
Oil level plug

Tappo di scarico olio (magnetico)  
Oil drain plug (magnetic)



L'orientamento della foratura della flangia di fissaggio è come illustrato nelle schede dei dati dimensionali dei riduttori.

The mounting flange orientation is shown in each planetary gears technical sheets.



I codici in parentesi sono ad uso esclusivo dell' ufficio tecnico CHIARAVALLI.  
Codes in brackets are for CHIARAVALLI technical department use only.



## POSIZIONI DI MONTAGGIO

## MOUNTING POSITIONS

CMS CMC				
	B51 (A)	B55 (B)	B53 (C)	B54 (D)
CPS CPC				
	B51 (A)	B55 (B)	B53 (C)	B54 (D)
CF				
	B51 (A)	B55 (B)	B53 (C)	B54 (D)
CFS				
	B51 (A)	B55 (B)	B53 (C)	B54 (D)
CCPC				
	B56 (A)	B60 (B)	B58 (C)	B62 (D)
	B57 (E)	B61 (F)	B59 (G)	B63 (H)



I codici in parentesi sono ad uso esclusivo dell' ufficio tecnico CHIARAVALLI.  
Codes in brackets are for CHIARAVALLI technical department use only.



## POSIZIONI DI MONTAGGIO

## MOUNTING POSITIONS

CMS CMC				
	V15 (E)	V16 (F)	V17 (G)	V18 (H)
CPS CPC				
	V15 (E)	V16 (F)	V17 (G)	V18 (H)
CF				
	V15 (E)	V16 (F)	V17 (G)	V18 (H)
CFS				
	V15 (E)	V16 (F)	V17 (G)	V18 (H)
CCPC				
	V53 (I)	V52 (J)	V54 (K)	V55 (L)
	V49 (M)	V48 (N)	V50 (O)	V51 (P)



I codici in parentesi sono ad uso esclusivo dell' ufficio tecnico CHIARAVALLI.  
Codes in brackets are for CHIARAVALLI technical department use only.



## POSIZIONI DI MONTAGGIO

## MOUNTING POSITIONS

CMS CMC				
	V35 (I)	V36 (J)	V37 (K)	V38 (L)
CPS CPC				
	V35 (I)	V36 (J)	V37 (K)	V38 (L)
CF				
	V35 (I)	V36 (J)	V37 (K)	V38 (L)
CFS				
	V35 (I)	V36 (J)	V37 (K)	V38 (L)
CCPC				
	V42 (Q)	V40 (R)	V41 (S)	V43 (T)
	V46 (U)	V44 (V)	V45 (W)	V47 (X)



I codici in parentesi sono ad uso esclusivo dell' ufficio tecnico CHIARAVALLI.  
Codes in brackets are for CHIARAVALLI technical department use only.



## POSIZIONI DI MONTAGGIO

## MOUNTING POSITIONS

CMS  
CMC  
CPS  
CPC  
CF  
CFS

<b>C1 (01)</b>	<b>C2 (02)</b>	<b>C3 (03)</b>	<b>C4 (04)</b>
<b>C5 (05)</b>	<b>C6 (06)</b>	<b>C7 (07)</b>	<b>C8 (08)</b>
<b>C9 (01)</b>	<b>C10 (02)</b>	<b>C11 (03)</b>	<b>C12 (04)</b>
<b>C13 (05)</b>	<b>C14 (06)</b>	<b>C15 (07)</b>	<b>C16 (08)</b>
<b>C17 (09)</b>	<b>C18 (10)</b>	<b>C19 (11)</b>	<b>C20 (12)</b>
<b>C21 (13)</b>	<b>C22 (14)</b>	<b>C23 (15)</b>	<b>C24 (16)</b>

CCPC



I codici in parentesi sono ad uso esclusivo dell' ufficio tecnico CHIARAVALLI.  
Codes in brackets are for CHIARAVALLI technical department use only.



## POSIZIONI DI MONTAGGIO

## MOUNTING POSITIONS

CMS CMC					
	C25 (09)	C26 (10)	C27 (11)	C28 (12)	
	CPS CPC				
		C25 (09)	C26 (10)	C27 (11)	C28 (12)
CF					
		C25 (09)	C26 (10)	C27 (11)	C28 (12)
	CFS				
		C25 (09)	C26 (10)	C27 (11)	C28 (12)
CCPC					
		C41 (17)	C42 (18)	C43 (19)	C44 (20)
	C45 (21)	C46 (22)	C47 (23)	C48 (24)	



I codici in parentesi sono ad uso esclusivo dell' ufficio tecnico CHIARAVALLI.  
Codes in brackets are for CHIARAVALLI technical department use only.



## POSIZIONI DI MONTAGGIO

## MOUNTING POSITIONS

CMS CMC				
	C29 (13)	C30 (14)	C31 (15)	C32 (16)
CPS CPC				
	C29 (13)	C30 (14)	C31 (15)	C32 (16)
CF				
	C29 (13)	C30 (14)	C31 (15)	C32 (16)
CFS				
	C29 (13)	C30 (14)	C31 (15)	C32 (16)
CCPC				
	C49 (25)	C50 (26)	C51 (27)	C52 (28)
	C53 (29)	C54 (30)	C55 (31)	C56 (32)



I codici in parentesi sono ad uso esclusivo dell' ufficio tecnico CHIARAVALLI.  
Codes in brackets are for CHIARAVALLI technical department use only.





## POSIZIONI DI MONTAGGIO

## MOUNTING POSITIONS

CMS CMC					
	C33 (17)	C34 (18)	C35 (19)	C36 (20)	
	CPS CPC				
		C33 (17)	C34 (18)	C35 (19)	C36 (20)
CF					
		C33 (17)	C34 (18)	C35 (19)	C36 (20)
	CFS				
		C33 (17)	C34 (18)	C35 (19)	C36 (20)
CCPC					
		C57 (33)	C58 (34)	C59 (35)	C60 (36)
	C61 (37)	C62 (38)	C63 (39)	C64 (40)	



I codici in parentesi sono ad uso esclusivo dell' ufficio tecnico CHIARAVALLI.  
Codes in brackets are for CHIARAVALLI technical department use only.



## POSIZIONI DI MONTAGGIO

## MOUNTING POSITIONS

CMS  
CMC

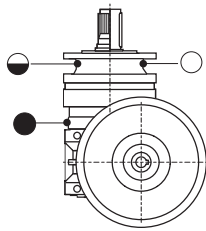

C37 (21)

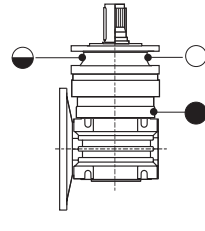

C38 (22)

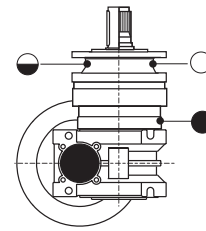

C39 (23)

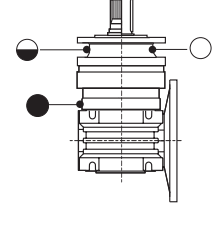

C40 (24)

CPS  
CPC

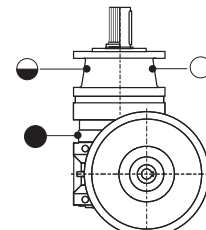

C37 (21)

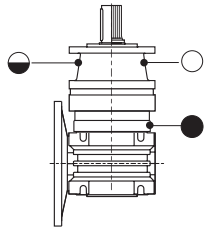

C38 (22)

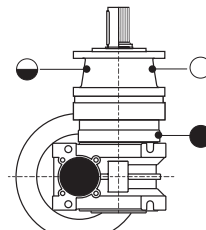

C39 (23)

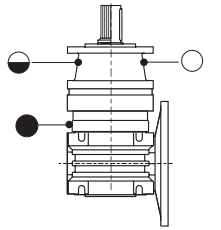

C40 (24)

CF

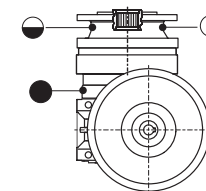

C37 (21)

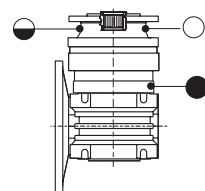

C38 (22)

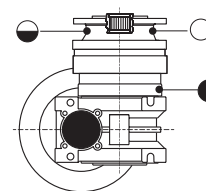

C39 (23)

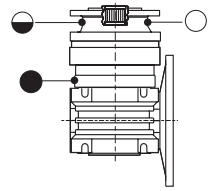

C40 (24)

CFS

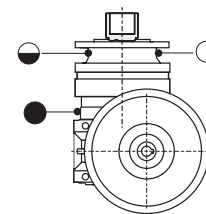

C37 (21)

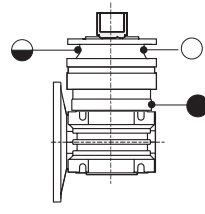

C38 (22)

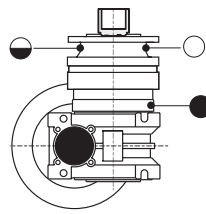

C39 (23)

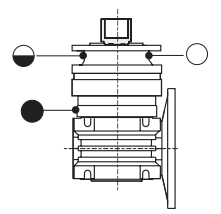

C40 (24)

CCPC

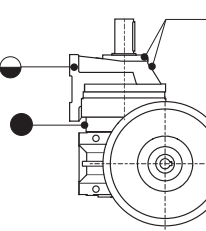

C65 (41)

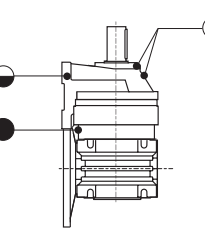

C66 (42)

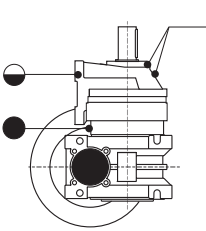

C67 (43)

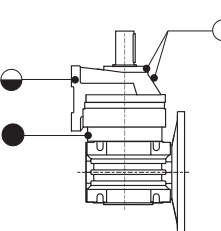

C68 (44)

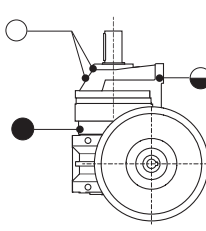

C69 (45)

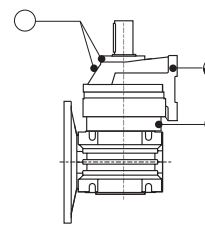

C70 (46)

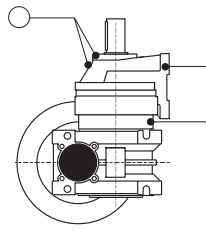

C71 (47)

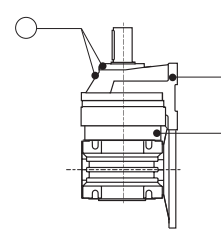



C72 (48)



I codici in parentesi sono ad uso esclusivo dell' ufficio tecnico CHIARAVALLI.  
Codes in brackets are for CHIARAVALLI technical department use only.

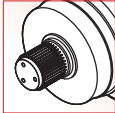
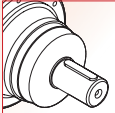
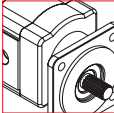
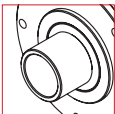
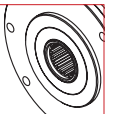
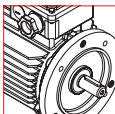
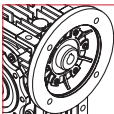

# CHPL/CHPLB 1000

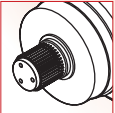
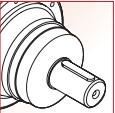
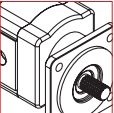
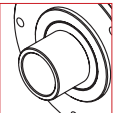
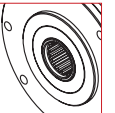
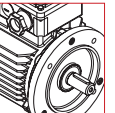
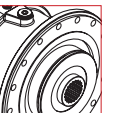

	<b>i</b>	<b>T<sub>2n</sub></b> (daNm)	<b>OUT</b>		<b>IN</b>	
<b>1001</b>	3.56 ÷ 8.67	33.3 ÷ 80.8	 Ø42	 40X36 DIN 5482	 Ø42	 Hydraulic Motor
<b>1002</b>	12.6 ÷ 58.5	51.3 ÷ 80.8	 Ø50	 40X36 DIN 5482	 Electric Motor	 Worm gearboxes
<b>1003</b>	54.2 ÷ 394.9	51.3 ÷ 80.8				
<b>1004</b>	337.4 ÷ 3422.2	51.3 ÷ 80.8			 Brake	

	<b>i</b>	<b>T<sub>2n</sub></b> (daNm)	<b>OUT</b>		<b>IN</b>	
<b>1002</b>	10.4 ÷ 19.8	51.3 ÷ 80.8	 Ø42	 40X36 DIN 5482	 Ø42	 Hydraulic Motor
<b>1003</b>	37.1 ÷ 171.6	51.3 ÷ 80.8	 Ø50	 40X36 DIN 5482	 Electric Motor	
<b>1004</b>	131.8 ÷ 1487.2	51.3 ÷ 80.8			 Brake	

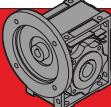

## DATI TECNICI

## TECHNICAL DATA



 <b>CHPL</b>	i	T <sub>2n</sub>	P <sub>1n</sub>	P <sub>t</sub>	IEC		 <b>CHM</b>	 <b>CM</b>
		(n <sub>1</sub> =1400 rpm)	(n <sub>1</sub> =1400 rpm)		(B5)			
		[daNm]	[kW]	[kW]				
<b>1001</b>	3.56	80.8	33.3	12	63 80 100 132	71 90 112 160	CHM 50 CHM 63 CHM 75	CM42
	4.29	80.8	27.6					
	5.6	58.0	15.2					
	6.75	51.3	11.1					
	8.67	33.3	5.6					
<b>1002</b>	12.6	80.8	9.4	8	63 80 100 132	71 90 112	CHM 50 CHM 63 CHM 75	CM42
	15.2	80.8	7.8					
	19.9	80.8	5.9					
	24	80.8	4.9					
	28.9	80.8	4.1					
	31.4	58.0	2.7					
	37.8	58.0	2.2					
	45.6	51.3	1.6					
	58.5	51.3	1.3					
<b>1003</b>	54.2	80.8	2.2	5	63 80 100 132	71 90 112	CHM 50 CHM 63 CHM 75	CM42
	65.3	80.8	1.8					
	70.8	80.8	1.7					
	78.7	80.8	1.5					
	85.3	80.8	1.4					
	102.9	80.8	1.2					
	111.5	80.8	1.1					
	134.4	80.8	0.88					
	162	80.8	0.73					
	172.6	80.8	0.69					
	208	80.8	0.57					
	211.7	58.0	0.40					
	255.2	58.0	0.33					
	271.8	58.0	0.31					
	307.5	51.3	0.24					
	327.6	58.0	0.26					
394.9	51.3	0.19						
<b>1004</b>	337.4	80.8	0.35	1.5	63 80	71 90	CHM 50 CHM 63 CHM 75	CM42
	365.7	80.8	0.32					
	396.4	80.8	0.30					
	440.8	80.8	0.27					
	477.9	80.8	0.25					
	531.3	80.8	0.22					
	576	80.8	0.21					
	624.4	80.8	0.19					
	694.3	80.8	0.17					
	752.6	80.8	0.16					
	836.9	80.8	0.14					
	907.2	80.8	0.13					
	966.3	80.8	0.12					
	1093.5	80.8	0.11					
	1144.5	80.8	0.10					
	1185.4	58.0	0.07					
	1318.1	80.8	0.09					
	1428.8	58.0	0.06					
1692.3	80.8	0.07						
3422.2	51.3	0.02						

n<sub>1max</sub> = 2800 rpm

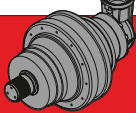

## DATI TECNICI

## TECHNICAL DATA

 CHPLB	i	T <sub>2n</sub> (n <sub>1</sub> =1400 rpm)	P <sub>1n</sub> (n <sub>1</sub> =1400 rpm)	P <sub>t</sub> [kW]	IEC		 CM
		[daNm]	[kW]		(B5)		
1002	10.4	80.8	11.4	8	63 80 100 132	71 90 112	CM42
	12.6	80.8	9.4				
	16.4	58.0	5.2				
	19.8	51.3	3.8				
1003	37.1	80.8	3.2	5	63 80 100 132	71 90 112	CM42
	44.7	80.8	2.6				
	53.9	80.8	2.2				
	58.4	80.8	2.0				
	70.4	80.8	1.7				
	84.9	80.8	1.4				
	92	58.0	0.9				
	110.9	58.0	0.8				
	133.6	51.3	0.6				
	171.6	51.3	0.4				
1004	131.8	80.8	0.9	1.5	63 80	71 90	CM42
	158.9	80.8	0.7				
	191.6	80.8	0.6				
	207.7	80.8	0.6				
	230.9	80.8	0.5				
	301.7	80.8	0.4				
	327.1	80.8	0.4				
	363.7	80.8	0.33				
	394.2	80.8	0.30				
	475.2	80.8	0.25				
	515.1	58.0	0.16				
	572.8	80.8	0.21				
	610.1	80.8	0.19				
	735.4	80.8	0.16				
	797.2	58.0	0.11				
	960.9	58.0	0.09				
	1158.3	51.3	0.06				
1233.8	58.0	0.07					
1487.2	51.3	0.05					

n<sub>1max</sub> = 2800 rpm



## DIMENSIONI CMS

## CMS DIMENSIONS

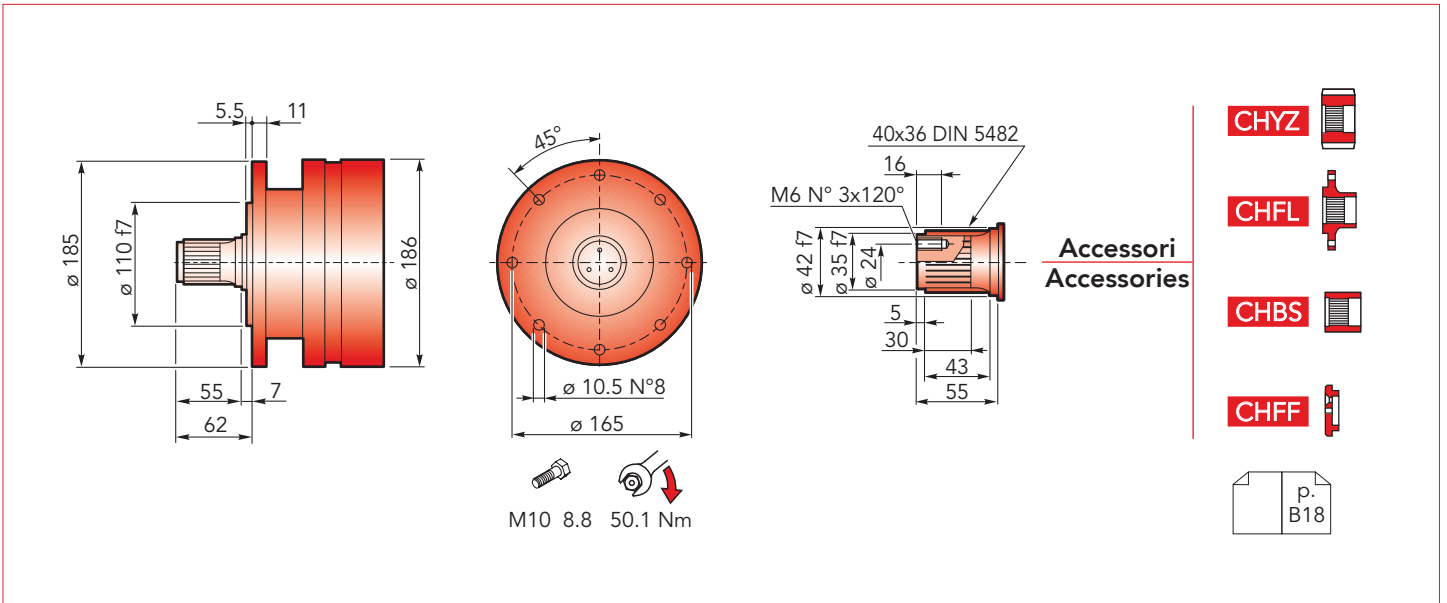

### CHPL 1000 CMS - Flange motori IEC

### CHPL 1000 CMS- IEC Motor flanges

CHPL	IEC 63			IEC 71			IEC 80			IEC 90			
	LP	P	ØD	LP	P	ØD	LP	P	ØD	LP	P	ØD	
1001	140			140			160			160			
1002	188	36	140	188	36	160	208	56	200	208	56	200	
1003	236			236						256			256
1004	284			284						304			304

CHPL	IEC 100			IEC 112			IEC 132			IEC 160		
	LP	P	ØD	LP	P	ØD	LP	P	ØD	LP	P	ØD
1001	170			170			204			243	139	350
1002	218	66	250	218	66	250	252	100	300	-		
1003	266			266			300			-		
1004	-			-			-			-		

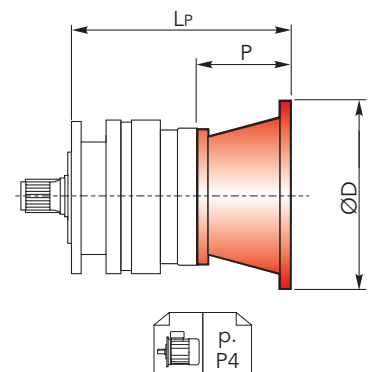

### CHPL 1000 CMS - Alberi maschi entrata

### CHPL 1000 CMS - Male input shafts

CHPL	CM42			
	LT	T	LE	ØE
1001	197			
1002	245	93	82	42 h6
1003	293			
1004	341			

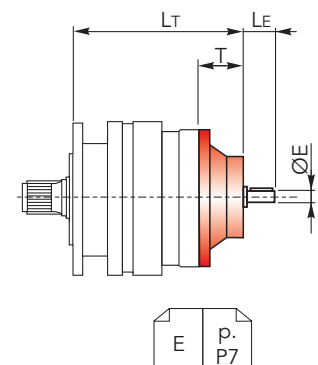



## DIMENSIONI CMS

## CMS DIMENSIONS

CHPL/CHPLB 1000

CHPL 1000 CMS - Riduttore a vite senza fine CHM in entrata CHPL 1000 CMS - CHM input worm gearboxes

CHPL	CHM 50					CHM 63				
	Lv	I	H	M	N	Lv	I	H	M	N
1001	229.5	50	110	60	80	239	63	135	72	95
1002	277.5					287				
1003	325.5					335				
1004	373.5					383				

CHPL	CHM 75				
	Lv	I	H	M	N
1001	218	75	161	86	112.5
1002	266				
1004	314				
1004	362				

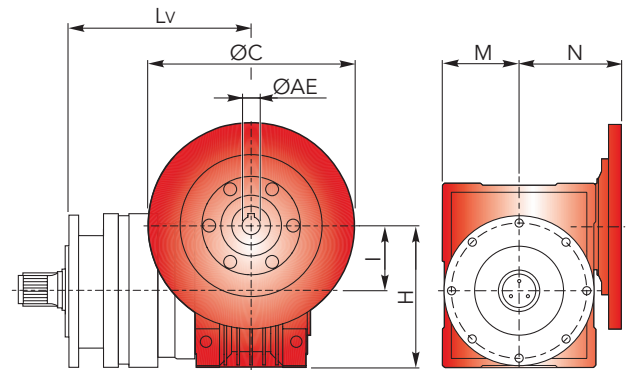

CHPLB 1000 CMS - Flange motori IEC

CHPLB 1000 CMS - IEC Motor flanges

CHPLB	IEC 63				IEC 71				IEC 80				IEC 90			
	L	LP	P	ØD	L	LP	P	ØD	L	LP	P	ØD	L	LP	P	ØD
1002	179	196	36	140	179	196	36	160	179	216	56	200	179	216	56	200
1003	227				227				227				227			
1004	275				275				275				275			

CHPLB	IEC 100				IEC 112				IEC 132				
	L	LP	P	ØD	L	LP	P	ØD	L	LP	P	ØD	
1002	179	226	66	250	179	226	66	250	179	260	100	300	
1003	227				227				227				227
1004	-				-				-				-

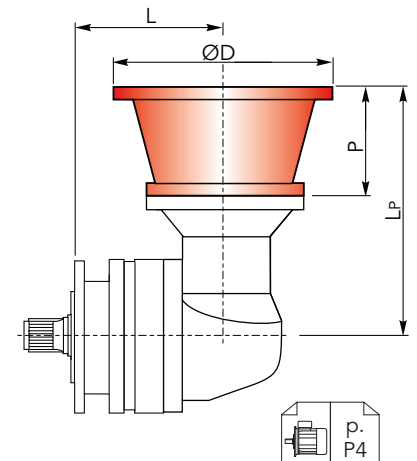

CHPLB 1000 CMS - Alberi maschi entrata

CHPL 1000 CMS - Male input shafts

CHPLB	CM42				
	L	L <sub>T</sub>	T	L <sub>E</sub>	ØE
1002	179	253	93	82	42 h6
1003	227				
1004	275				

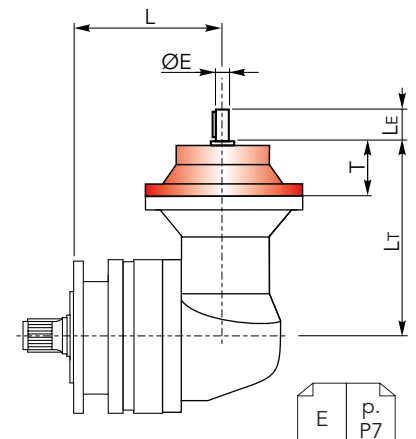



## DIMENSIONI CMC

## CMC DIMENSIONS

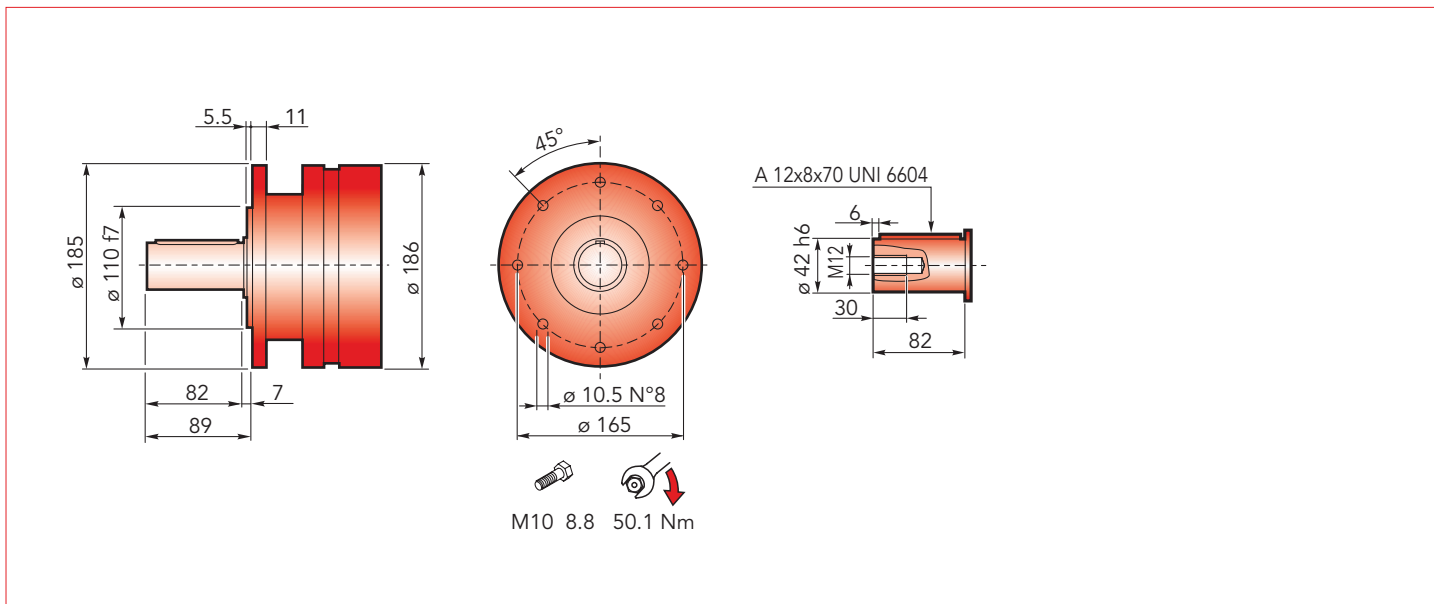

### CHPL 1000 CMC - Flange motori IEC

### CHPL 1000 CMC- IEC Motor flanges

CHPL	IEC 63			IEC 71			IEC 80			IEC 90		
	Lp	P	ØD	Lp	P	ØD	Lp	P	ØD	Lp	P	ØD
1001	140	36	140	140	36	160	160	56	200	160	56	200
1002	188			188			208					
1003	236			236			256					
1004	284			284			304					

CHPL	IEC 100			IEC 112			IEC 132			IEC 160		
	Lp	P	ØD	Lp	P	ØD	Lp	P	ØD	Lp	P	ØD
1001	170	66	250	170	66	250	204	100	300	243	139	350
1002	218			218			252			-		
1003	266			266			300			-		
1004	-			-			-			-		

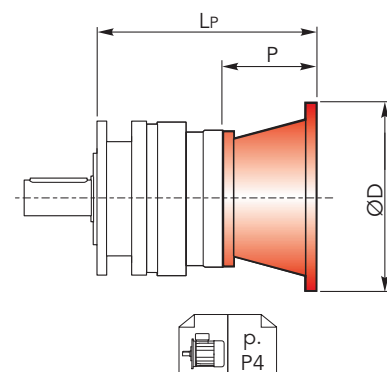

### CHPL 1000 CMC - Alberi maschi entrata

### CHPL 1000 CMC - Male input shafts

CHPL	CM42			
	Lt	T	Le	ØE
1001	197	93	82	42 h6
1002	245			
1003	293			
1004	341			

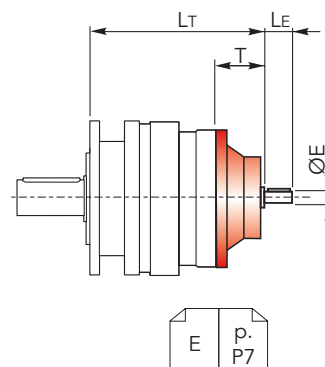





## DIMENSIONI CMC

## CMC DIMENSIONS

CHPL/CHPLB 1000

CHPL 1000 CMC - Riduttore a vite senza fine CHM in entrata CHPL 1000 CMC - CHM input worm gearboxes

CHPL	CHM 50					CHM 63				
	Lv	I	H	M	N	Lv	I	H	M	N
1001	229.5	50	110	60	80	239	63	135	72	95
1002	277.5					287				
1003	325.5					335				
1004	373.5					383				

CHPL	CHM 75				
	Lv	I	H	M	N
1001	218	75	161	86	112.5
1002	266				
1004	314				
1004	362				

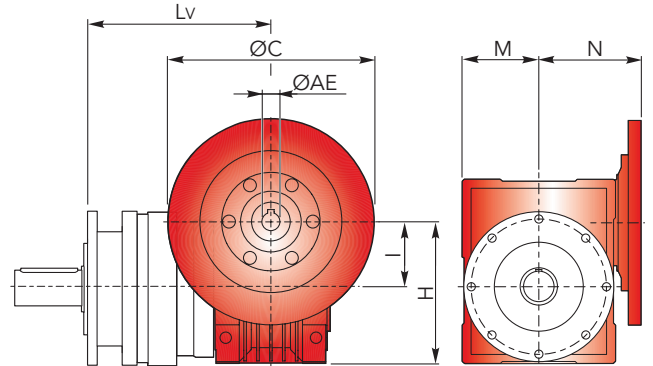

CHPLB 1000 CMC - Flange motori IEC

CHPLB 1000 CMC - IEC Motor flanges

CHPLB	IEC 63				IEC 71				IEC 80				IEC 90			
	L	LP	P	ØD	L	LP	P	ØD	L	LP	P	ØD	L	LP	P	ØD
1002	179	196	36	140	179	196	36	160	179	216	56	200	179	216	56	200
1003	227				227				227							
1004	275				275				275							

CHPLB	IEC 100				IEC 112				IEC 132			
	L	LP	P	ØD	L	LP	P	ØD	L	LP	P	ØD
1002	179	226	66	250	179	226	66	250	179	260	100	300
1003	227				227				227			
1004	-				-				-			

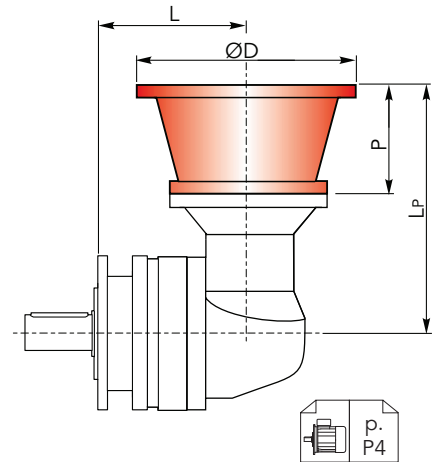

CHPLB 1000 CMC - Alberi maschi entrata

CHPL 1000 CMC - Male input shafts

CHPLB	CM42				
	L	LT	T	LE	ØE
1002	179	253	93	82	42 h6
1003	227				
1004	275				

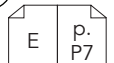
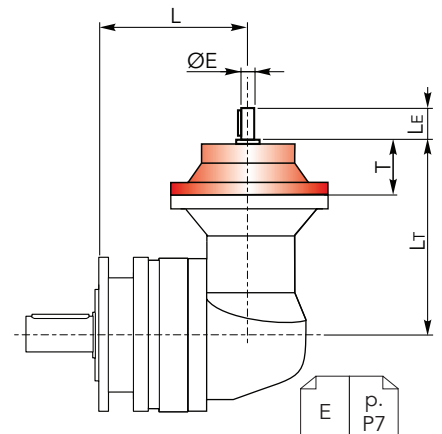



## DIMENSIONI CPS

## CPS DIMENSIONS

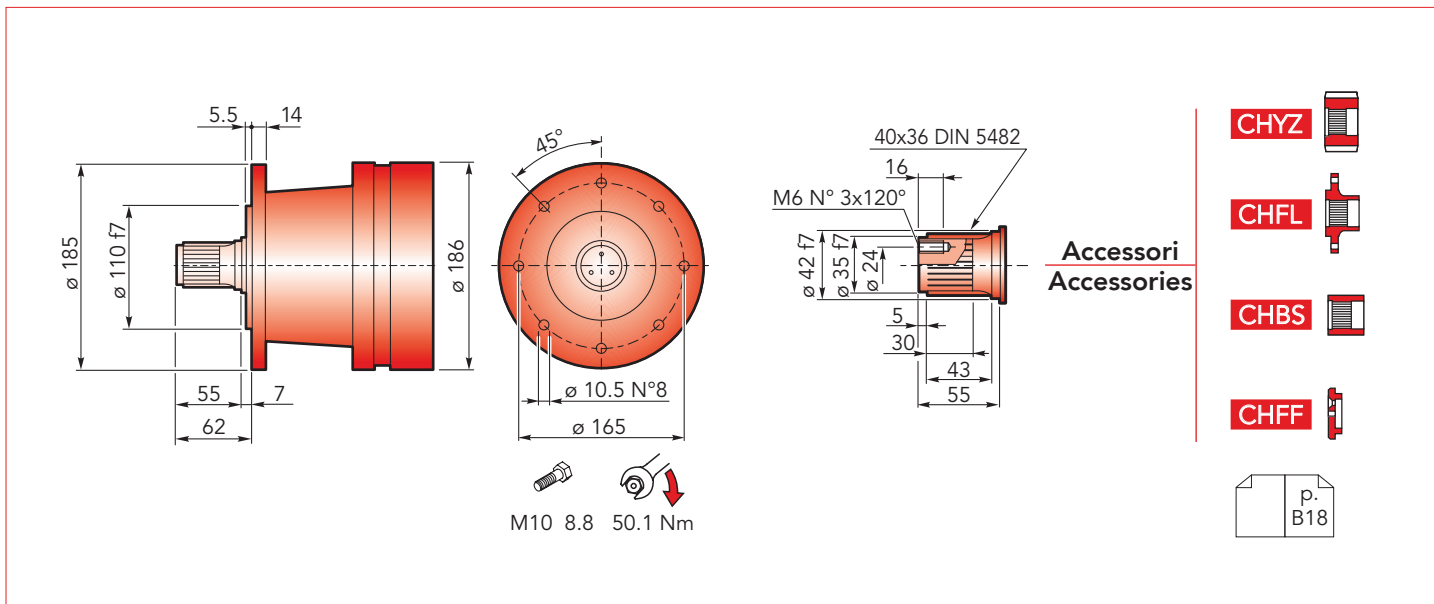

### CHPL 1000 CPS - Flange motori IEC

### CHPL 1000 CPS- IEC Motor flanges

CHPL	IEC 63			IEC 71			IEC 80			IEC 90		
	LP	P	ØD	LP	P	ØD	LP	P	ØD	LP	P	ØD
1001	170	36	140	170	36	160	190	56	200	190	56	200
1002	218			218			238					
1003	266			266			286					
1004	314			314			334					

CHPL	IEC 100			IEC 112			IEC 132			IEC 160		
	LP	P	ØD	LP	P	ØD	LP	P	ØD	LP	P	ØD
1001	200	66	250	200	66	250	234	100	300	273	139	350
1002	248			248			-					
1003	296			296			-					
1004	-			-			-					

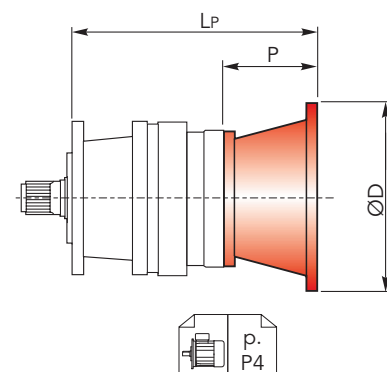

### CHPL 1000 CPS - Alberi maschi entrata

### CHPL 1000 CPS - Male input shafts

CHPL	CM42			
	LT	T	LE	ØE
1001	227	93	82	42 h6
1002	275			
1003	323			
1004	371			

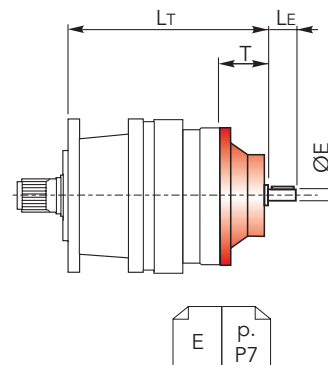



## DIMENSIONI CPS

## CPS DIMENSIONS

CHPL/CHPLB 1000

CHPL 1000 CPS - Riduttore a vite senza fine CHM in entrata

CHPL 1000 CPS - CHM input worm gearboxes

CHPL	CHM 50					CHM 63				
	Lv	I	H	M	N	Lv	I	H	M	N
1001	259.5	50	110	60	80	269	63	135	72	95
1002	307.5					317				
1003	355.5					365				
1004	403.5					413				

CHPL	CHM 75				
	Lv	I	H	M	N
1001	248	75	161	86	112.5
1002	296				
1003	344				
1004	392				

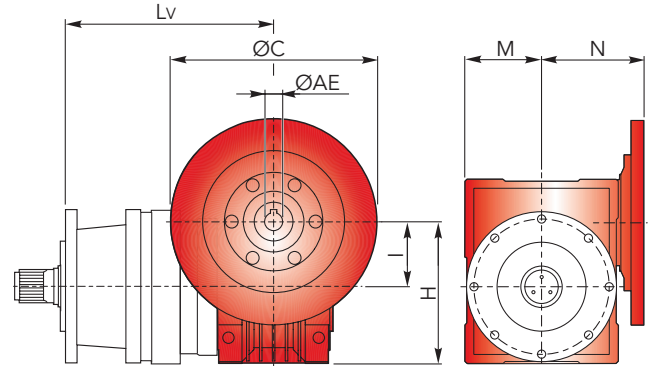

CHPLB 1000 CPS - Flange motori IEC

CHPLB 1000 CPS - IEC Motor flanges

CHPLB	IEC 63				IEC 71				IEC 80				IEC 90			
	L	LP	P	ØD	L	LP	P	ØD	L	LP	P	ØD	L	LP	P	ØD
1002	209	196	36	140	209	196	36	160	209	216	56	200	209	216	56	200
1003	257				257				257				257			
1004	305				305				305				305			

CHPLB	IEC 100				IEC 112				IEC 132				
	L	LP	P	ØD	L	LP	P	ØD	L	LP	P	ØD	
1002	209	226	66	250	209	226	66	250	209	260	100	300	
1003	257				257				257				257
1004	-				-				-				-

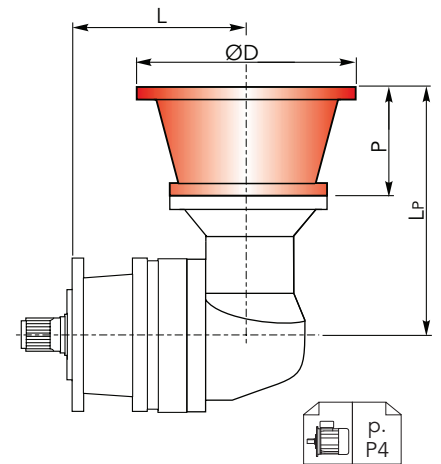

CHPLB 1000 CPS - Alberi maschi entrata

CHPL 1000 CPS - Male input shafts

CHPLB	CM42				
	L	L <sub>T</sub>	T	L <sub>E</sub>	ØE
1002	209	253	93	82	42 h6
1003	257				
1004	305				

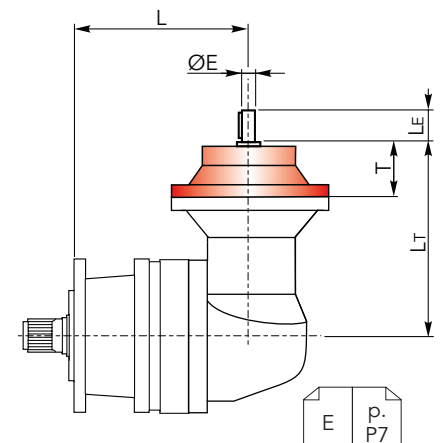



## DIMENSIONI CPC

## CPC DIMENSIONS

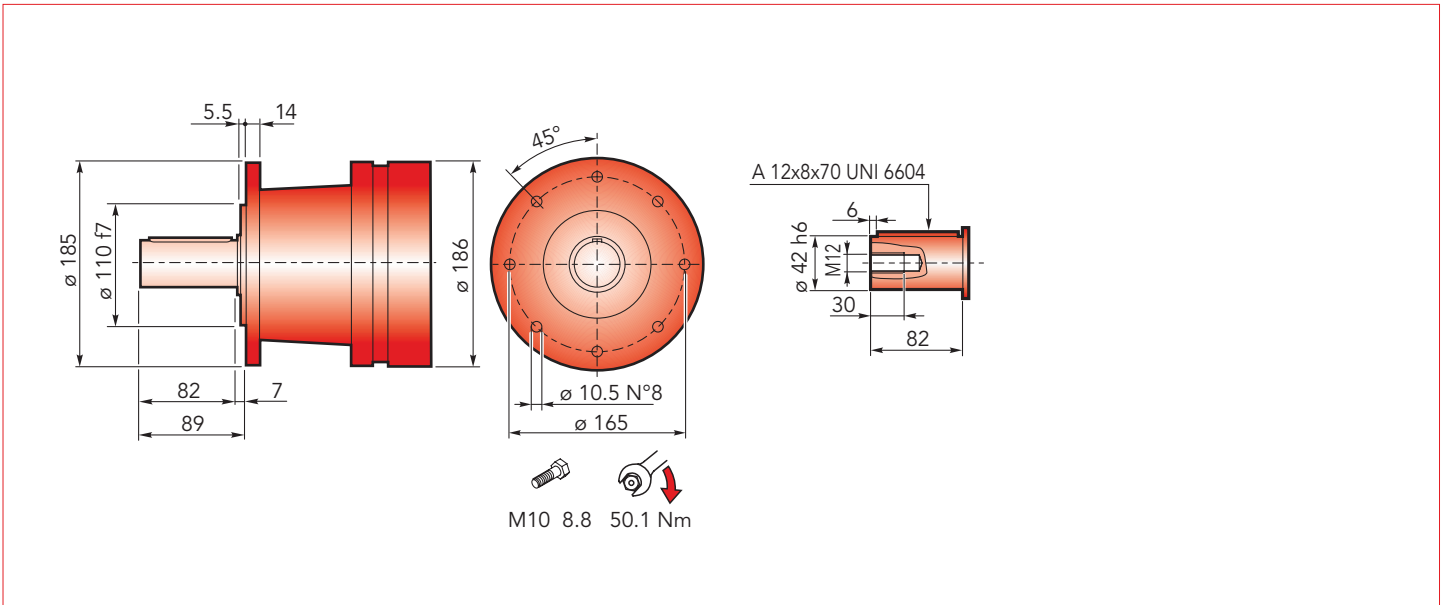

### CHPL 1000 CPC - Flange motori IEC

### CHPL 1000 CPC- IEC Motor flanges

CHPL	IEC 63			IEC 71			IEC 80			IEC 90		
	LP	P	ØD	LP	P	ØD	LP	P	ØD	LP	P	ØD
1001	170			170			190			190		
1002	218	36	140	218	36	160	238	56	200	238	56	200
1003	266			266			286			286		
1004	314			314			334			334		

CHPL	IEC 100			IEC 112			IEC 132			IEC 160		
	LP	P	ØD	LP	P	ØD	LP	P	ØD	LP	P	ØD
1001	200			200			234			273	139	350
1002	248	66	250	248	66	250	282	100	300	-		
1003	296			296			330			-		
1004	-			-			-					

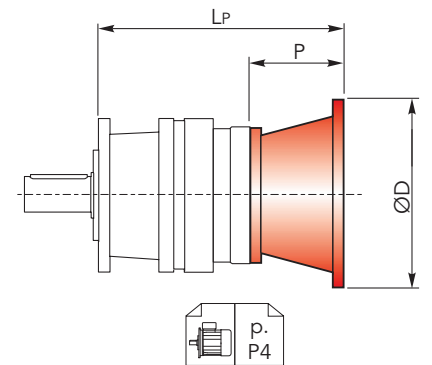

### CHPL 1000 CPC - Alberi maschi entrata

### CHPL 1000 CPC - Male input shafts

CHPL	CM42			
	LT	T	LE	ØE
1001	227			
1002	275	93	82	42 h6
1003	323			
1004	371			

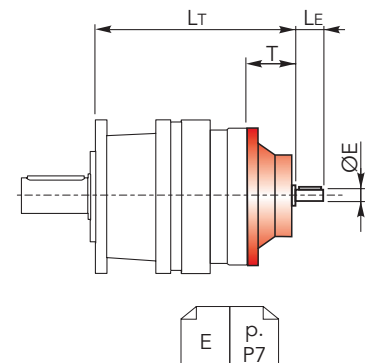



## DIMENSIONI CPC

## CPC DIMENSIONS

CHPL/CHPLB 1000

CHPL 1000 CPC - Riduttore a vite senza fine CHM in entrata

CHPL 1000 CPC - CHM input worm gearboxes

CHPL	CHM 50					CHM 63				
	Lv	I	H	M	N	Lv	I	H	M	N
1001	259.5	50	110	60	80	269	63	135	72	95
1002	307.5					317				
1003	355.5					365				
1004	403.5					413				

CHPL	CHM 75				
	Lv	I	H	M	N
1001	248	75	161	86	112.5
1002	296				
1003	344				
1004	392				

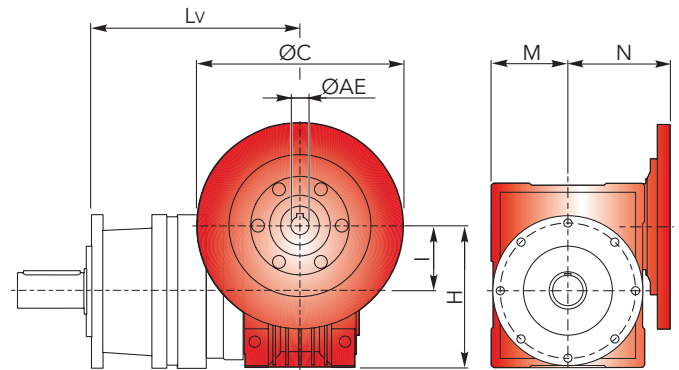

CHPLB 1000 CPC - Flange motori IEC

CHPLB 1000 CPC - IEC Motor flanges

CHPLB	IEC 63				IEC 71				IEC 80				IEC 90			
	L	LP	P	ØD	L	LP	P	ØD	L	LP	P	ØD	L	LP	P	ØD
1002	209	196	36	140	209	196	36	160	209	216	56	200	209	216	56	200
1003	257				257				257				257			
1004	305				305				305				305			

CHPLB	IEC 100				IEC 112				IEC 132				
	L	LP	P	ØD	L	LP	P	ØD	L	LP	P	ØD	
1002	209	226	66	250	209	226	66	250	209	260	100	300	
1003	257				257				257				257
1004	-				-				-				-

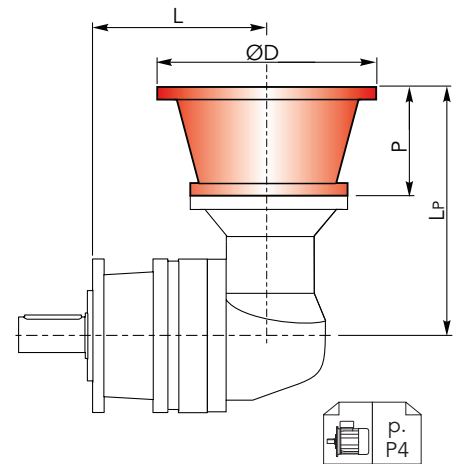

CHPLB 1000 CPC - Alberi maschi entrata

CHPL 1000 CPC - Male input shafts

CHPLB	CM42				
	L	L <sub>T</sub>	T	L <sub>E</sub>	ØE
1002	209	253	93	82	42 h6
1003	257				
1004	305				

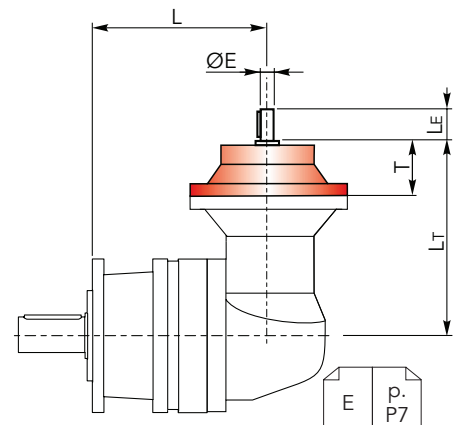



## DIMENSIONI CF

## CF DIMENSIONS

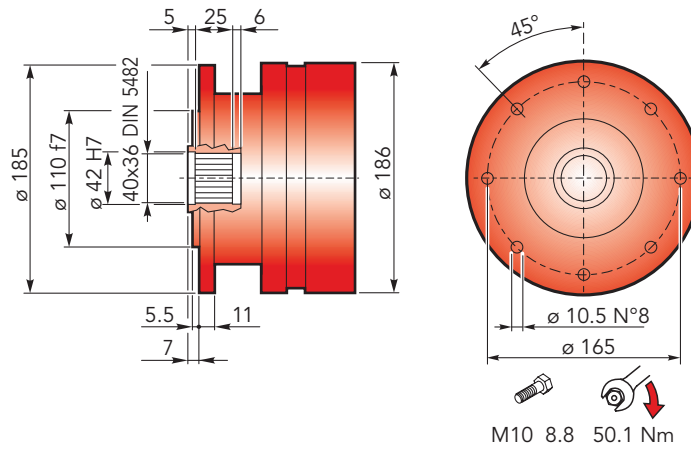

Accessori  
Accessories

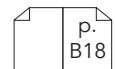

### CHPL 1000 CF - Flange motori IEC

### CHPL 1000 CF- IEC Motor flanges

CHPL	IEC 63			IEC 71			IEC 80			IEC 90		
	L <sub>P</sub>	P	ØD	L <sub>P</sub>	P	ØD	L <sub>P</sub>	P	ØD	L <sub>P</sub>	P	ØD
1001	140	36	140	140	36	160	56	200	160	56	200	
1002	188			188					208			208
1003	236			236					256			256
1004	284			284					304			304

CHPL	IEC 100			IEC 112			IEC 132			IEC 160		
	L <sub>P</sub>	P	ØD	L <sub>P</sub>	P	ØD	L <sub>P</sub>	P	ØD	L <sub>P</sub>	P	ØD
1001	170	66	250	170	66	250	100	300	204	243	139	350
1002	218			218					252	-		
1003	266			266					300	-		
1004	-			-					-	-		

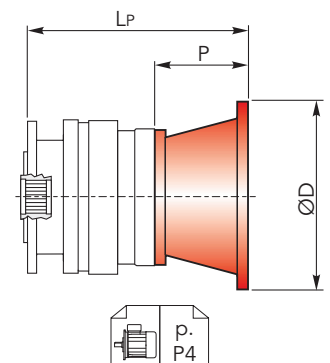

### CHPL 1000 CF - Alberi maschi entrata

### CHPL 1000 CF - Male input shafts

CHPL	CM42			
	L <sub>T</sub>	T	L <sub>E</sub>	ØE
1001	197	93	82	42 h6
1002	245			
1003	293			
1004	341			

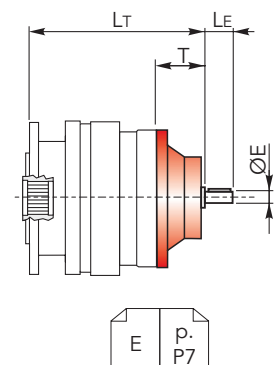



## DIMENSIONI CF

## CF DIMENSIONS

CHPL/CHPLB 1000

CHPL 1000 CF - Riduttore a vite senza fine CHM in entrata

CHPL 1000 CF - CHM input worm gearboxes

CHPL	CHM 50					CHM 63				
	Lv	I	H	M	N	Lv	I	H	M	N
1001	229.5	50	110	60	80	239	63	135	72	95
1002	277.5					287				
1003	325.5					335				
1004	373.5					383				

CHPL	CHM 75				
	Lv	I	H	M	N
1001	218	75	161	86	112.5
1002	266				
1003	314				
1004	362				

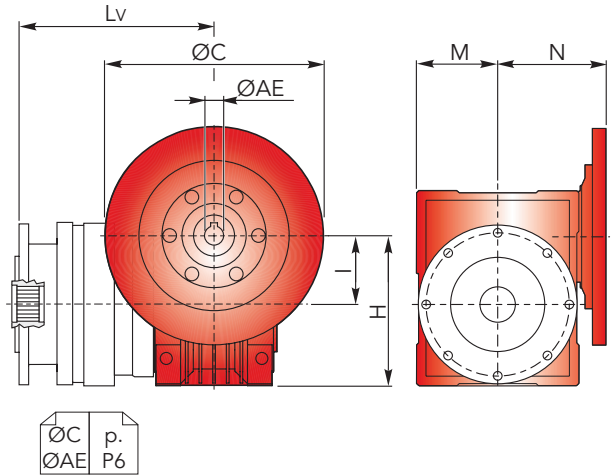

CHPLB 1000 CF - Flange motori IEC

CHPLB 1000 CF - IEC Motor flanges

CHPLB	IEC 63				IEC 71				IEC 80				IEC 90			
	L	LP	P	ØD	L	LP	P	ØD	L	LP	P	ØD	L	LP	P	ØD
1002	179	196	36	140	179	196	36	160	179	216	56	200	179	216	56	200
1003	227				227				227							
1004	275				275				275							

CHPLB	IEC 100				IEC 112				IEC 132			
	L	LP	P	ØD	L	LP	P	ØD	L	LP	P	ØD
1002	179	226	66	250	179	226	66	250	179	260	100	300
1003	227				227				227			
1004	-				-				-			

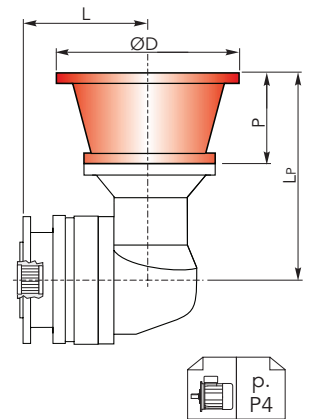

CHPLB 1000 CF - Alberi maschi entrata

CHPL 1000 CF - Male input shafts

CHPLB	CM42				
	L	LT	T	LE	ØE
1002	179	253	93	82	42 h6
1003	227				
1004	275				

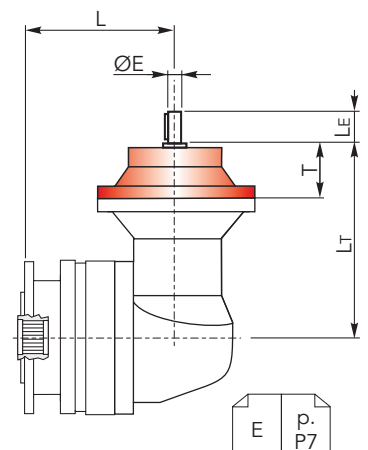



## DIMENSIONI CFS

## CFS DIMENSIONS

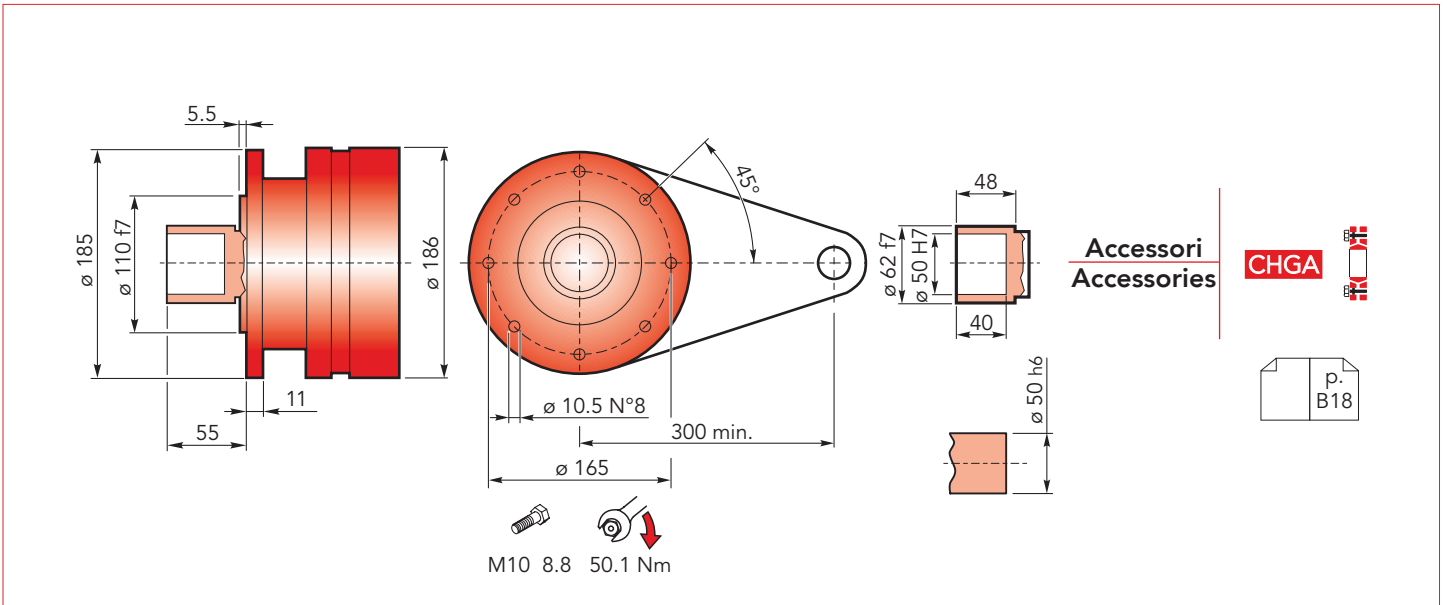

Accessori  
Accessories

**CHGA**

p. B18

### CHPL 1000 CFS - Flange motori IEC

### CHPL 1000 CFS- IEC Motor flanges

CHPL	IEC 63			IEC 71			IEC 80			IEC 90		
	Lp	P	ØD	Lp	P	ØD	Lp	P	ØD	Lp	P	ØD
1001	140	36	140	140	36	160	160	56	200	160	56	200
1002	188			188			208					
1003	236			236			256					
1004	284			284			304					

CHPL	IEC 100			IEC 112			IEC 132			IEC 160		
	Lp	P	ØD	Lp	P	ØD	Lp	P	ØD	Lp	P	ØD
1001	170	66	250	170	66	250	204	100	300	243	139	350
1002	218			218			252			-		
1003	266			266			300			-		
1004	-			-			-			-		

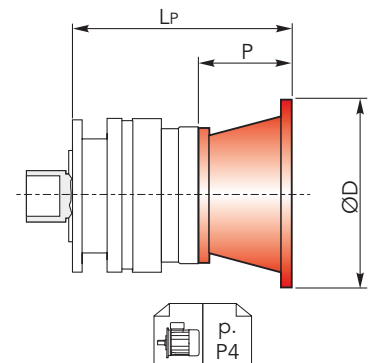

### CHPL 1000 CFS - Alberi maschi entrata

### CHPL 1000 CFS - Male input shafts

CHPL	CM42			
	Lt	T	Le	ØE
1001	197	93	82	42 h6
1002	245			
1003	293			
1004	341			

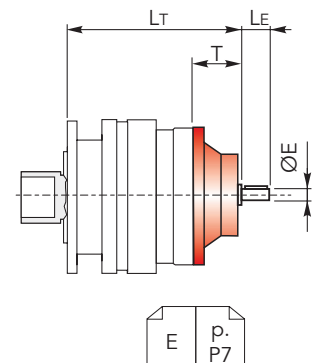





## DIMENSIONI CFS

## CFS DIMENSIONS

CHPL/CHPLB 1000

CHPL 1000 CFS - Riduttore a vite senza fine CHM in entrata

CHPL 1000 CFS - CHM input worm gearboxes

CHPL	CHM 50					CHM 63				
	Lv	I	H	M	N	Lv	I	H	M	N
1001	229.5	50	110	60	80	239	63	135	72	95
1002	277.5					287				
1003	325.5					335				
1003	373.5					383				

CHPL	CHM 75				
	Lv	I	H	M	N
1001	218	75	161	86	112.5
1002	266				
1003	314				
1004	362				

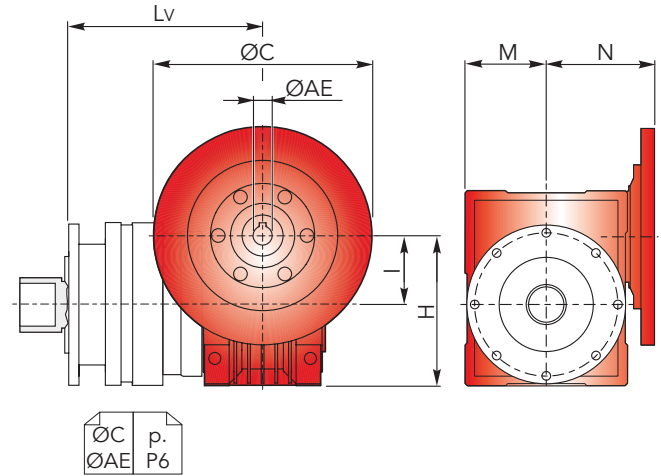

CHPLB 1000 CFS - Flange motori IEC

CHPLB 1000 CFS - IEC Motor flanges

CHPLB	IEC 63				IEC 71				IEC 80				IEC 90			
	L	LP	P	ØD	L	LP	P	ØD	L	LP	P	ØD	L	LP	P	ØD
1002	179	196	36	140	179	196	36	160	179	216	56	200	179	216	56	200
1003	227				227				227							
1004	275				275				275							

CHPLB	IEC 100				IEC 112				IEC 132			
	L	LP	P	ØD	L	LP	P	ØD	L	LP	P	ØD
1002	179	226	66	250	179	226	66	250	179	260	100	300
1003	227				227				227			
1004	-				-				-			

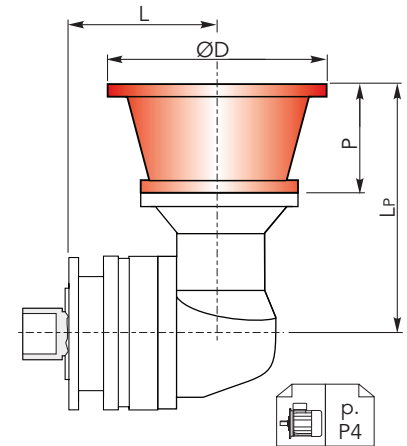

CHPLB 1000 CFS - Alberi maschi entrata

CHPL 1000 CFS - Male input shafts

CHPLB	CM42				
	L	L <sub>T</sub>	T	L <sub>E</sub>	ØE
102	179	253	93	82	42 h6
103	227				
104	275				

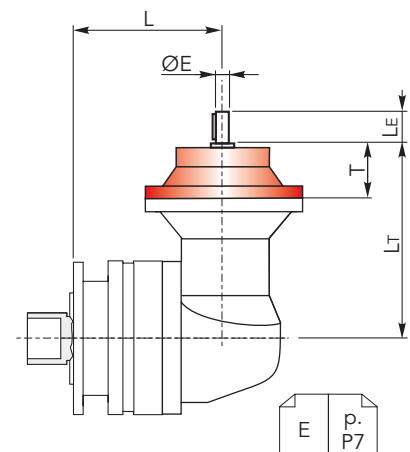



## DIMENSIONI CCPC

## CCPC DIMENSIONS

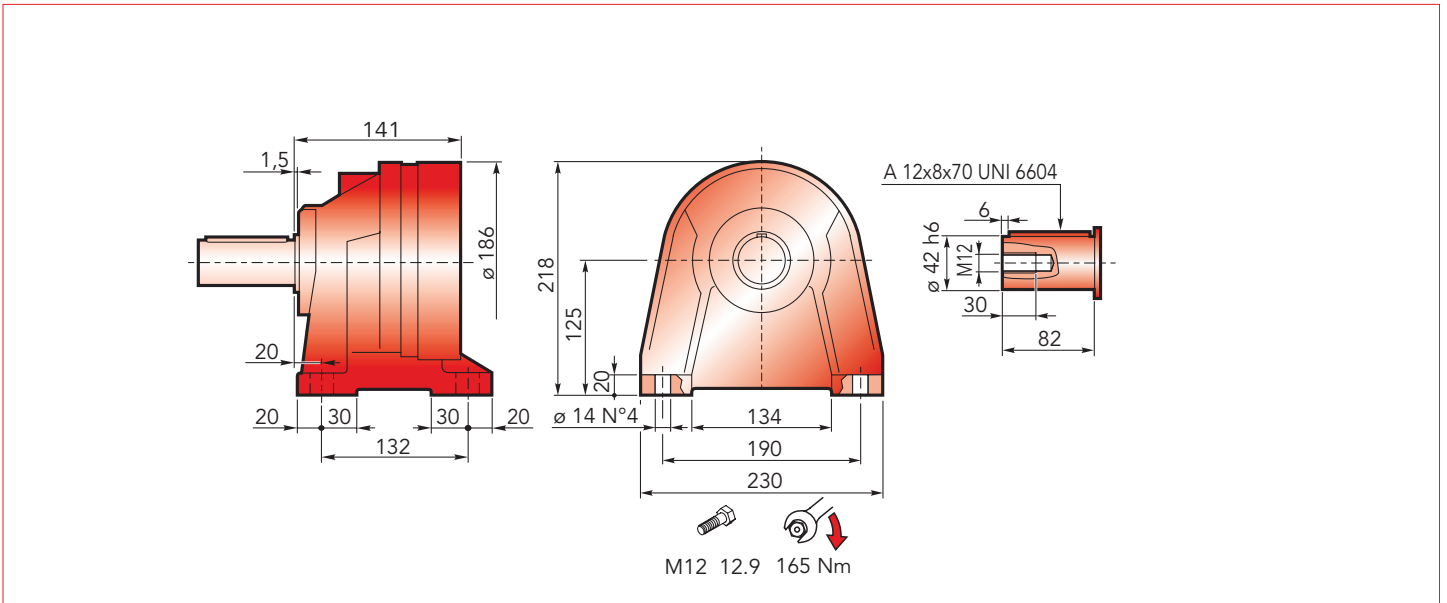

### CHPL 1000 CCPC - Flange motori IEC

### CHPL 1000 CCPC- IEC Motor flanges

CHPL	IEC 63			IEC 71			IEC 80			IEC 90		
	LP	P	ØD	LP	P	ØD	LP	P	ØD	LP	P	ØD
1001	177	36	140	177	36	160	197	56	200	197	56	200
1002	225			225			245			245		
1003	273			273			293			293		
1004	321			321			341			341		

CHPL	IEC 100			IEC 112			IEC 132			IEC 160		
	LP	P	ØD	LP	P	ØD	LP	P	ØD	LP	P	ØD
1001	207	66	250	207	66	250	241	100	300	280	139	350
1002	255			255			289			-		
1003	303			303			337			-		
1004	-			-			-			-		

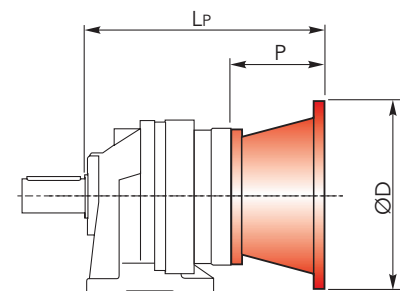

### CHPL 1000 CCPC - Alberi maschi entrata

### CHPL 1000 CCPC - Male input shafts

CHPL	CM42			
	LT	T	LE	ØE
1001	234	93	82	42 h6
1002	282			
1003	330			
1004	379			

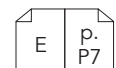
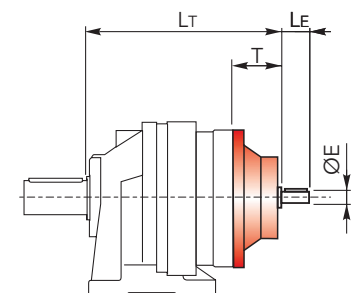



## DIMENSIONI CCPC

## CCPC DIMENSIONS

CHPL/CHPLB 1000

CHPL 1000 CCPC - Riduttore a vite senza fine CHM in entrata CHPL 1000 CCPC - CHM input worm gearboxes

CHPL	CHM 50					CHM 63				
	Lv	I	H	M	N	Lv	I	H	M	N
1001	266.5	50	110	60	80	276	63	135	72	95
1002	314.5					324				
1003	362.5					372				
1004	410.5					420				

CHPL	CHM 75				
	Lv	I	H	M	N
1001	255	75	161	86	112.5
1002	303				
1003	351				
1004	399				

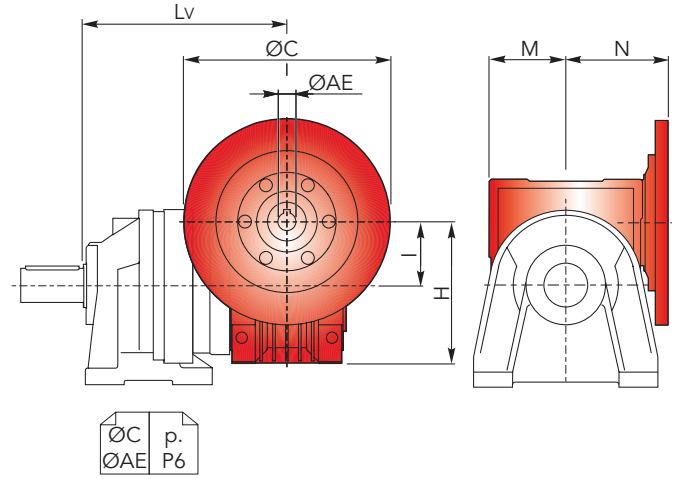

CHPLB 1000 CCPC - Flange motori IEC

CHPLB 1000 CCPC - IEC Motor flanges

CHPLB	IEC 71				IEC 71				IEC 80				IEC 90			
	L	LP	P	ØD	L	LP	P	ØD	L	LP	P	ØD	L	LP	P	ØD
1002	216	196	36	140	216	196	36	160	216	216	56	200	216	216	56	200
1003	264				264				264							
1004	312				312				312							

CHPLB	IEC 100				IEC 112				IEC 132			
	L	LP	P	ØD	L	LP	P	ØD	L	LP	P	ØD
1002	216	226	66	250	216	226	66	250	216	260	100	300
1003	264				264				264			
1004	-				-				-			

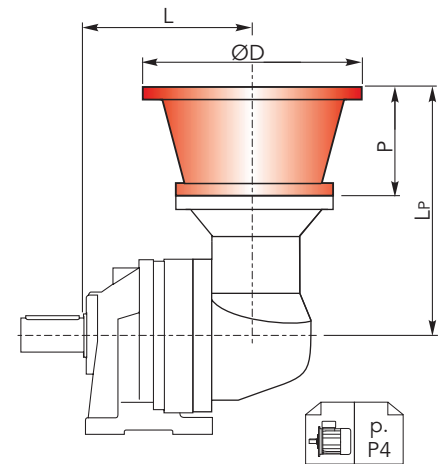

CHPLB 1000 CCPC - Alberi maschi entrata

CHPL 1000 CCPC - Male input shafts

CHPLB	CM42				
	L	LT	T	LE	ØE
1002	216	253	93	82	42 h6
1003	264				
1004	312				

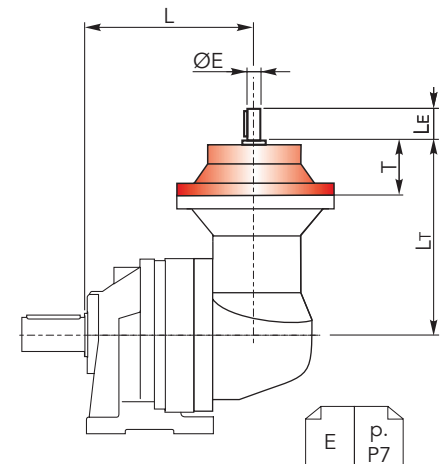



## ACCESSORI

## ACCESSORIES

## CHYZ Pignoni / Pinions

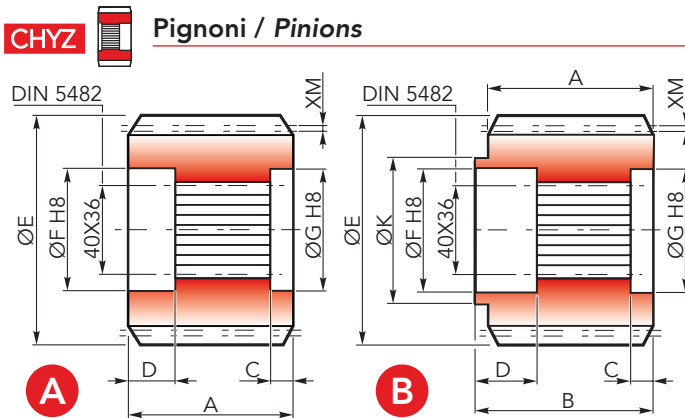

	Uscita / Output	M	Z	XM	A	B	C	D	E	F	G	K	Codice / Code
A	CMS	1.9	20	0.05	65	-	6	20.5	84.5	42	42	-	1071.200.042
	CPS	5	16	2.5	55	-	6	20.5	95	42	42	-	1071.259.042
B	CMS	3.5	23	0	40	60.5	6	20.5	87.5	42	42	60	1071.291.042

## CHFF Fondello di arresto / Stop bottom plate

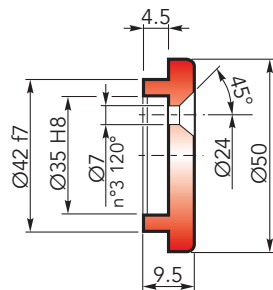

Codice / Code:  
1075.034.000

## CHBS Boccola scanalata / Splined bushing

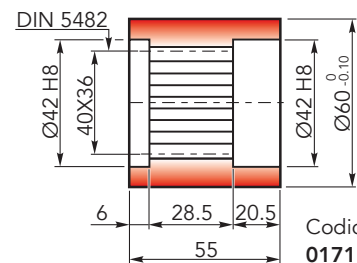

Codice / Code:  
0171.100.076

## CHKB Barra scanalata / Splined rod

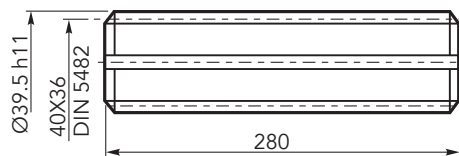

Codice / Code:  
3071.179.042

## CHFL Flangia / Flange

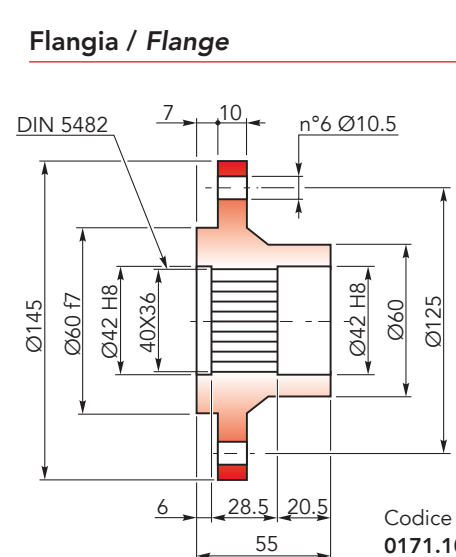

Codice / Code:  
0171.102.025

## CHGA Giunto di attrito / Shrink disc

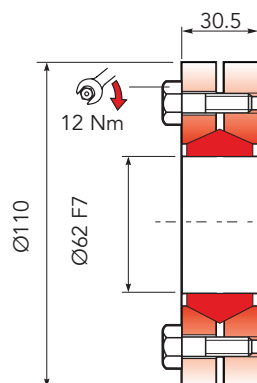

Coppia max: 2200 Nm (1)  
Max Torque: 2200 Nm (1)

Codice / Code:  
5109.062.000

(1): Coppia max indicata è valida solo con calettatori forniti da Chiaravalli S.p.A.  
(1): The maximum torque indicated is valid only with shrink discs supplied by Chiaravalli S.p.A.



## CARICHI RADIALI ( $F_r$ )

Nel diagramma seguente, sono indicati i carichi radiali  $F_r$  (N) applicabili sull'albero uscita in funzione della distanza di applicazione  $L$  rispetto alla battuta dell'albero.

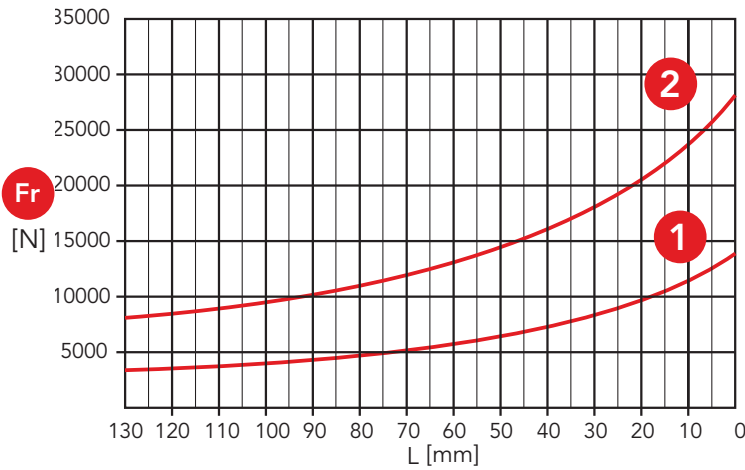

The hereunder table shows the allowable radial loads  $F_r$  (N) on the output shaft with reference to the distance  $L$ .

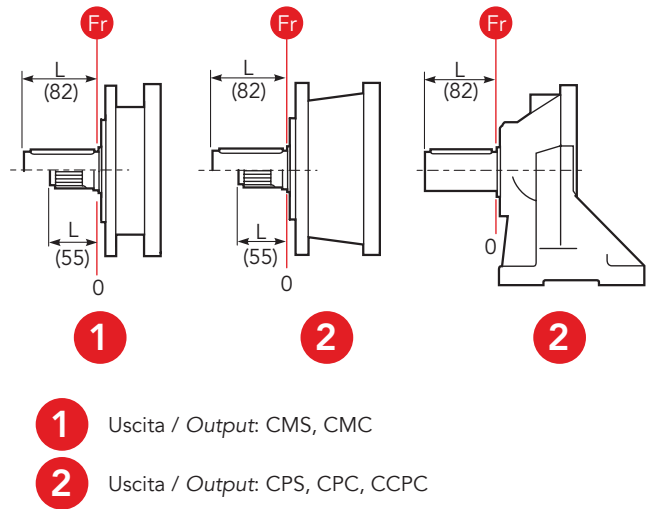

CHPL/CHPLB 1000

## CARICHI ASSIALI ( $F_a$ )

Nella tabella seguente sono indicati i carichi assiali  $F_a$  (N) applicabili sull'albero di uscita in funzione della direzione di applicazione del carico e della versione.

	<b>1</b>	<b>2</b>	
<b><math>F_a</math></b> [N]	16000	18000	
	16000	18000	

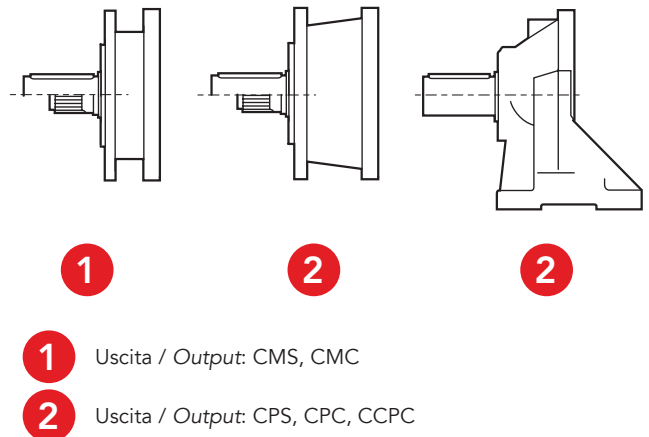

The hereunder table shows the allowable axial loads  $F_a$  (N) on the output shaft with reference to the load direction and the output type.





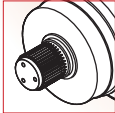
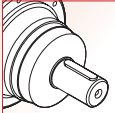
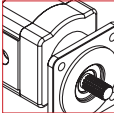
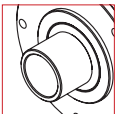
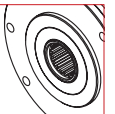
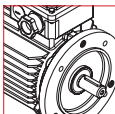
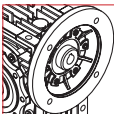

# CHPL/CHPLB 1600

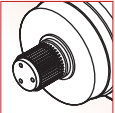
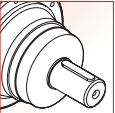
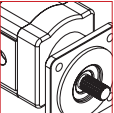
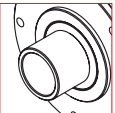
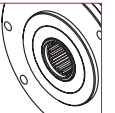
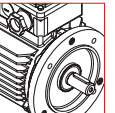
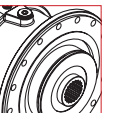

	<b>i</b>	<b>T<sub>2n</sub></b> (daNm)	<b>OUT</b>		<b>IN</b>	
<b>1601</b>	3.56 ÷ 6.75	73.2 ÷ 124.5	 Ø42	 40X36 DIN 5482	 Ø42	 Hydraulic Motor
<b>1602</b>	12.6 ÷ 58.5	73.2 ÷ 124.5	 Ø50	 40X36 DIN 5482	 Electric Motor	 Worm gearboxes
<b>1603</b>	54.2 ÷ 394.9	73.2 ÷ 124.5				
<b>1604</b>	337.4 ÷ 3422.2	73.2 ÷ 124.5			 Brake	

	<b>i</b>	<b>T<sub>2n</sub></b> (daNm)	<b>OUT</b>		<b>IN</b>	
<b>1602</b>	10.4 ÷ 19.8	73.2 ÷ 124.5	 Ø42	 40X36 DIN 5482	 Ø42	 Hydraulic Motor
<b>1603</b>	37.1 ÷ 171.6	73.2 ÷ 124.5	 Ø50	 40X36 DIN 5482	 Electric Motor	
<b>1604</b>	131.8 ÷ 1487.2	73.2 ÷ 124.5			 Brake	

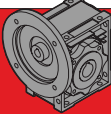

## DATI TECNICI

## TECHNICAL DATA

CHPL	i	$T_{2n}$	$P_{1n}$	$P_t$	IEC		
		( $n_1=1400$ rpm)	( $n_1=1400$ rpm)				
1601	3.56	124.5	51.2	12	63   71 80   90 100   112 132   160	CHM 50 CHM 63 CHM 75	CM42
	4.29	124.5	42.5				
	5.6	88.4	23.1				
	6.75	73.2	15.9				
1602	12.6	124.5	14.5	8	63   71 80   90 100   112 132	CHM 50 CHM 63 CHM 75	CM42
	15.2	124.5	12.0				
	19.9	124.5	9.2				
	24	124.5	7.6				
	28.9	124.5	6.3				
	31.4	88.4	4.1				
	37.8	88.4	3.4				
	45.6	73.2	2.4				
	58.5	73.2	1.8				
	1603	54.2	124.5				
65.3		124.5	2.8				
70.8		124.5	2.6				
78.7		124.5	2.3				
85.3		124.5	2.1				
102.9		124.5	1.8				
111.5		124.5	1.6				
134.4		124.5	1.4				
162		124.5	1.1				
172.6		124.5	1.1				
208		124.5	0.88				
211.7		88.4	0.61				
255.2		88.4	0.51				
271.8		88.4	0.48				
307.5		73.2	0.35				
327.6		88.4	0.40				
394.9	73.2	0.27					
1604	337.4	124.5	0.54	1.5	63   71 80   90	CHM 50 CHM 63 CHM 75	CM42
	365.7	124.5	0.50				
	396.4	124.5	0.46				
	440.8	124.5	0.41				
	477.9	124.5	0.38				
	531.3	124.5	0.34				
	576	124.5	0.32				
	624.4	124.5	0.29				
	694.3	124.5	0.26				
	752.6	124.5	0.24				
	836.9	124.5	0.22				
	907.2	124.5	0.20				
	966.3	124.5	0.19				
	1093.5	124.5	0.17				
	1144.5	124.5	0.16				
	1185.4	88.4	0.11				
	1318.1	124.5	0.14				
1428.8	88.4	0.09					
1692.3	124.5	0.11					
3422.2	73.2	0.03					

 $n_{1max} = 2800$  rpm





## DATI TECNICI

## TECHNICAL DATA

 CHPLB	i	T <sub>2n</sub> (n <sub>1</sub> =1400 rpm)	P <sub>1n</sub> (n <sub>1</sub> =1400 rpm)	P <sub>t</sub> [kW]	IEC		 CM
		[daNm]	[kW]		(B5)		
<b>1602</b>	10.4	124.5	17.5	8	63 80 100 132	71 90 112	CM42
	12.6	124.5	14.5				
	16.4	88.4	7.9				
	19.8	73.2	5.4				
<b>1603</b>	37.1	124.5	4.9	5	63 80 100 132	71 90 112	CM42
	44.7	124.5	4.1				
	53.9	124.5	3.4				
	58.4	124.5	3.1				
	70.4	124.5	2.6				
	84.9	124.5	2.1				
	92	88.4	1.4				
	110.9	88.4	1.2				
	133.6	73.2	0.8				
	171.6	73.2	0.6				
<b>1604</b>	131.8	124.5	1.4	1.5	63 80	71 90	CM42
	158.9	124.5	1.1				
	191.6	124.5	1.0				
	207.7	124.5	0.9				
	230.9	124.5	0.8				
	301.7	124.5	0.6				
	327.1	124.5	0.6				
	363.7	124.5	0.50				
	394.2	124.5	0.46				
	475.2	124.5	0.38				
	515.1	88.4	0.25				
	572.8	124.5	0.32				
	610.1	124.5	0.30				
	735.4	124.5	0.25				
	797.2	88.4	0.16				
	960.9	88.4	0.13				
1158.3	73.2	0.09					
1233.8	88.4	0.10					
1487.2	73.2	0.07					

n<sub>1max</sub> = 2800 rpm

CHPL/CHPLB 1600



## DIMENSIONI CMS

## CMS DIMENSIONS

### CHPL 1600 CMS - Flange motori IEC

### CHPL 1600 CMS- IEC Motor flanges

CHPL	IEC 63			IEC 71			IEC 80			IEC 90		
	LP	P	ØD	LP	P	ØD	LP	P	ØD	LP	P	ØD
1601	153	36	140	153	36	160	173	56	200	173	56	200
1602	201			201			221			221		
1603	249			249			269			269		
1604	297			297			317			317		

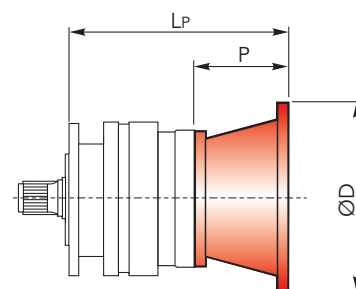

CHPL	IEC 100			IEC 112			IEC 132			IEC 160		
	LP	P	ØD	LP	P	ØD	LP	P	ØD	LP	P	ØD
1601	183	66	250	183	66	250	217	100	300	256	139	350
1602	231			231			265			-		
1603	279			266			313			-		
1604	-			-			-			-		

### CHPL 1600 CMS - Alberi maschi entrata

### CHPL 1600 CMS - Male input shafts

CHPL	CM42			
	LT	T	LE	ØE
1601	210	93	82	42 h6
1602	258			
1603	306			
1604	354			

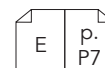
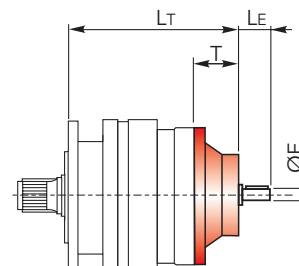



## DIMENSIONI CMS

## CMS DIMENSIONS

CHPL/CHPLB 1600

CHPL 1600 CMS - Riduttore a vite senza fine CHM in entrata CHPL 1600 CMS - CHM input worm gearboxes

CHPL	CHM 50					CHM 63				
	Lv	I	H	M	N	Lv	I	H	M	N
1601	242.5	50	110	60	80	252	63	135	72	95
1602	290.5					300				
1603	338.5					348				
1604	386.5					396				

CHPL	CHM 75				
	Lv	I	H	M	N
1601	231	75	161	86	112.5
1602	279				
1603	327				
1604	375				

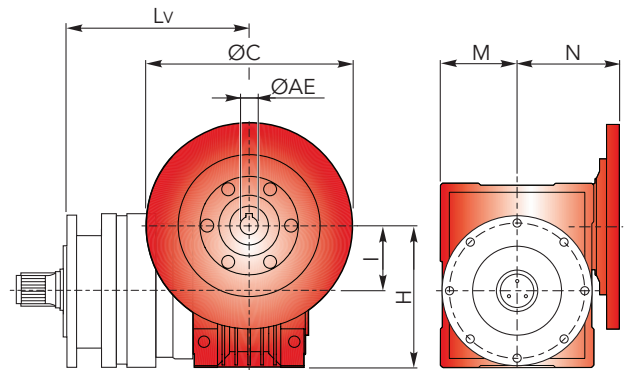

CHPLB 1600 CMS - Flange motori IEC

CHPLB 1600 CMS - IEC Motor flanges

CHPLB	IEC 63				IEC 71				IEC 80				IEC 90			
	L	LP	P	ØD	L	LP	P	ØD	L	LP	P	ØD	L	LP	P	ØD
1602	192	196	36	140	192	196	36	160	192	216	56	200	192	216	56	200
1603	240				240				240				240			
1604	288				288				288				288			

CHPLB	IEC 100				IEC 112				IEC 132				
	L	LP	P	ØD	L	LP	P	ØD	L	LP	P	ØD	
1602	192	226	66	250	192	226	66	250	192	260	100	300	
1603	240				240				240				240
1604	-				-				-				-

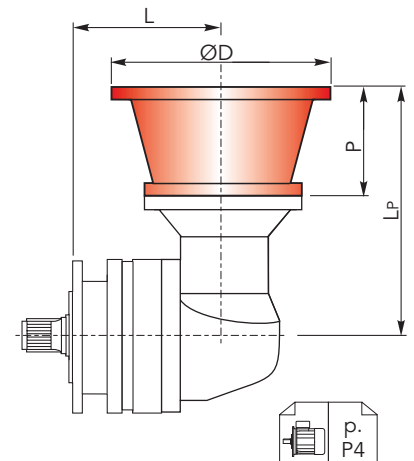

CHPLB 1600 CMS - Alberi maschi entrata

CHPL 1600 CMS - Male input shafts

CHPLB	CM42				
	L	L <sub>T</sub>	T	L <sub>E</sub>	ØE
1602	192	253	93	82	42 h6
1603	240				
1604	288				

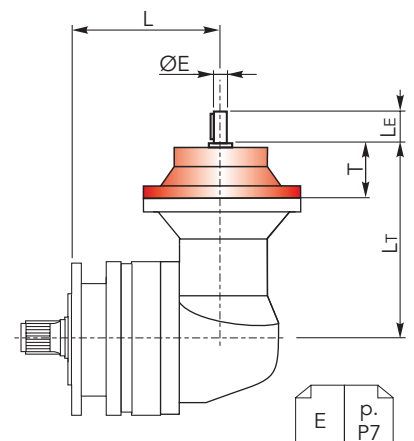



## DIMENSIONI CMC

## CMC DIMENSIONS

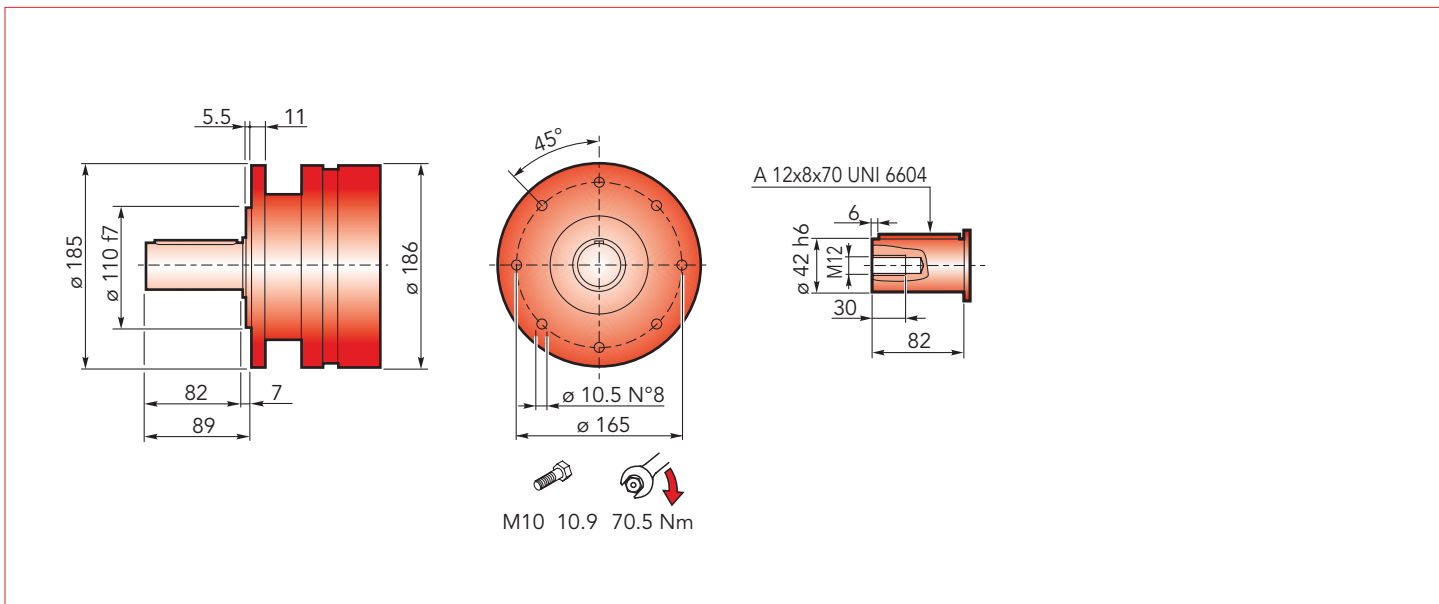

### CHPL 1600 CMC - Flange motori IEC

### CHPL 1600 CMC- IEC Motor flanges

CHPL	IEC 63			IEC 71			IEC 80			IEC 90		
	LP	P	ØD	LP	P	ØD	LP	P	ØD	LP	P	ØD
1601	153	36	140	153	36	160	173	56	200	173	56	200
1602	201			201			221			221		
1603	249			249			269			269		
1604	297			297			317			317		

CHPL	IEC 100			IEC 112			IEC 132			IEC 160		
	LP	P	ØD	LP	P	ØD	LP	P	ØD	LP	P	ØD
1601	183	66	250	183	66	250	217	100	300	256	139	350
1602	231			231			265			-	-	-
1603	279			266			313			-	-	-
1604	-			-			-			-	-	-

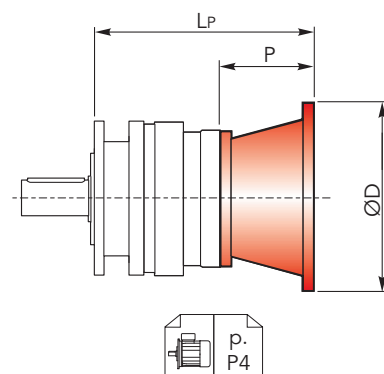

### CHPL 1600 CMC - Alberi maschi entrata

### CHPL 1600 CMC - Male input shafts

CHPL	CM42			
	LT	T	LE	ØE
1601	210	93	82	42 h6
1602	258			
1603	306			
1604	354			

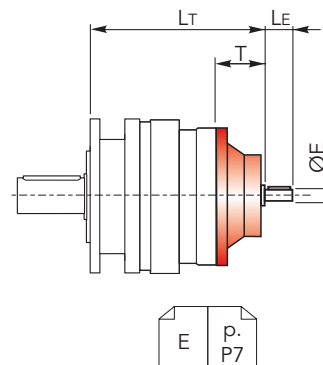



## DIMENSIONI CMC

## CMC DIMENSIONS

CHPL 1600 CMC - Riduttore a vite senza fine CHM in entrata CHPL 1600 CMC - CHM input worm gearboxes

CHPL	CHM 50					CHM 63				
	Lv	I	H	M	N	Lv	I	H	M	N
1601	242.5	50	110	60	80	252	63	135	72	95
1602	290.5					300				
1603	338.5					348				
1604	386.5					396				

CHPL	CHM 75				
	Lv	I	H	M	N
1601	231	75	161	86	112.5
1602	279				
1603	327				
1604	375				

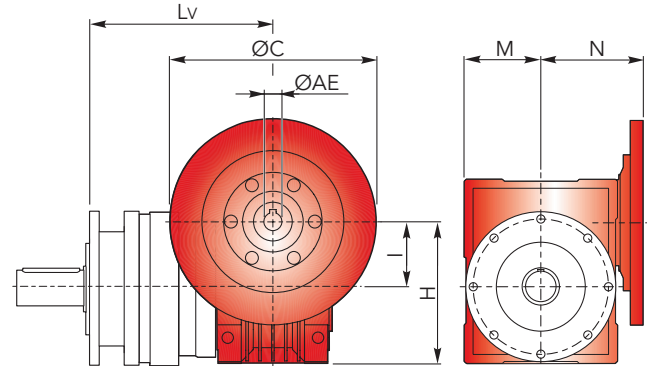

CHPLB 1600 CMC - Flange motori IEC

CHPLB 1600 CMC - IEC Motor flanges

CHPLB	IEC 63				IEC 71				IEC 80				IEC 90						
	L	LP	P	ØD	L	LP	P	ØD	L	LP	P	ØD	L	LP	P	ØD			
1602	192	196	36	140	192	196	36	160	192	216	56	200	192	216	56	200			
1603	240				240				240				240				240	240	240
1604	288				288				288				288				288	288	288

CHPLB	IEC 100				IEC 112				IEC 132				
	L	LP	P	ØD	L	LP	P	ØD	L	LP	P	ØD	
1602	192	226	66	250	192	226	66	250	192	260	100	300	
1603	240				240				240				240
1604	-				-				-				-

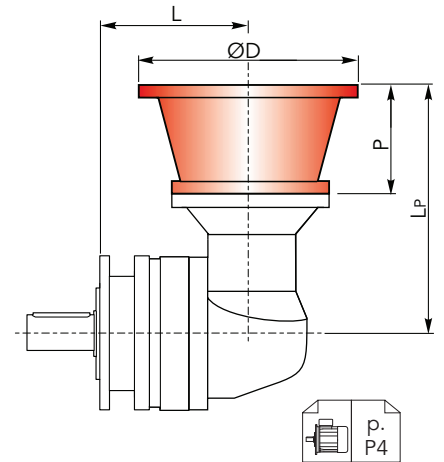

CHPLB 1600 CMC - Alberi maschi entrata

CHPL 1600 CMC - Male input shafts

CHPLB	CM42				
	L	LT	T	LE	ØE
1602	192	253	93	82	42 h6
1603	240				
1604	288				

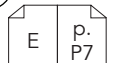
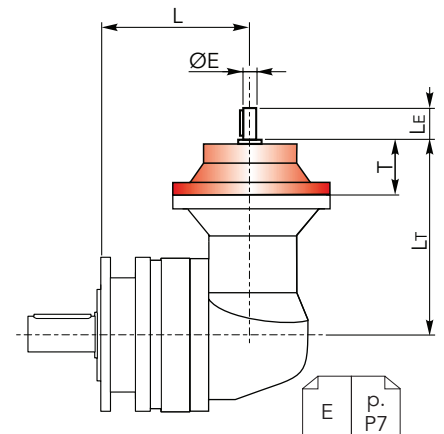



## DIMENSIONI CPS

## CPS DIMENSIONS

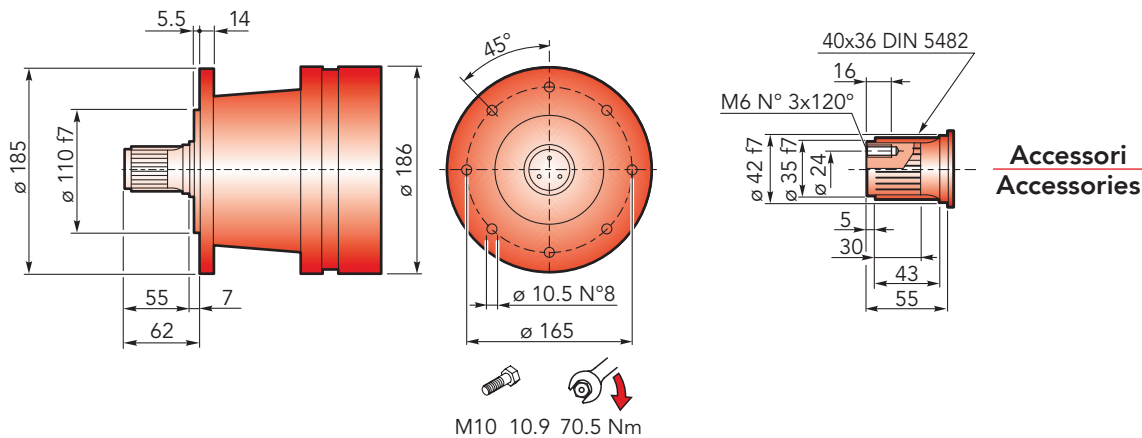

## CHPL 1600 CPS - Flange motori IEC

## CHPL 1600 CPS- IEC Motor flanges

CHPL	IEC 63			IEC 71			IEC 80			IEC 90		
	LP	P	ØD	LP	P	ØD	LP	P	ØD	LP	P	ØD
1601	183			183			203			203		
1602	231	36	140	231	36	160	251	56	200	251	56	200
1603	279			279			299			299		
1604	327			327			347			347		

CHPL	IEC 100			IEC 112			IEC 132			IEC 160		
	LP	P	ØD	LP	P	ØD	LP	P	ØD	LP	P	ØD
1601	213			213			247			286	139	350
1602	261	66	250	261	66	250	295	100	300	-		
1603	309			309			343			-		
1604	-			-			-			-		

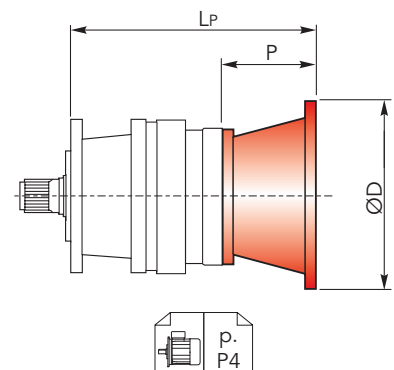

## CHPL 1600 CPS - Alberi maschi entrata

## CHPL 1600 CPS - Male input shafts

CHPL	CM42			
	LT	T	LE	ØE
1601	240			
1602	288	93	82	42 h6
1603	336			
1604	384			

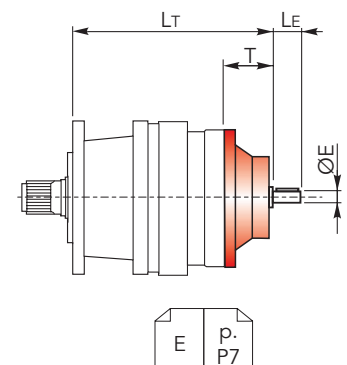



## DIMENSIONI CPS

## CPS DIMENSIONS

CHPL/CHPLB 1600

CHPL 1600 CPS - Riduttore a vite senza fine CHM in entrata

CHPL 1600 CPS - CHM input worm gearboxes

CHPL	CHM 50					CHM 63				
	Lv	I	H	M	N	Lv	I	H	M	N
1601	272.5	50	110	60	80	282	63	135	72	95
1602	320.5					330				
1603	368.5					378				
1604	416.5					426				

CHPL	CHM 75				
	Lv	I	H	M	N
1601	261	75	161	86	112.5
1602	309				
1603	357				
1604	405				

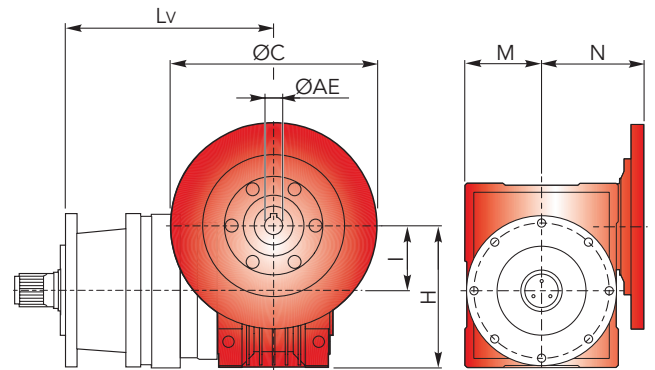

CHPLB 1600 CPS - Flange motori IEC

CHPLB 1600 CPS - IEC Motor flanges

CHPLB	IEC 63				IEC 71				IEC 80				IEC 90			
	L	LP	P	ØD	L	LP	P	ØD	L	LP	P	ØD	L	LP	P	ØD
1602	222	196	36	140	222	196	36	160	222	216	56	200	222	216	56	200
1603	270				270				270							
1604	318				318				318							

CHPLB	IEC 100				IEC 112				IEC 132			
	L	LP	P	ØD	L	LP	P	ØD	L	LP	P	ØD
1602	222	226	66	250	222	226	66	250	222	260	100	300
1603	270				270				270			
1604	-				-				-			

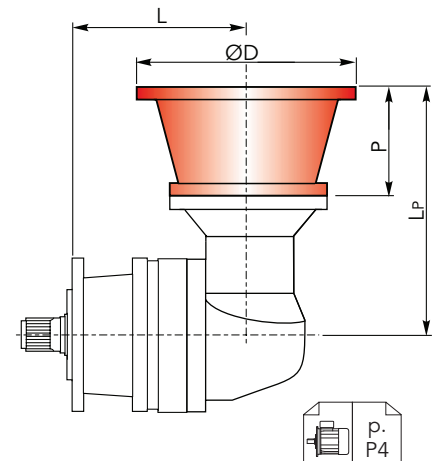

CHPLB 1600 CPS - Alberi maschi entrata

CHPL 1600 CPS - Male input shafts

CHPLB	CM42				
	L	L <sub>T</sub>	T	L <sub>E</sub>	ØE
1602	222	253	93	82	42 h6
1603	270				
1604	318				

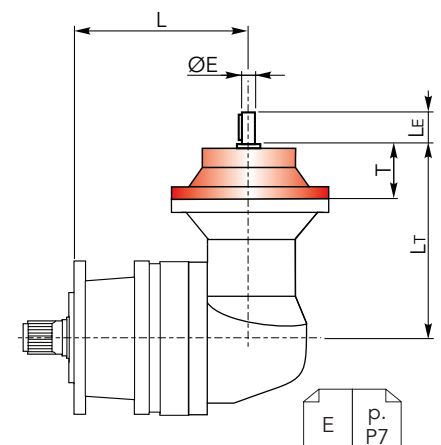



## DIMENSIONI CPC

## CPC DIMENSIONS

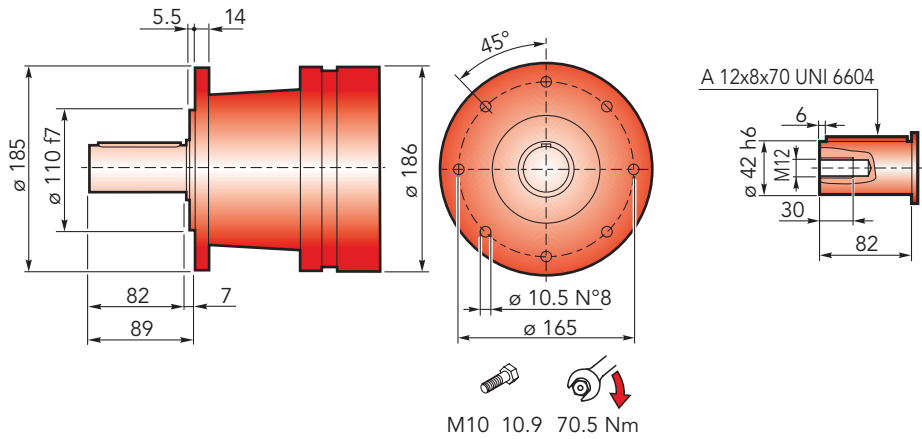

## CHPL 1600 CPC - Flange motori IEC

## CHPL 1600 CPC- IEC Motor flanges

CHPL	IEC 63			IEC 71			IEC 80			IEC 90		
	LP	P	ØD	LP	P	ØD	LP	P	ØD	LP	P	ØD
1601	183			183			203			203		
1602	231	36	140	231	36	160	251	56	200	251	56	200
1603	279			279			299			299		
1604	327			327			347			347		

CHPL	IEC 100			IEC 112			IEC 132			IEC 160		
	LP	P	ØD	LP	P	ØD	LP	P	ØD	LP	P	ØD
1601	213			213			247			286	139	350
1602	261	66	250	261	66	250	295	100	300	-		
1603	309			309			343			-		
1604	-			-			-			-		

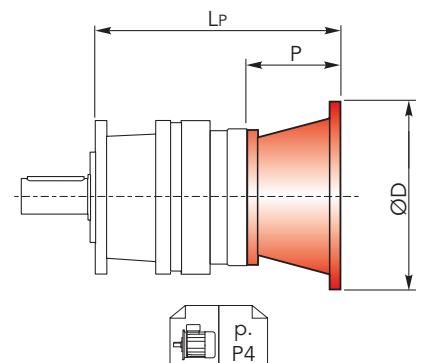

## CHPL 1600 CPC - Alberi maschi entrata

## CHPL 1600 CPC - Male input shafts

CHPL	CM42			
	LT	T	LE	ØE
1601	240			
1602	288	93	82	42 h6
1603	336			
1604	384			

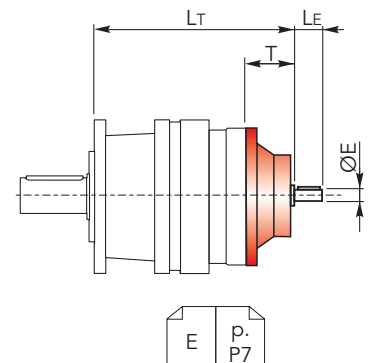





## DIMENSIONI CPC

## CPC DIMENSIONS

CHPL/CHPLB 1600

CHPL 1600 CPC - Riduttore a vite senza fine CHM in entrata

CHPL 1600 CPC - CHM input worm gearboxes

CHPL	CHM 50					CHM 63				
	Lv	I	H	M	N	Lv	I	H	M	N
1601	272.5	50	110	60	80	282	63	135	72	95
1602	320.5					330				
1603	368.5					378				
1604	416.5					426				

CHPL	CHM 75				
	Lv	I	H	M	N
1601	261	75	161	86	112.5
1602	309				
1603	357				
1604	405				

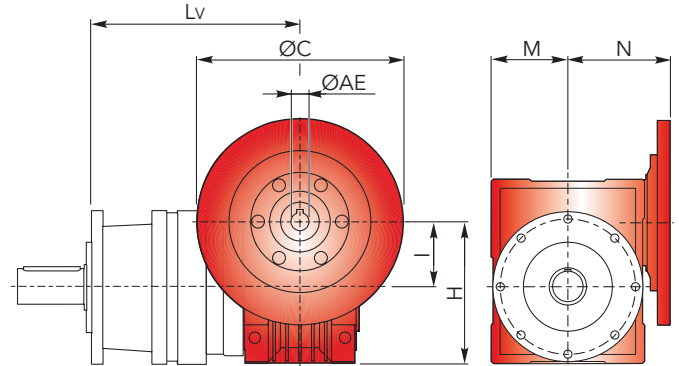

ØC p.  
ØAE P6

CHPLB 1600 CPC - Flange motori IEC

CHPLB 1600 CPC - IEC Motor flanges

CHPLB	IEC 63				IEC 71				IEC 80				IEC 90			
	L	LP	P	ØD	L	LP	P	ØD	L	LP	P	ØD	L	LP	P	ØD
1602	222	196	36	140	222	196	36	160	222	216	56	200	222	216	56	200
1603	270				270				270							
1604	318				318				318							

CHPLB	IEC 100				IEC 112				IEC 132			
	L	LP	P	ØD	L	LP	P	ØD	L	LP	P	ØD
1602	222	226	66	250	222	226	66	250	222	260	100	300
1603	270				270				270			
1604	-				-				-			

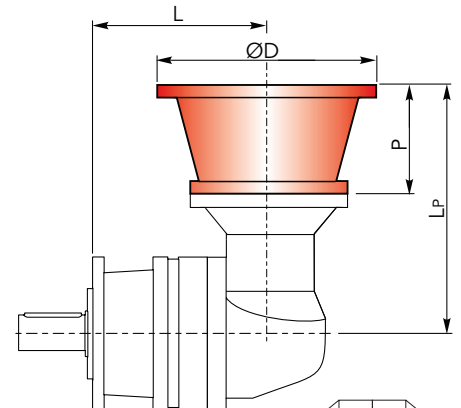

p.  
P4

CHPLB 1600 CPC - Alberi maschi entrata

CHPL 1600 CPC - Male input shafts

CHPLB	CM42				
	L	L <sub>T</sub>	T	L <sub>E</sub>	ØE
1602	222	253	93	82	42 h6
1603	270				
1604	318				

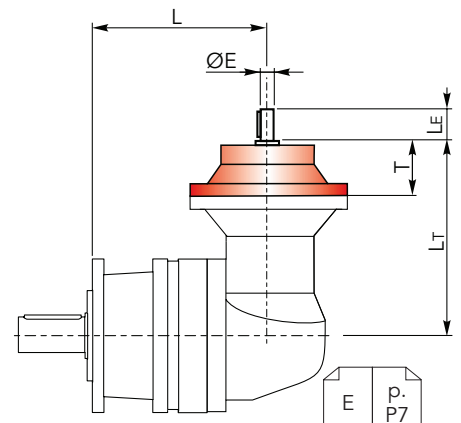

E p.  
P7



## DIMENSIONI CF

## CF DIMENSIONS

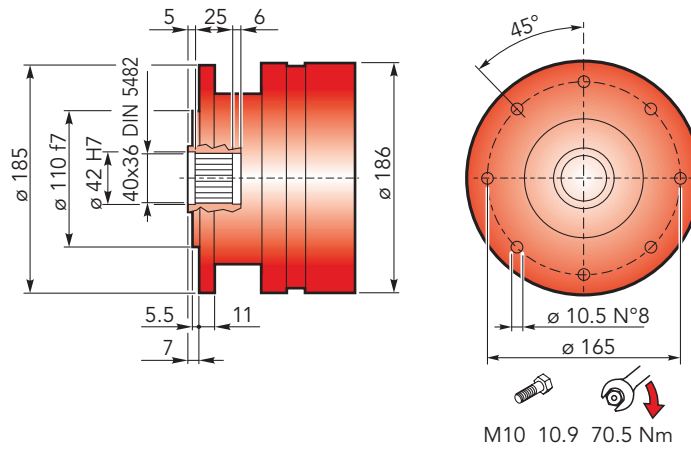

Accessori  
Accessories

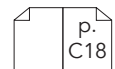

### CHPL 1600 CF - Flange motori IEC

### CHPL 1600 CF- IEC Motor flanges

CHPL	IEC 63			IEC 71			IEC 80			IEC 90		
	LP	P	ØD	LP	P	ØD	LP	P	ØD	LP	P	ØD
1601	153	36	140	153	36	160	173	56	200	173	56	200
1602	201			201			221					
1603	249			249			269					
1604	297			297			317					

CHPL	IEC 100			IEC 112			IEC 132			IEC 160		
	LP	P	ØD	LP	P	ØD	LP	P	ØD	LP	P	ØD
1601	183	66	250	183	66	250	217	100	300	256	139	350
1602	231			231			265			-		
1603	279			266			313			-		
1604	-			-			-			-		

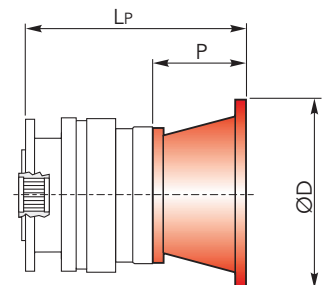

### CHPL 1600 CF - Alberi maschi entrata

### CHPL 1600 CF - Male input shafts

CHPL	CM42			
	LT	T	LE	ØE
1601	210	93	82	42 h6
1602	258			
1603	306			
1604	354			

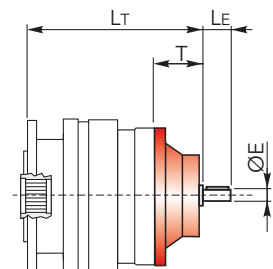



## DIMENSIONI CF

## CF DIMENSIONS

CHPL/CHPLB 1600

CHPL 1600 CF - Riduttore a vite senza fine CHM in entrata

CHPL 1600 CF - CHM input worm gearboxes

CHPL	CHM 50					CHM 63				
	Lv	I	H	M	N	Lv	I	H	M	N
1601	242.5	50	110	60	80	252	63	135	72	95
1602	290.5					300				
1603	338.5					348				
1604	386.5					396				

CHPL	CHM 75				
	Lv	I	H	M	N
1601	231	75	161	86	112.5
1602	279				
1603	327				
1604	375				

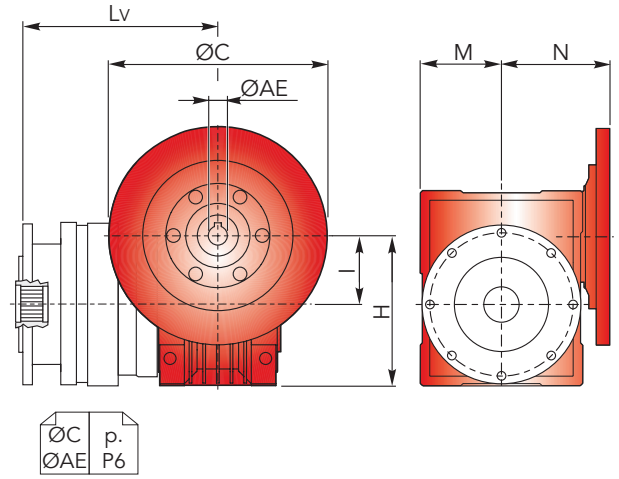

CHPLB 1600 CF - Flange motori IEC

CHPLB 1600 CF - IEC Motor flanges

CHPLB	IEC 63				IEC 71				IEC 80				IEC 90			
	L	LP	P	ØD	L	LP	P	ØD	L	LP	P	ØD	L	LP	P	ØD
1602	192	196	36	140	192	196	36	160	192	216	56	200	192	216	56	200
1603	240				240				240							
1604	288				288				288							

CHPLB	IEC 100				IEC 112				IEC 132			
	L	LP	P	ØD	L	LP	P	ØD	L	LP	P	ØD
1602	192	226	66	250	192	226	66	250	192	260	100	300
1603	240				240				240			
1604	-				-				-			

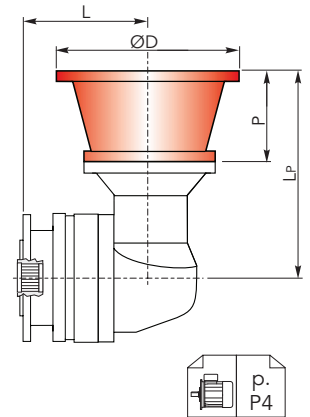

CHPLB 1600 CF - Alberi maschi entrata

CHPL 1600 CF - Male input shafts

CHPLB	CM42				
	L	LT	T	LE	ØE
1602	192	253	93	82	42 h6
1603	240				
1604	288				

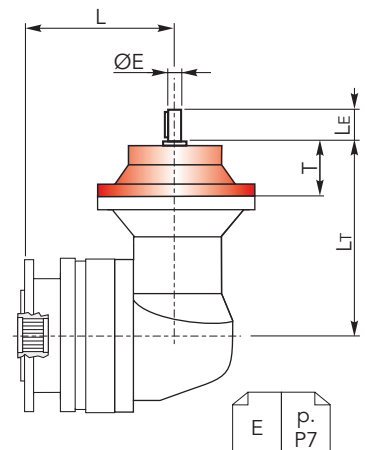



## DIMENSIONI CFS

## CFS DIMENSIONS

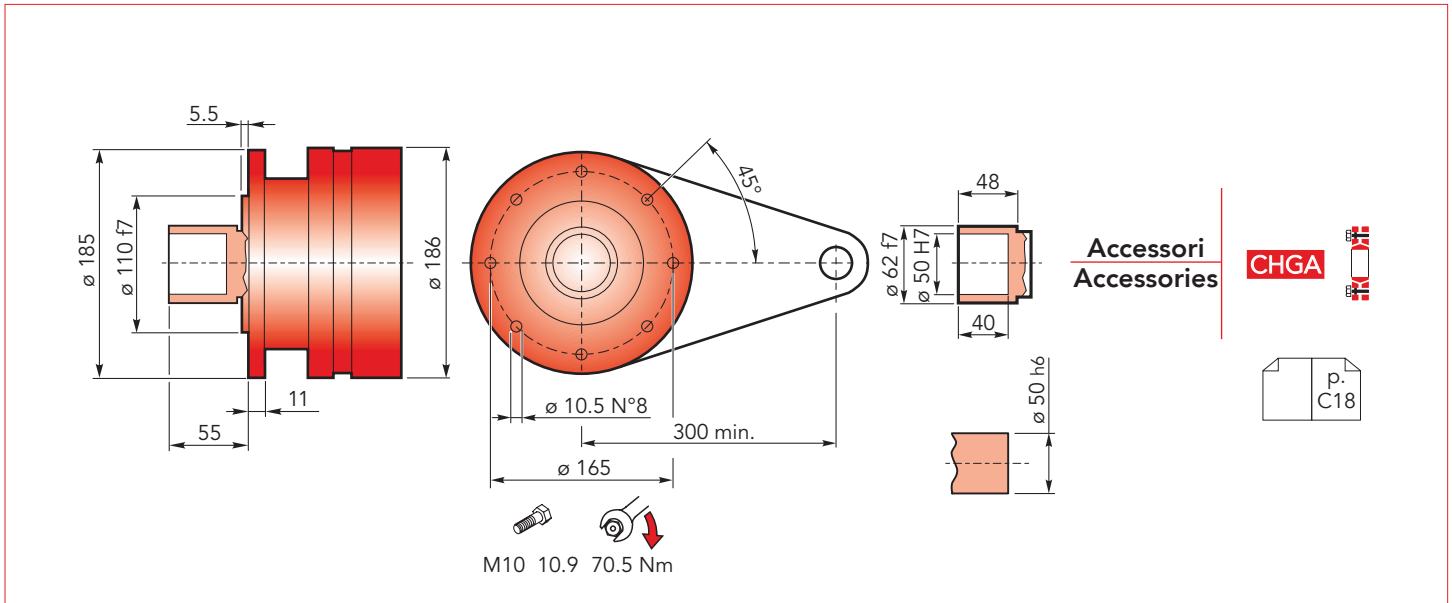

## CHPL 1600 CFS - Flange motori IEC

## CHPL 1600 CFS- IEC Motor flanges

CHPL	IEC 63			IEC 71			IEC 80			IEC 90			
	LP	P	ØD	LP	P	ØD	LP	P	ØD	LP	P	ØD	
1601	153			153			173			173			
1602	201	36	140	201	36	160	221	56	200	221	56	200	
1603	249			249			269			269			269
1604	297			297			317			317			317

CHPL	IEC 100			IEC 112			IEC 132			IEC 160		
	LP	P	ØD	LP	P	ØD	LP	P	ØD	LP	P	ØD
1601	183			183			217			256	139	350
1602	231	66	250	231	66	250	265	100	300	-		
1603	279			266			313			-		
1604	-			-			-			-		

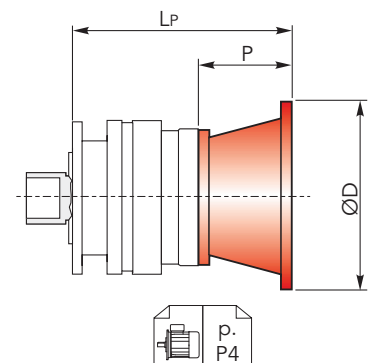

## CHPL 1600 CFS - Alberi maschi entrata

## CHPL 1600 CFS - Male input shafts

CHPL	CM42			
	LT	T	LE	ØE
1601	210			
1602	258	93	82	42 h6
1603	306			
1604	354			

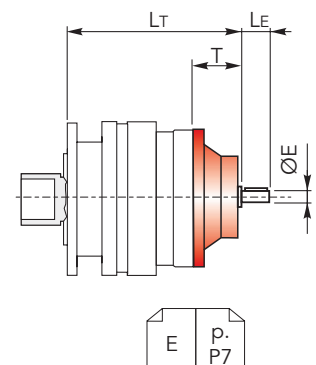



## DIMENSIONI CFS

## CFS DIMENSIONS

CHPL/CHPLB 1600

CHPL 1600 CFS - Riduttore a vite senza fine CHM in entrata

CHPL 1600 CFS - CHM input worm gearboxes

CHPL	CHM 50					CHM 63				
	Lv	I	H	M	N	Lv	I	H	M	N
1601	242.5	50	110	60	80	252	63	135	72	95
1602	290.5					300				
1603	338.5					348				
1604	386.5					396				

CHPL	CHM 75				
	Lv	I	H	M	N
1601	231	75	161	86	112.5
1602	279				
1603	327				
1604	375				

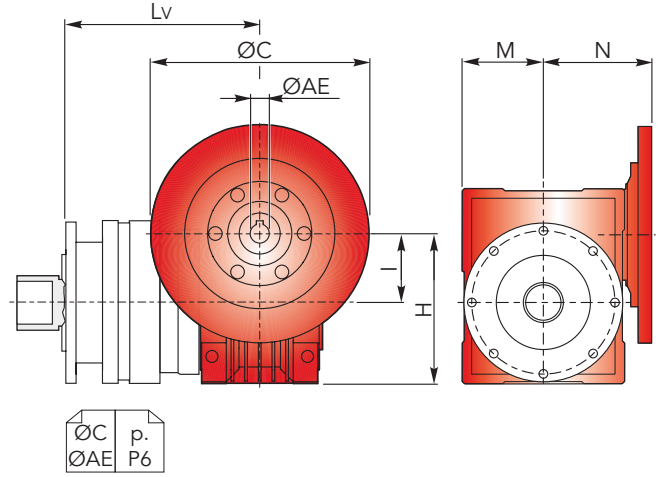

CHPLB 1600 CFS - Flange motori IEC

CHPLB 1600 CFS - IEC Motor flanges

CHPLB	IEC 63				IEC 71				IEC 80				IEC 90						
	L	LP	P	ØD	L	LP	P	ØD	L	LP	P	ØD	L	LP	P	ØD			
1602	192	196	36	140	192	196	36	160	192	216	56	200	192	216	56	200			
1603	240				240				240				240				240	240	240
1604	288				288				288				288				288	288	288

CHPLB	IEC 100				IEC 112				IEC 132				
	L	LP	P	ØD	L	LP	P	ØD	L	LP	P	ØD	
1602	192	226	66	250	192	226	66	250	192	260	100	300	
1603	240				240				240				240
1604	-				-				-				-

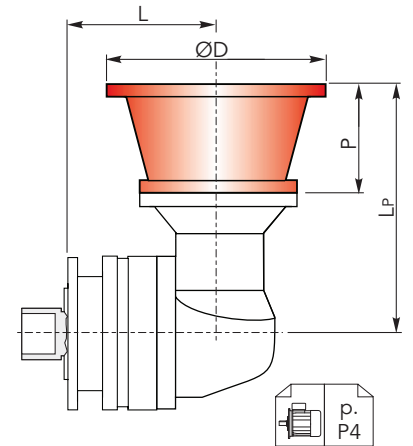

CHPLB 1600 CFS - Alberi maschi entrata

CHPL 1600 CFS - Male input shafts

CHPLB	CM42				
	L	L <sub>T</sub>	T	L <sub>E</sub>	ØE
1602	192	253	93	82	42 h6
1603	240				
1604	288				

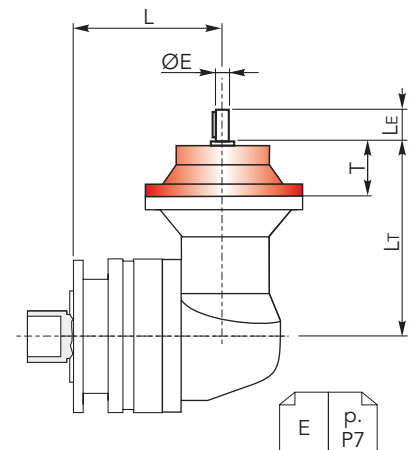



**DIMENSIONI CCPC**

**CCPC DIMENSIONS**

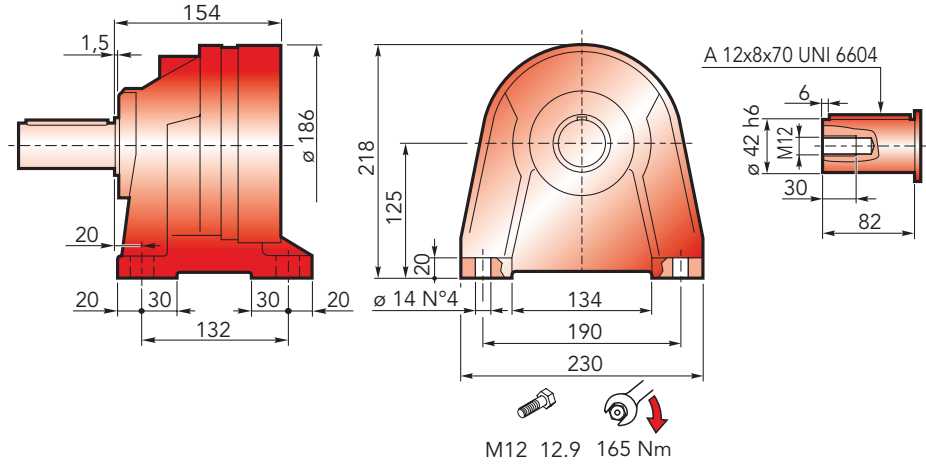

**CHPL 1600 CCPC - Flange motori IEC**

**CHPL 1600 CCPC- IEC Motor flanges**

CHPL	IEC 63			IEC 71			IEC 80			IEC 90		
	L <sub>P</sub>	P	ØD	L <sub>P</sub>	P	ØD	L <sub>P</sub>	P	ØD	L <sub>P</sub>	P	ØD
1601	190	36	140	190	36	160	210	56	200	210	56	200
1602	238			238			258					
1603	286			286			306					
1604	334			334			354					

CHPL	IEC 100			IEC 112			IEC 132			IEC 160		
	L <sub>P</sub>	P	ØD	L <sub>P</sub>	P	ØD	L <sub>P</sub>	P	ØD	L <sub>P</sub>	P	ØD
1601	220	66	250	220	66	250	254	100	300	293	139	350
1602	268			268			302			-		
1603	316			316			350			-		
1604	-			-			-			-		

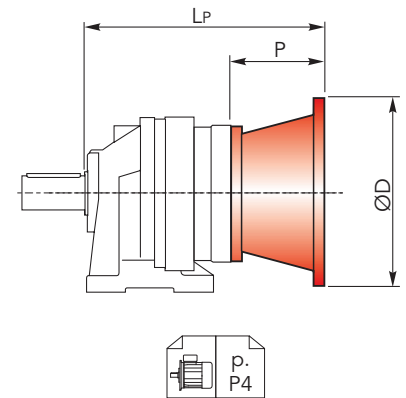

**CHPL 1600 CCPC - Alberi maschi entrata**

**CHPL 1600 CCPC - Male input shafts**

CHPL	CM42			
	L <sub>T</sub>	T	L <sub>E</sub>	ØE
1601	247	93	82	42 h6
1602	295			
1603	343			
1604	391			

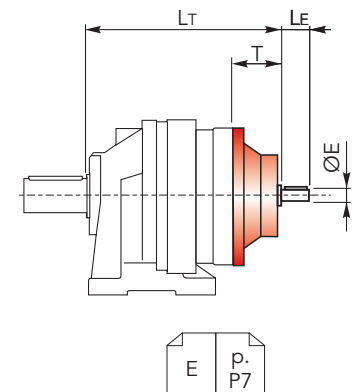



## DIMENSIONI CCPC

## CCPC DIMENSIONS

CHPL/CHPLB 1600

CHPL 1600 CCPC - Riduttore a vite senza fine CHM in entrata CHPL 1600 CCPC - CHM input worm gearboxes

CHPL	CHM 50					CHM 63				
	Lv	I	H	M	N	Lv	I	H	M	N
1601	279.5	50	110	60	80	289	63	135	72	95
1602	327.5					337				
1603	375.5					385				
1604	423.5					433				

CHPL	CHM 75				
	Lv	I	H	M	N
1601	268	75	161	86	112.5
1602	316				
1603	364				
1604	412				

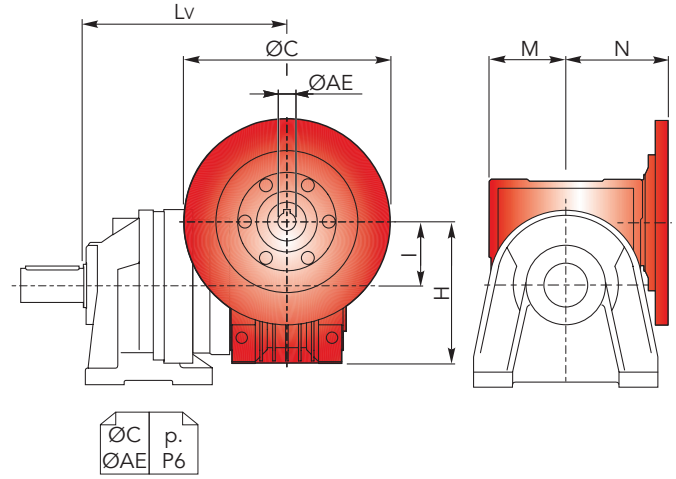

CHPLB 1600 CCPC - Flange motori IEC

CHPLB 1600 CCPC - IEC Motor flanges

CHPLB	IEC 71				IEC 71				IEC 80				IEC 90			
	L	LP	P	ØD	L	LP	P	ØD	L	LP	P	ØD	L	LP	P	ØD
1602	229	196	36	140	229	196	36	160	229	216	56	200	229	216	56	200
1603	277				277				277							
1604	325				325				325							

CHPLB	IEC 100				IEC 112				IEC 132			
	L	LP	P	ØD	L	LP	P	ØD	L	LP	P	ØD
1602	229	226	66	250	229	226	66	250	229	260	100	300
1603	277				277				277			
1604	-				-				-			

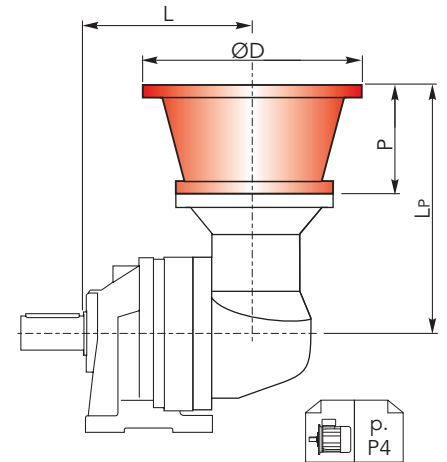

CHPLB 1600 CCPC - Alberi maschi entrata

CHPL 1600 CCPC - Male input shafts

CHPLB	CM42				
	L	LT	T	LE	ØE
1602	229	253	93	82	42 h6
1603	277				
1604	325				

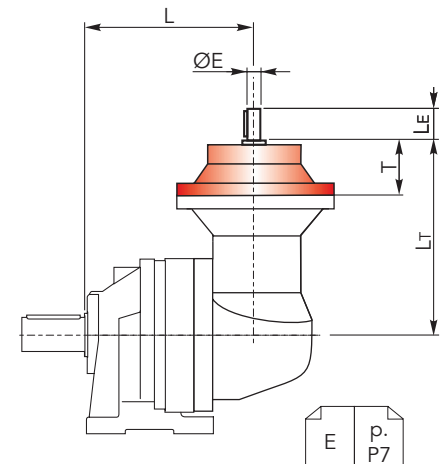



## ACCESSORI

## ACCESSORIES

CHYZ



Pignoni / Pinions

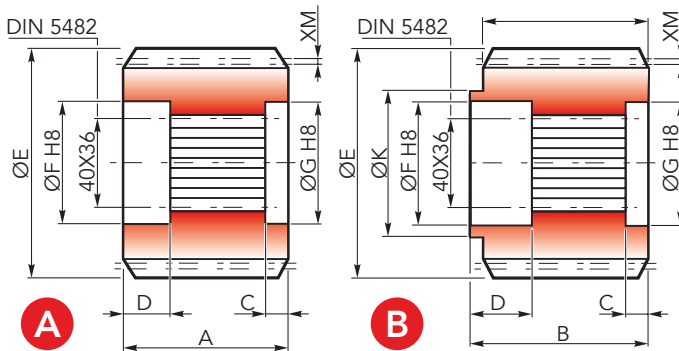

	Uscita / Output	M	Z	XM	A	B	C	D	E	F	G	K	Codice / Code
A	CMS	1.9	20	0.05	65	-	6	20.5	84.5	42	42	-	1071.200.042
	CPS	5	16	2.5	55	-	6	20.5	95	42	42	-	1071.259.042
B	CMS	3.5	23	0	40	60.5	6	20.5	87.5	42	42	60	1071.291.042

CHFF

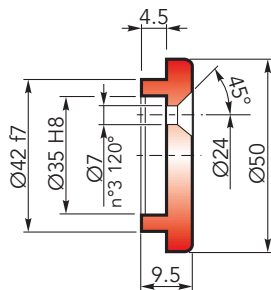

Fondello di arresto / Stop bottom plate

Codice / Code:  
1075.034.000

CHBS

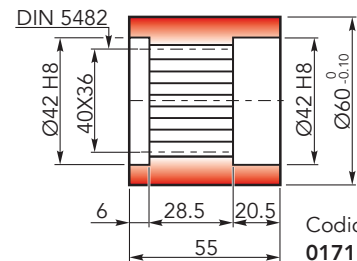

Boccola scanalata / Splined bushing

Codice / Code:  
0171.100.076

CHKB

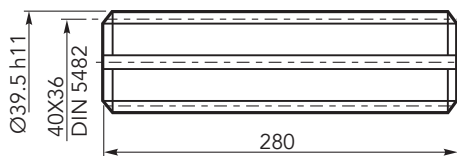

Barra scanalata / Splined rod

Codice / Code:  
3071.179.042

CHFL

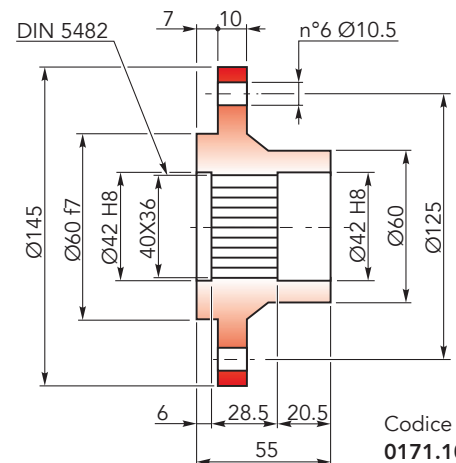

Flangia / Flange

Codice / Code:  
0171.102.025

CHGA

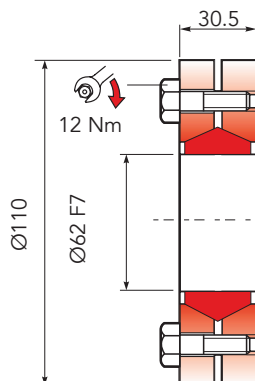

Giunto di attrito / Shrink disc

Coppia max: 2200 Nm (1)  
Max Torque: 2200 Nm (1)Codice / Code:  
5109.062.000

(1): Coppia max indicata è valida solo con calettatori forniti da Chiaravalli S.p.A.

(1): The maximum torque indicated is valid only with shrink discs supplied by Chiaravalli S.p.A.





## CARICHI RADIALI (Fr)

Nel diagramma seguente, sono indicati i carichi radiali  $F_r$  (N) applicabili sull'albero uscita in funzione della distanza di applicazione  $L$  rispetto alla battuta dell'albero.

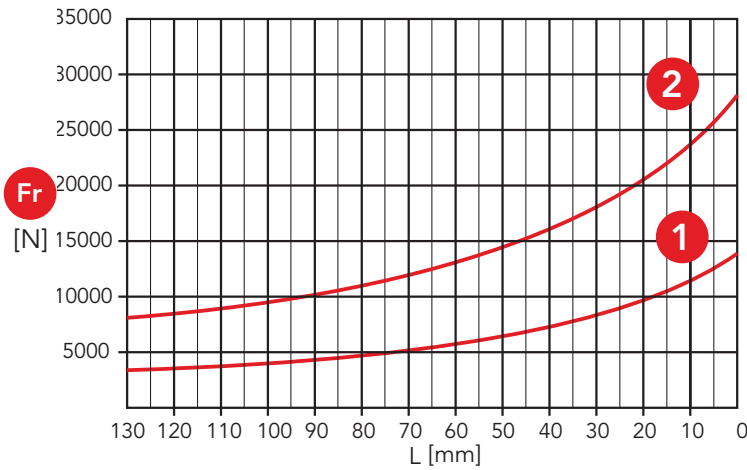

The hereunder table shows the allowable radial loads  $F_r$  (N) on the output shaft with reference to the distance  $L$ .

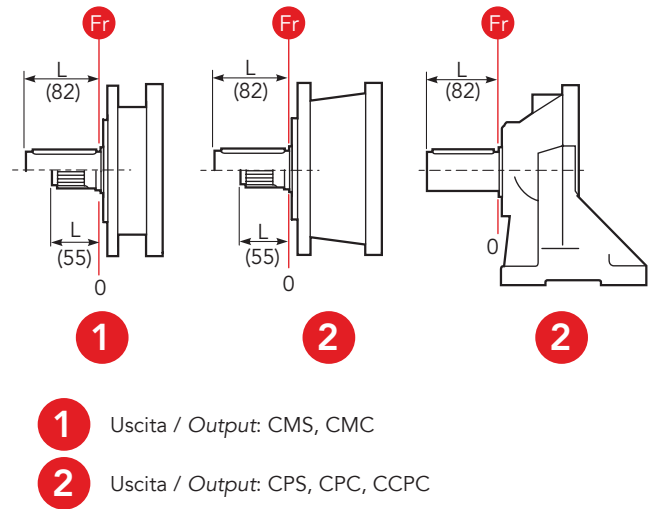

## CARICHI ASSIALI (Fa)

Nella tabella seguente sono indicati i carichi assiali  $F_a$  (N) applicabili sull'albero di uscita in funzione della direzione di applicazione del carico e della versione.

	<b>1</b>	<b>2</b>	
<b>Fa</b> [N]	16000	18000	←
	16000	18000	→

The hereunder table shows the allowable axial loads  $F_a$  (N) on the output shaft with reference to the load direction and the output type.

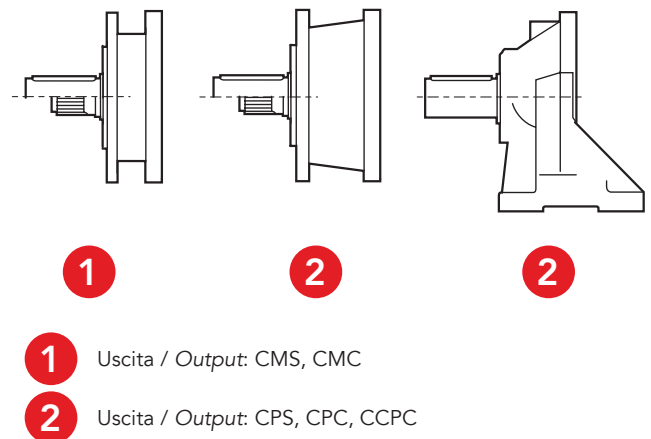



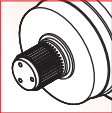
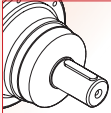
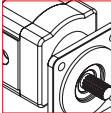
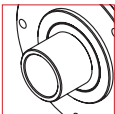
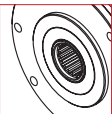
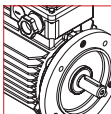
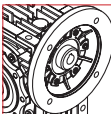
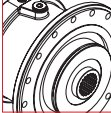

# CHPL/CHPLB 2500

	<b>i</b>	<b>T<sub>2n</sub></b> (daNm)	<b>OUT</b>		<b>IN</b>	
<b>2501</b>	3.78 ÷ 7.25	126.4 ÷ 256.5	 Ø65	 58X53 DIN 5482	 Ø42 Ø65	 Hydraulic Motor
<b>2502</b>	13.4 ÷ 62.8	126.4 ÷ 256.5	 Ø75	 58X53 DIN 5482	 Electric Motor	 Worm gearboxes
<b>2503</b>	52.1 ÷ 424.1	126.4 ÷ 256.5				
<b>2504</b>	352.0 ÷ 2369.2	162.5 ÷ 256.5			 Brake	

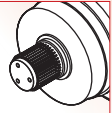
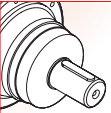
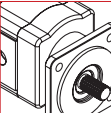
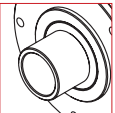
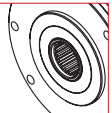
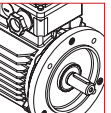
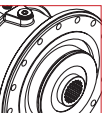
	<b>i</b>	<b>T<sub>2n</sub></b> (daNm)	<b>OUT</b>		<b>IN</b>	
<b>2502</b>	12.1 ÷ 21.3	126.4 ÷ 232.8	 Ø65	 58X53 DIN 5482	 Ø42 Ø65	 Hydraulic Motor
<b>2503</b>	39.4 ÷ 143.5	126.4 ÷ 256.5	 Ø75	 58X53 DIN 5482	 Electric Motor	
<b>2504</b>	140.1 ÷ 1244.1	126.4 ÷ 256.5			 Brake	



## DATI TECNICI

## TECHNICAL DATA



CHPL	i	T <sub>2n</sub> (n <sub>1</sub> =1400 rpm) [daNm]	P <sub>1n</sub> (n <sub>1</sub> =1400 rpm) [kW]	P <sub>t</sub> [kW]	IEC		CHM	CM / CP	
					(B5)				
2501	3.78	256.5	99	20	63 80 100 132 180	71 90 112 160	CHM 50 CHM 75	CHM 63 CHM 90	CM42 CM65 CP65
	4.13	232.8	83						
	5.17	193.8	55						
	6	162.5	40						
	7.25	126.4	26						
2502	13.4	256.5	28	12	63 80 100 132	71 90 112 160	CHM 50 CHM 75	CHM 63 CHM 90	CM42
	16.2	256.5	23						
	18.4	193.8	15						
	23.1	232.8	15						
	28.9	193.8	9.8						
	34.9	193.8	8.1						
	40.5	162.5	5.9						
	48.9	126.4	3.8						
62.8	126.4	2.9							
2503	52.1	232.8	6.5	8	63 80 100 132	71 90 112	CHM 50 CHM 75	CHM 63 CHM 90	CM42
	57.6	256.5	6.5						
	62.9	232.8	5.4						
	75.2	256.5	5.0						
	82.1	232.8	4.2						
	90.7	256.5	4.1						
	99	232.8	3.4						
	119.3	232.8	2.9						
	129.4	232.8	2.6						
	149.5	193.8	1.9						
	155.9	232.8	2.2						
	162	193.8	1.8						
	173.6	162.5	1.4						
	195.3	193.8	1.5						
	235.4	193.8	1.2						
	273.4	162.5	0.87						
302.2	193.8	0.94							
330.3	126.4	0.56							
424.1	126.4	0.44							
2504	352	232.8	0.97	4	63 80 100	71 90 112	CHM 50 CHM 75	CHM 63 CHM 90	CM42
	365.8	193.8	0.78						
	388.6	256.5	0.97						
	413.9	256.5	0.91						
	424.3	232.8	0.80						
	468.4	256.5	0.80						
	511.4	232.8	0.67						
	554.4	232.8	0.62						
	612	256.5	0.61						
	668.2	232.8	0.51						
	737.7	256.5	0.51						
	805.5	232.8	0.42						
	858	232.8	0.40						
	907.3	193.8	0.31						
	1052.5	232.8	0.32						
	1121.1	232.8	0.30						
1318.3	193.8	0.22							
1589	193.8	0.18							
1845.3	162.5	0.13							
2369.2	162.5	0.10							

n<sub>1max</sub> = 2800 rpm

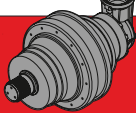

## DATI TECNICI

## TECHNICAL DATA

 CHPLB	i	T <sub>2n</sub> (n <sub>i</sub> =1400 rpm)	P <sub>1n</sub> (n <sub>i</sub> =1400 rpm)	P <sub>t</sub>	IEC	 CM / CP
		[daNm]	[kW]	[kW]	(B5)	
<b>2502</b>	12.1	232.8	28	12	63   71 80   90 100   112 132   160	CM42 CM65 CP65
	15.2	193.8	19			
	17.6	162.5	14			
	21.3	126.4	8.7			
<b>2503</b>	39.4	256.5	9.5	8	63   71 80   90 100   112 132   112	CM42 CM65 CP65
	47.5	256.5	7.9			
	53.9	193.8	5.3			
	67.8	232.8	5.0			
	75.4	162.5	3.2			
	84.9	193.8	3.3			
	91.1	126.4	2.0			
	102.3	193.8	2.8			
	118.8	162.5	2.0			
	143.5	126.4	1.3			
<b>2504</b>	140.1	256.5	2.7	4	63   71 80   90 100   112	CM42 CM65 CP65
	168.9	256.5	2.2			
	184.4	232.8	1.9			
	220.6	256.5	1.7			
	240.9	232.8	1.4			
	265.9	256.5	1.4			
	290.4	232.8	1.2			
	320.6	256.5	1.2			
	350	232.8	0.97			
	422.4	162.5	0.56			
	449.4	232.8	0.76			
	475.3	193.8	0.60			
	509.1	162.5	0.47			
	551.9	162.5	0.43			
	615.2	126.4	0.30			
	665.3	162.5	0.36			
735.5	193.8	0.39				
801.9	162.5	0.30				
1244.1	126.4	0.15				

n<sub>1max</sub> = 2800 rpm



## DIMENSIONI CMS

## CMS DIMENSIONS

**Accessori  
Accessories**

- CHYZ
- CHFL
- CHBS
- CHFF

p. D18

### CHPL 2500 CMS - Flange motori IEC

### CHPL 2500 CMS- IEC Motor flanges

CHPL	IEC 63			IEC 71			IEC 80			IEC 90			IEC 100		
	LP	P	ØD	LP	P	ØD	LP	P	ØD	LP	P	ØD	LP	P	ØD
2501	201			201			221			221			231		
2502	249	36	140	249	36	160	269	56	200	269	56	200	279	66	250
2503	297			297			317			317			327		
2504	345			345			365			365			375		

CHPL	IEC 112			IEC 132			IEC 160			IEC 180		
	LP	P	ØD	LP	P	ØD	LP	P	ØD	LP	P	ØD
2501	231			265			304			304	139	350
2502	279	66	250	313	100	300	352					-
2503	327			361								-
2504	375											-

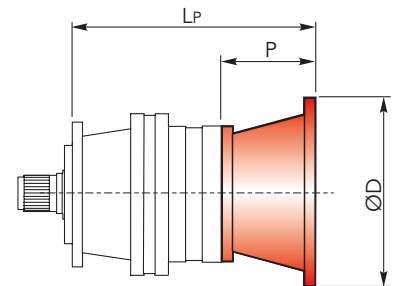

### CHPL 2500 CMS - Alberi maschi entrata

### CHPL 2500 CMS - Male input shafts

CHPL	CM42				CM65				CP65			
	LT	T	LE	ØE	LT	T	LE	ØE	LT	T	LE	ØE
2501	258				300	121.5	105	65 h6	331.5	153	105	65 h6
2502	306	93	82	42 h6								
2503	354											
2504	402											

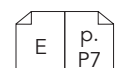
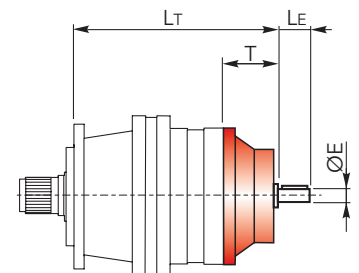



## DIMENSIONI CMS

## CMS DIMENSIONS

CHPL 2500 CMS - Riduttore a vite senza fine CHM in entrata CHPL 2500 CMS - CHM input worm gearboxes

CHPL	CHM 50					CHM 63				
	Lv	I	H	M	N	Lv	I	H	M	N
2501	290.5	50	110	60	80	300	63	135	72	95
2502	338.5					348				
2503	386.5					396				
2504	434.5					444				

CHPL	CHM 75					CHM 90				
	Lv	I	H	M	N	Lv	I	H	M	N
2501	279	75	161	86	112.5	289	90	193	103	129.5
2502	327					337				
2503	375					385				
2504	423					433				

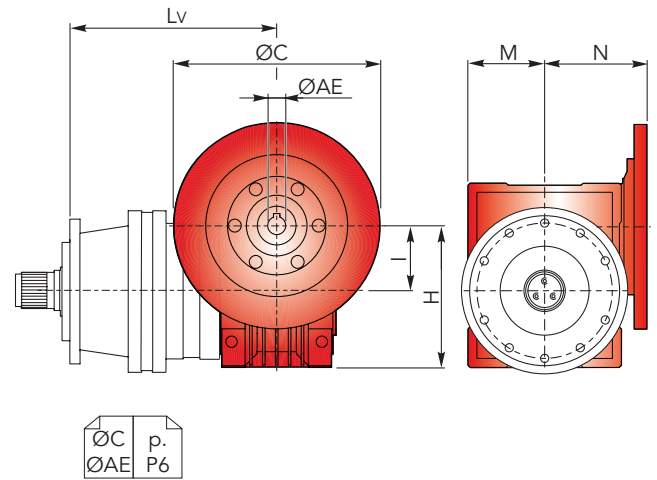

CHPL/CHPLB 2500

## CHPLB 2500 CMS - Flange motori IEC

## CHPLB 2500 CMS - IEC Motor flanges

CHPLB	IEC 63				IEC 71				IEC 80				IEC 90			
	L	LP	P	ØD	L	LP	P	ØD	L	LP	P	ØD	L	LP	P	ØD
2502	240				240				240				240			
2503	288	196	36	140	288	196	36	160	288	216	56	200	288	216	56	200
2504	336				336				336				336			

CHPLB	IEC 100				IEC 112				IEC 132				IEC 160			
	L	LP	P	ØD	L	LP	P	ØD	L	LP	P	ØD	L	LP	P	ØD
2502	240				240				240				240	299	139	350
2503	288	226	66	250	288	226	66	250	288	260	100	300	-			
2504	336				336				-				-			

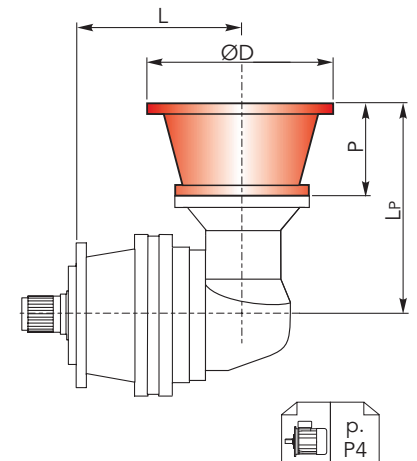

## CHPLB 2500 CMS - Alberi maschi entrata

## CHPL 2500 CMS - Male input shafts

CHPLB	CM42					CM65					CP65				
	L	L <sub>T</sub>	T	L <sub>E</sub>	ØE	L	L <sub>T</sub>	T	L <sub>E</sub>	ØE	L	L <sub>T</sub>	T	L <sub>E</sub>	ØE
2502	240					240					240				
2503	288	253	93	82	42 h6	288	297.5	121.5	105	65 h6	288	329	153	105	65 h6
2504	336					336					336				

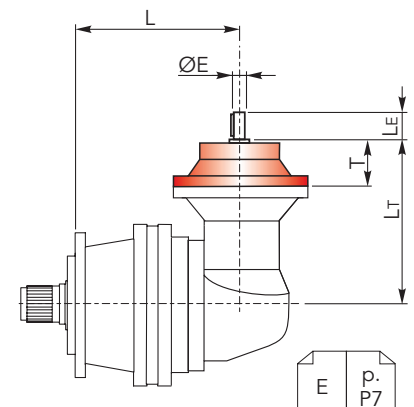



## DIMENSIONI CMC

## CMC DIMENSIONS

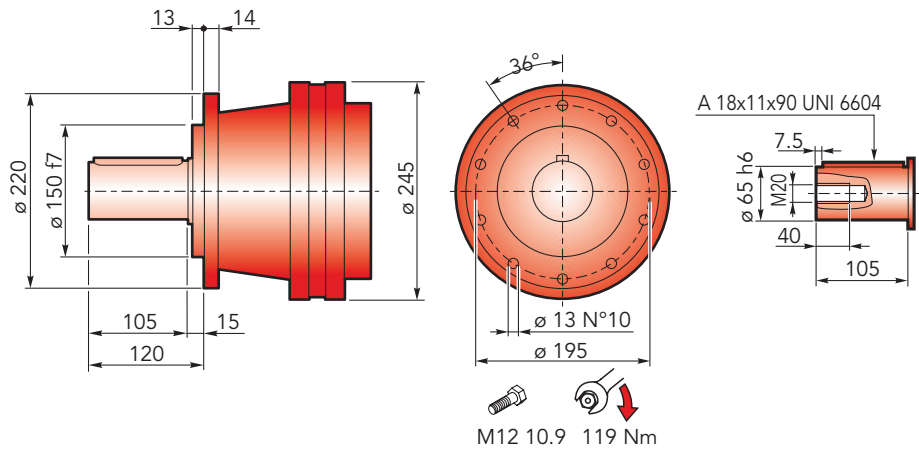

## CHPL 2500 CMC - Flange motori IEC

## CHPL 2500 CMC- IEC Motor flanges

CHPL	IEC 63			IEC 71			IEC 80			IEC 90			IEC 100		
	LP	P	ØD	LP	P	ØD	LP	P	ØD	LP	P	ØD	LP	P	ØD
2501	201			201			221			221			231		
2502	249	36	140	249	36	160	269	56	200	269	56	200	279	66	250
2503	297			297			317			317			327		
2504	345			345			365			365			375		

CHPL	IEC 112			IEC 132			IEC 160			IEC 180						
	LP	P	ØD	LP	P	ØD	LP	P	ØD	LP	P	ØD				
2501	231			265			304			304	139	350				
2502	279	66	250	313	100	300	352	139	350	-						
2503	327			361			-			-						
2504	375			-			-			-						

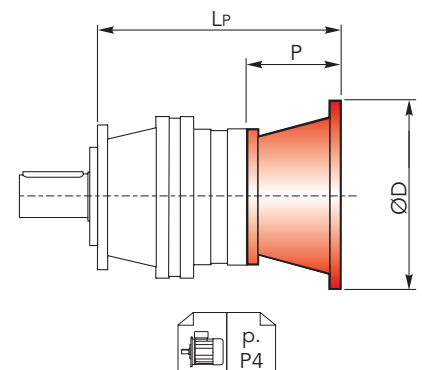

## CHPL 2500 CMC - Alberi maschi entrata

## CHPL 2500 CMC - Male input shafts

CHPL	CM42				CM65				CP65			
	LT	T	LE	ØE	LT	T	LE	ØE	LT	T	LE	ØE
2501	258				300	121.5	105	65 h6	331.5	153	105	65 h6
2502	306	93	82	42 h6	-				-			
2503	354				-				-			
2504	402				-				-			

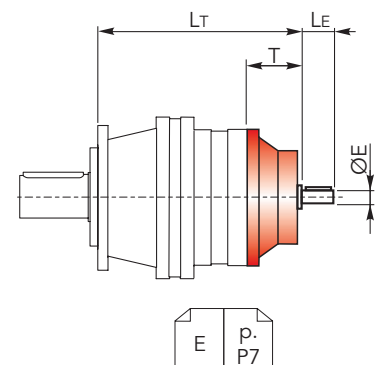





## DIMENSIONI CMC

## CMC DIMENSIONS

CHPL 2500 CMC - Riduttore a vite senza fine CHM in entrata CHPL 2500 CMC - CHM input worm gearboxes

CHPL	CHM 50					CHM 63				
	Lv	I	H	M	N	Lv	I	H	M	N
2501	290.5	50	110	60	80	300	63	135	72	95
2502	338.5					348				
2503	386.5					396				
2504	434.5					444				

CHPL	CHM 75					CHM 90				
	Lv	I	H	M	N	Lv	I	H	M	N
2501	279	75	161	86	112.5	289	90	193	103	129.5
2502	327					337				
2503	375					385				
2504	423					433				

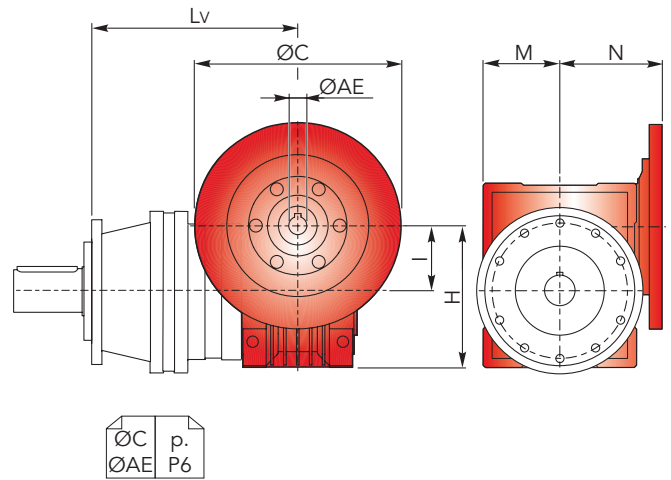

CHPL/CHPLB 2500

## CHPLB 2500 CMC - Flange motori IEC

## CHPLB 2500 CMC - IEC Motor flanges

CHPLB	IEC 63				IEC 71				IEC 80				IEC 90			
	L	LP	P	ØD	L	LP	P	ØD	L	LP	P	ØD	L	LP	P	ØD
2502	240				240				240				240			
2503	288	196	36	140	288	196	36	160	288	216	56	200	288	216	56	200
2504	336				336				336				336			

CHPLB	IEC 100				IEC 112				IEC 132				IEC 160			
	L	LP	P	ØD	L	LP	P	ØD	L	LP	P	ØD	L	LP	P	ØD
2502	240				240				240				240	299	139	350
2503	288	226	66	250	288	226	66	250	288	260	100	300	-			
2504	336				336				-				-			

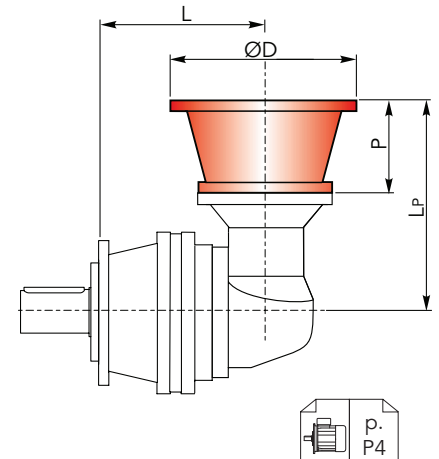

## CHPLB 2500 CMC - Alberi maschi entrata

## CHPL 2500 CMC - Male input shafts

CHPLB	CM42					CM65					CP65				
	L	LT	T	LE	ØE	L	LT	T	LE	ØE	L	LT	T	LE	ØE
2502	240					240					240				
2503	288	253	93	82	42 h6	288	297.5	121.5	105	65 h6	288	329	153	105	65 h6
2504	336					336					336				

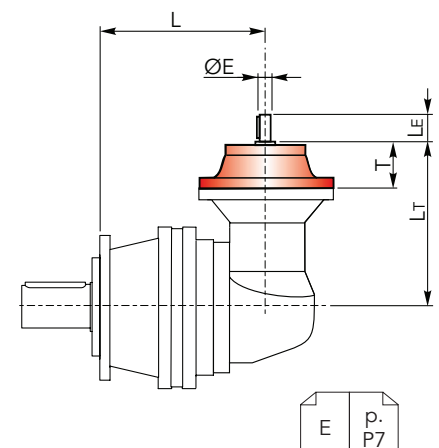



## DIMENSIONI CPS

## CPS DIMENSIONS

Technical drawing showing dimensions for the CHPL/CHPLB 2500 CPS motor. The main view shows a total length of 119.5 mm, with a mounting flange diameter of 272 mm and a main body diameter of 245 mm. The top view shows a 36° chamfered edge and a central hole of 13 mm diameter. A detail view shows the shaft with an M10 N° 3x120° thread and a 58x53 DIN 5482 nut. Dimensions for the detail include 25 mm, 60 f7, 50 f7, 32, 8, 50, 65, and 80 mm. Torque specification: M12 8.8 96.9 Nm.

**Accessori**  
Accessories

- CHYZ
- CHFL
- CHBS
- CHFF

p. D18

### CHPL 2500 CPS - Flange motori IEC

### CHPL 2500 CPS- IEC Motor flanges

CHPL	IEC 63			IEC 71			IEC 80			IEC 90			IEC 100		
	LP	P	ØD	LP	P	ØD	LP	P	ØD	LP	P	ØD	LP	P	ØD
2501	208			208			228			228			238		
2502	256	36	140	256	36	160	276	56	200	276	56	200	286	66	250
2503	304			304			324			324			334		
2504	352			352			372			372			382		

CHPL	IEC 112			IEC 132			IEC 160			IEC 180		
	LP	P	ØD	LP	P	ØD	LP	P	ØD	LP	P	ØD
2501	238			272			311			311	139	350
2502	286			320	100	300	359	139	350			-
2503	334	66	250	368								-
2504	382											-

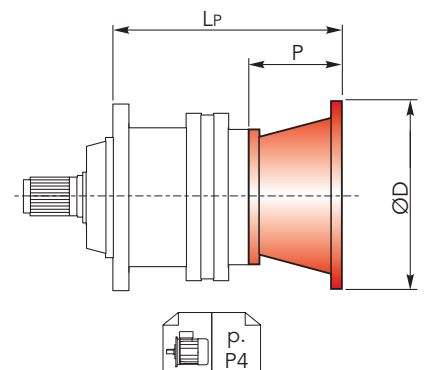

### CHPL 2500 CPS - Alberi maschi entrata

### CHPL 2500 CPS - Male input shafts

CHPL	CM42				CM65				CP65			
	LT	T	LE	ØE	LT	T	LE	ØE	LT	T	LE	ØE
2501	265				307	121.5	105	65 h6	338.5	153	105	65 h6
2502	313											
2503	361	93	82	42 h6								
2504	409											

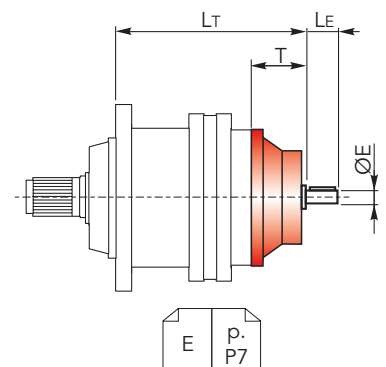



## DIMENSIONI CPS

## CPS DIMENSIONS

CHPL 2500 CPS - Riduttore a vite senza fine CHM in entrata

CHPL 2500 CPS - CHM input worm gearboxes

CHPL	CHM 50					CHM 63				
	Lv	I	H	M	N	Lv	I	H	M	N
2501	297.5	50	110	60	80	307	63	135	72	95
2502	345.5					355				
2503	393.5					403				
2504	441.5					451				

CHPL	CHM 75					CHM 90				
	Lv	I	H	M	N	Lv	I	H	M	N
2501	286	75	161	86	112.5	296	90	193	103	129.5
2502	334					344				
2503	382					392				
2504	430					440				

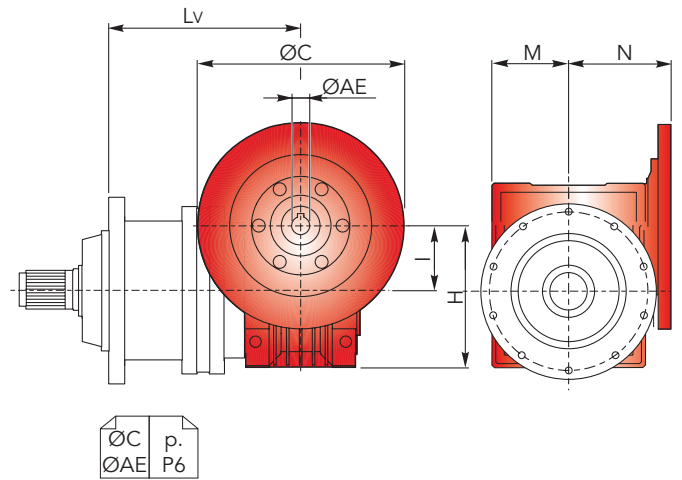

CHPL/CHPLB 2500

CHPLB 2500 CPS - Flange motori IEC

CHPLB 2500 CPS - IEC Motor flanges

CHPLB	IEC 63				IEC 71				IEC 80				IEC 90			
	L	LP	P	ØD	L	LP	P	ØD	L	LP	P	ØD	L	LP	P	ØD
2502	247				247				247				247			
2503	295	196	36	140	295	196	36	160	295	216	56	200	295	216	56	200
2504	343				343				343				343			

CHPLB	IEC 100				IEC 112				IEC 132				IEC 160			
	L	LP	P	ØD	L	LP	P	ØD	L	LP	P	ØD	L	LP	P	ØD
2502	247				247				247	260	100	300	247	299	139	350
2503	295	226	66	250	295	226	66	250	295				295			
2504	343				343				343				343			

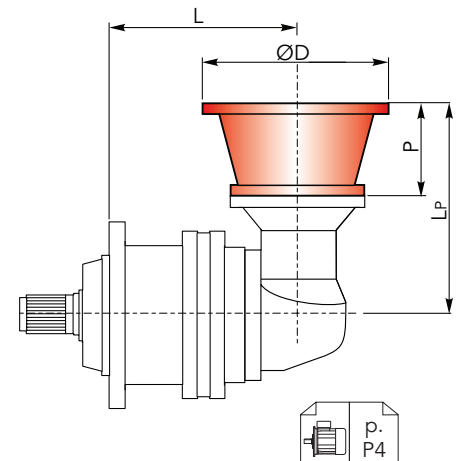

CHPLB 2500 CPS - Alberi maschi entrata

CHPL 2500 CPS - Male input shafts

CHPLB	CM42					CM65					CP65				
	L	LT	T	LE	ØE	L	LT	T	LE	ØE	L	LT	T	LE	ØE
2502	247					247					247				
2503	295	253	93	82	42 h6	295	297.5	121.5	105	65 h6	295	329	153	105	65 h6
2504	343					343					343				

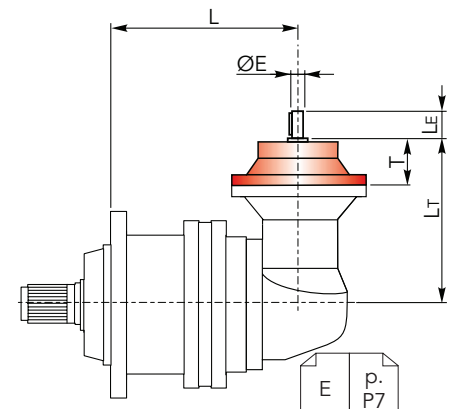



## DIMENSIONI CPC

## CPC DIMENSIONS

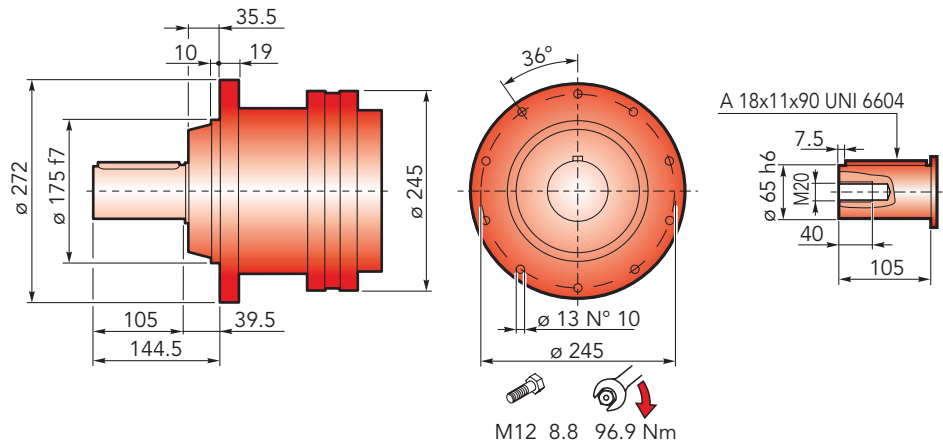

## CHPL 2500 CPC - Flange motori IEC

## CHPL 2500 CPC- IEC Motor flanges

CHPL	IEC 63			IEC 71			IEC 80			IEC 90			IEC 100		
	LP	P	ØD	LP	P	ØD	LP	P	ØD	LP	P	ØD	LP	P	ØD
2501	208			208			228			228			238		
2502	256	36	140	256	36	160	276	56	200	276	56	200	286	66	250
2503	304			304			324			324			334		
2504	352			352			372			372			382		

CHPL	IEC 112			IEC 132			IEC 160			IEC 180		
	LP	P	ØD	LP	P	ØD	LP	P	ØD	LP	P	ØD
2501	238			272			311			311	139	350
2502	286	66	250	320	100	300	359					-
2503	334			368								-
2504	382											-

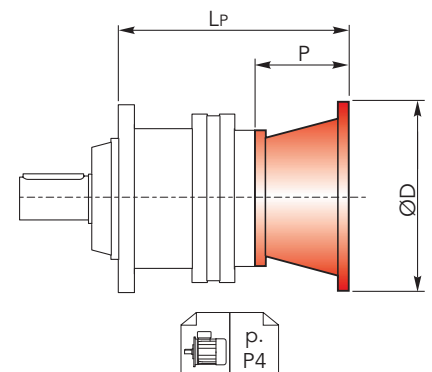

## CHPL 2500 CPC - Alberi maschi entrata

## CHPL 2500 CPC - Male input shafts

CHPL	CM42				CM65				CP65			
	LT	T	LE	ØE	LT	T	LE	ØE	LT	T	LE	ØE
2501	265				307	121.5	105	65 h6	338.5	153	105	65 h6
2502	313	93	82	42 h6								
2503	361											
2504	409											

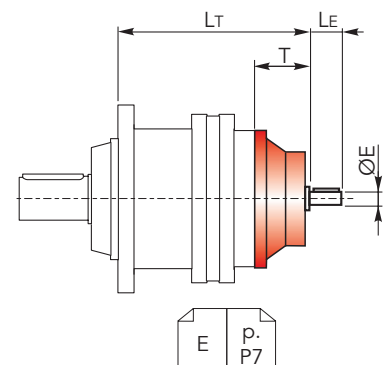



## DIMENSIONI CPC

## CPC DIMENSIONS

CHPL 2500 CPC - Riduttore a vite senza fine CHM in entrata

CHPL 2500 CPC - CHM input worm gearboxes

CHPL	CHM 50					CHM 63				
	Lv	I	H	M	N	Lv	I	H	M	N
2501	297.5	50	110	60	80	307	63	135	72	95
2502	345.5					355				
2503	393.5					403				
2504	441.5					451				

CHPL	CHM 75					CHM 90				
	Lv	I	H	M	N	Lv	I	H	M	N
2501	286	75	161	86	112.5	296	90	193	103	129.5
2502	334					344				
2503	382					392				
2504	430					440				

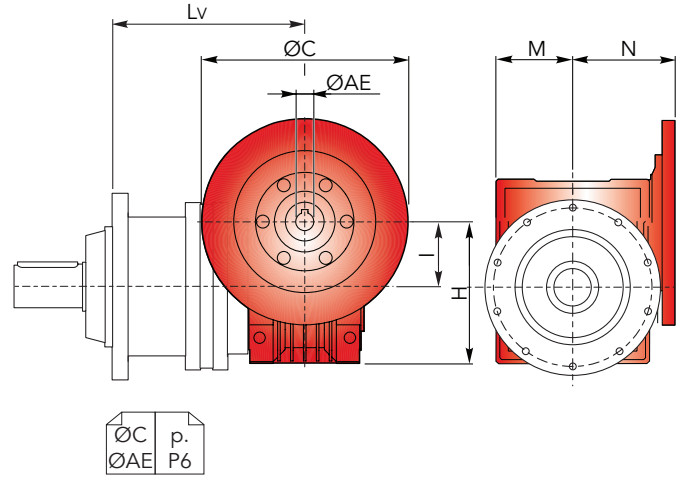

CHPL/CHPLB 2500

CHPLB 2500 CPC - Flange motori IEC

CHPLB 2500 CPC - IEC Motor flanges

CHPLB	IEC 63				IEC 71				IEC 80				IEC 90			
	L	LP	P	ØD	L	LP	P	ØD	L	LP	P	ØD	L	LP	P	ØD
2502	247				247				247				247			
2503	295	196	36	140	295	196	36	160	295	216	56	200	295	216	56	200
2504	343				343				343				343			

CHPLB	IEC 100				IEC 112				IEC 132				IEC 160			
	L	LP	P	ØD	L	LP	P	ØD	L	LP	P	ØD	L	LP	P	ØD
2502	247				247				247	260	100	300	247	299	139	350
2503	295	226	66	250	295	226	66	250	295				295			
2504	343				343				343				343			

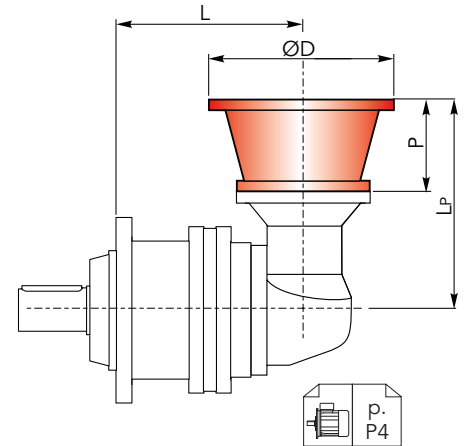

CHPLB 2500 CPC - Alberi maschi entrata

CHPL 2500 CPC - Male input shafts

CHPLB	CM42					CM65					CP65				
	L	LT	T	LE	ØE	L	LT	T	LE	ØE	L	LT	T	LE	ØE
2502	247					247					247				
2503	295	253	93	82	42 h6	295	297.5	121.5	105	65 h6	295	329	153	105	65 h6
2504	343					343					343				

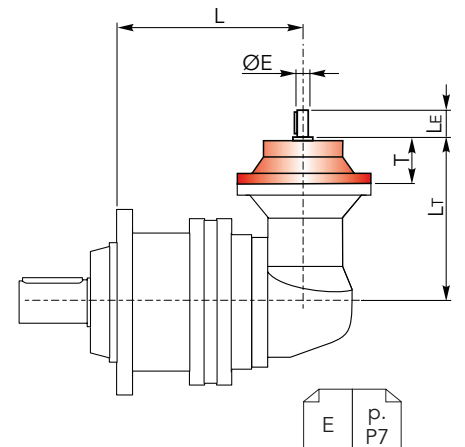



## DIMENSIONI CF

## CF DIMENSIONS

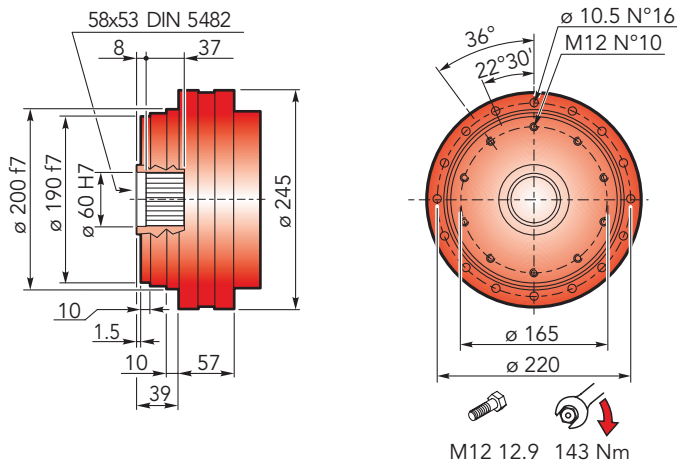

Accessori  
Accessories



### CHPL 2500 CF - Flange motori IEC

### CHPL 2500 CF- IEC Motor flanges

CHPL	IEC 63			IEC 71			IEC 80			IEC 90			IEC 100		
	L <sub>P</sub>	P	ØD	L <sub>P</sub>	P	ØD	L <sub>P</sub>	P	ØD	L <sub>P</sub>	P	ØD	L <sub>P</sub>	P	ØD
2501	114.5	36	140	114.5	36	160	134.5	56	200	134.5	56	200	144.5	66	250
2502	162.5			162.5			182.5			182.5			192.5		
2503	210.5			210.5			230.5			230.5			240.5		
2504	258.5			258.5			278.5			278.5			288.5		

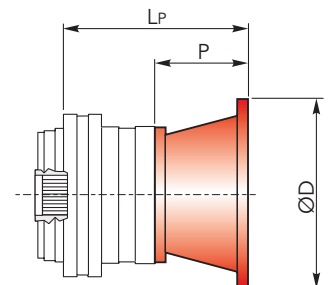

CHPL	IEC 112			IEC 132			IEC 160			IEC 180		
	L <sub>P</sub>	P	ØD	L <sub>P</sub>	P	ØD	L <sub>P</sub>	P	ØD	L <sub>P</sub>	P	ØD
2501	144.5	66	250	178.5	100	300	217.5	139	350	217.5	139	350
2502	192.5			226.5			265.5			-		
2503	240.5			274.5			-			-		
2504	288.5			-			-			-		

### CHPL 2500 CF - Alberi maschi entrata

### CHPL 2500 CF - Male input shafts

CHPL	CM42				CM65				CP65			
	L <sub>T</sub>	T	L <sub>E</sub>	ØE	L <sub>T</sub>	T	L <sub>E</sub>	ØE	L <sub>T</sub>	T	L <sub>E</sub>	ØE
2501	171.5	93	82	42 h6	213.5	121.5	105	65 h6	245	153	105	65 h6
2502	219.5				-	-	-					
2503	267.5				-	-	-					
2504	315.5				-	-	-					

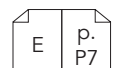
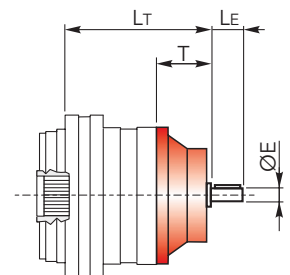



## DIMENSIONI CF

## CF DIMENSIONS

CHPL 2500 CF - Riduttore a vite senza fine CHM in entrata

CHPL 2500 CF - CHM input worm gearboxes

CHPL	CHM 50					CHM 63				
	Lv	I	H	M	N	Lv	I	H	M	N
2501	204	50	110	60	80	213.5	63	135	72	95
2502	252					261.5				
2503	300					309.5				
2504	348					357.5				

CHPL	CHM 75					CHM 90				
	Lv	I	H	M	N	Lv	I	H	M	N
2501	192.5	75	161	86	112.5	202.5	90	193	103	129.5
2502	240.5					250.5				
2503	288.5					298.5				
2504	336.5					346.5				

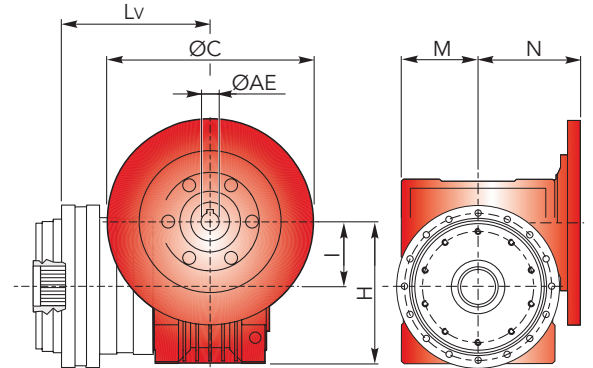

CHPL/CHPLB 2500

CHPLB 2500 CF - Flange motori IEC

CHPLB 2500 CF - IEC Motor flanges

CHPLB	IEC 63				IEC 71				IEC 80				IEC 90			
	L	LP	P	ØD	L	LP	P	ØD	L	LP	P	ØD	L	LP	P	ØD
2502	191	196	36	140	191	196	36	160	191	216	56	200	191	216	56	200
2503	239				239				239							
2504	287				287				287							

CHPLB	IEC 100				IEC 112				IEC 132				IEC 160			
	L	LP	P	ØD	L	LP	P	ØD	L	LP	P	ØD	L	LP	P	ØD
2502	191	226	66	250	191	226	66	250	191	260	100	300	191	299	139	350
2503	239				239				239				-			
2504	287				287				287				-			

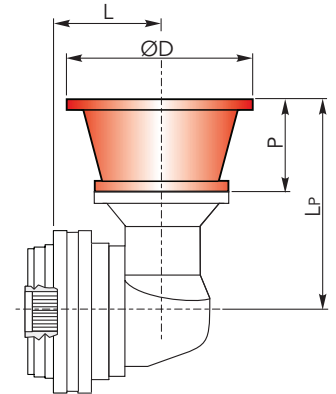

CHPLB 2500 CF - Alberi maschi entrata

CHPL 2500 CF - Male input shafts

CHPLB	CM42					CM65					CP65				
	L	LT	T	LE	ØE	L	LT	T	LE	ØE	L	LT	T	LE	ØE
2502	191	253	93	82	42 h6	191	297.5	121.5	105	65 h6	191	329	153	105	65 h6
2503	239					239					239				
2504	287					287					287				

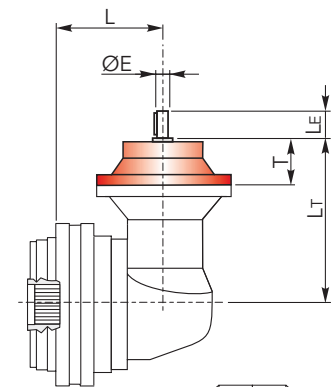



## DIMENSIONI CFS

## CFS DIMENSIONS

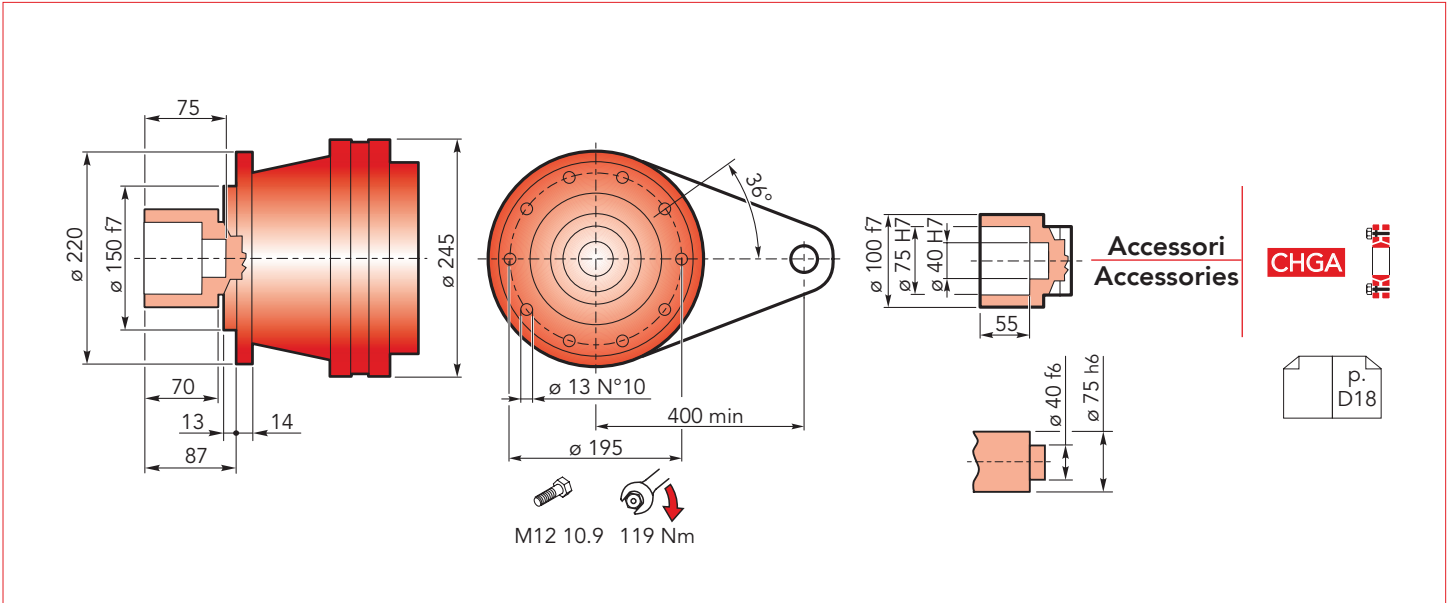

### CHPL 2500 CFS - Flange motori IEC

### CHPL 2500 CFS- IEC Motor flanges

CHPL	IEC 63			IEC 71			IEC 80			IEC 90			IEC 100		
	LP	P	ØD	LP	P	ØD	LP	P	ØD	LP	P	ØD	LP	P	ØD
2501	201	36	140	201	36	160	221	56	200	221	56	200	231	66	250
2502	249			249			269			269			279		
2503	297			297			317			317			327		
2504	345			345			365			365			375		

CHPL	IEC 112			IEC 132			IEC 160			IEC 180		
	LP	P	ØD	LP	P	ØD	LP	P	ØD	LP	P	ØD
2501	231	66	250	265	100	300	304	139	350	304	139	350
2502	279			313			352			-		
2503	327			361			-			-		
2504	375			-			-			-		

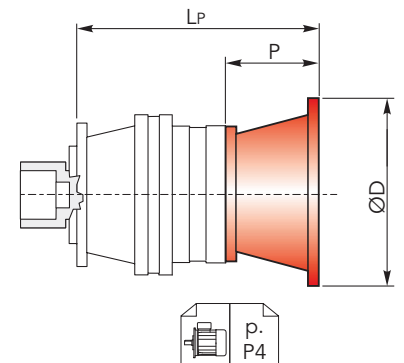

### CHPL 2500 CFS - Alberi maschi entrata

### CHPL 2500 CFS - Male input shafts

CHPL	CM42				CM65				CP65			
	LT	T	LE	ØE	LT	T	LE	ØE	LT	T	LE	ØE
2501	258	93	82	42 h6	300	121.5	105	65 h6	331.5	153	105	65 h6
2502	306				-	-	-					
2503	354				-	-	-					
2504	402				-	-	-					

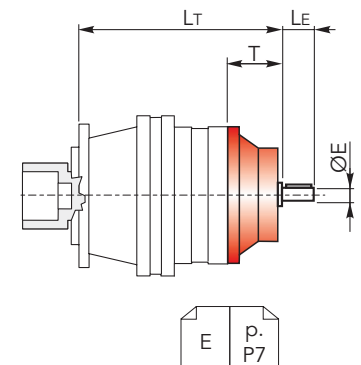





## DIMENSIONI CFS

## CFS DIMENSIONS

CHPL 2500 CFS - Riduttore a vite senza fine CHM in entrata

CHPL 2500 CFS - CHM input worm gearboxes

CHPL	CHM 50					CHM 63				
	Lv	I	H	M	N	Lv	I	H	M	N
2501	290.5	50	110	60	80	300	63	135	72	95
2502	338.5					348				
2503	386.5					396				
2504	434.5					444				

CHPL	CHM 75					CHM 90				
	Lv	I	H	M	N	Lv	I	H	M	N
2501	279	75	161	86	112.5	289	90	193	103	129.5
2502	327					337				
2503	375					385				
2504	423					433				

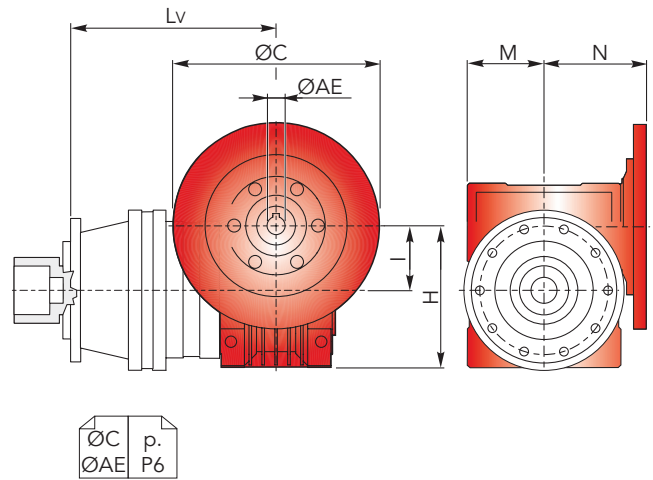

CHPL/CHPLB 2500

CHPLB 2500 CFS - Flange motori IEC

CHPLB 2500 CFS - IEC Motor flanges

CHPLB	IEC 63				IEC 71				IEC 80				IEC 90			
	L	LP	P	ØD	L	LP	P	ØD	L	LP	P	ØD	L	LP	P	ØD
2502	240				240				240				240			
2503	288	196	36	140	288	196	36	160	288	216	56	200	288	216	56	200
2504	336				336				336				336			

CHPLB	IEC 100				IEC 112				IEC 132				IEC 160			
	L	LP	P	ØD	L	LP	P	ØD	L	LP	P	ØD	L	LP	P	ØD
2502	240				240				240				240	299	139	350
2503	288	226	66	250	288	226	66	250	288	260	100	300	-			
2504	336				336				-				-			

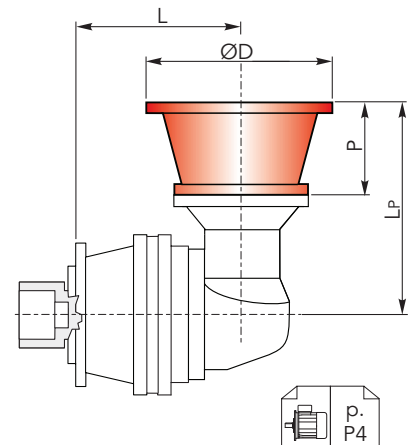

CHPLB 2500 CFS - Alberi maschi entrata

CHPL 2500 CFS - Male input shafts

CHPLB	CM42					CM65					CP65				
	L	L <sub>T</sub>	T	L <sub>E</sub>	ØE	L	L <sub>T</sub>	T	L <sub>E</sub>	ØE	L	L <sub>T</sub>	T	L <sub>E</sub>	ØE
2502	240					240					240				
2503	288	253	93	82	42 h6	288	297.5	121.5	105	65 h6	288	329	153	105	65 h6
2504	336					336					336				

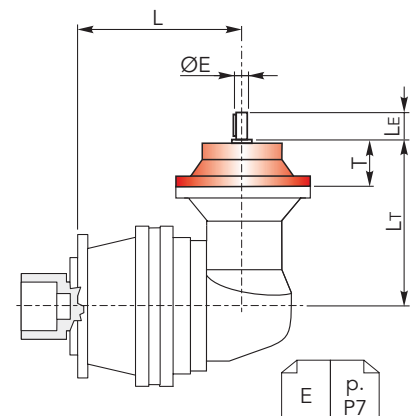



**DIMENSIONI CCPC**

**CCPC DIMENSIONS**

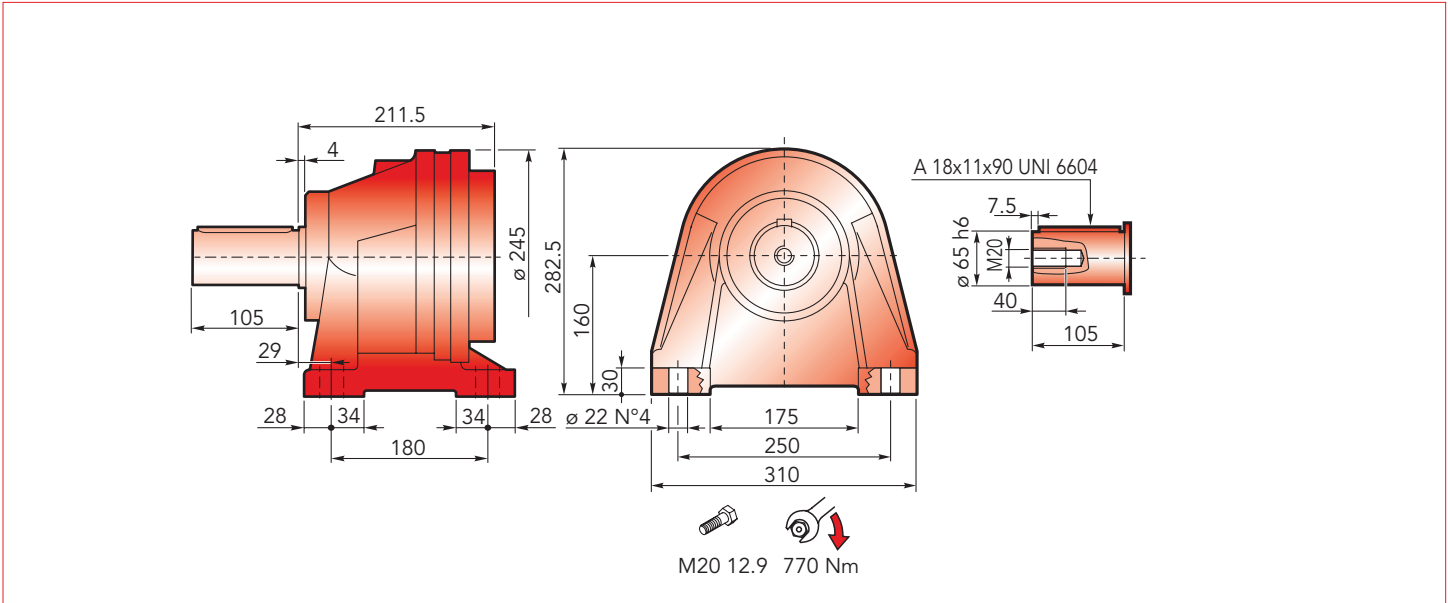

**CHPL 2500 CCPC - Flange motori IEC**

**CHPL 2500 CCPC- IEC Motor flanges**

CHPL	IEC 63			IEC 71			IEC 80			IEC 90			IEC 100		
	LP	P	ØD	LP	P	ØD	LP	P	ØD	LP	P	ØD	LP	P	ØD
2501	247.5	36	140	247.5	36	160	267.5	56	200	267.5	56	200	277.5	66	250
2502	295.5			295.5			315.5			315.5			325.5		
2503	343.5			343.5			363.5			363.5			373.5		
2504	391.5			391.5			411.5			411.5			421.5		

CHPL	IEC 112			IEC 132			IEC 160			IEC 180		
	LP	P	ØD	LP	P	ØD	LP	P	ØD	LP	P	ØD
2501	277.5	66	250	311.5	100	300	350.5	139	350	350.5	139	350
2502	325.5			359.5			398.5			-		
2503	373.5			407.5			-			-		
2504	421.5			-			-			-		

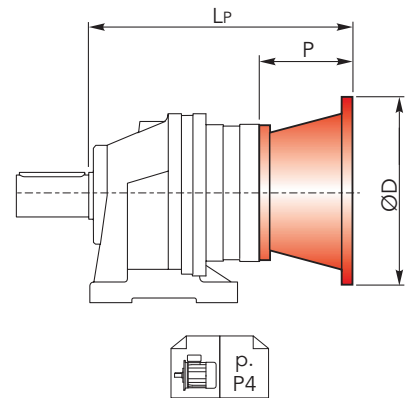

**CHPL 2500 CCPC - Alberi maschi entrata**

**CHPL 2500 CCPC - Male input shafts**

CHPL	CM42				CM65				CP65			
	LT	T	LE	ØE	LT	T	LE	ØE	LT	T	LE	ØE
2501	304.5	93	82	42 h6	346.5	121.5	105	65 h6	378	153	105	65 h6
2502	352.5				-	-	-					
2503	400.5				-	-	-					
2504	448.5				-	-	-					

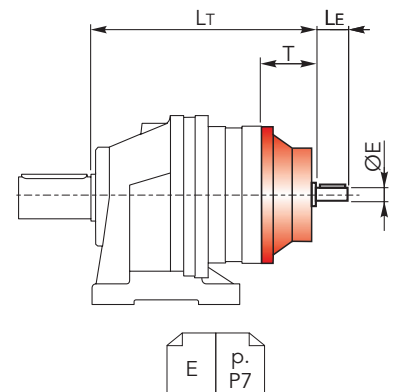



## DIMENSIONI CCPC

## CCPC DIMENSIONS

CHPL 2500 CCPC - Riduttore a vite senza fine CHM in entrata CHPL 2500 CCPC - CHM input worm gearboxes

CHPL	CHM 50					CHM 63				
	Lv	I	H	M	N	Lv	I	H	M	N
2501	337	50	110	60	80	346.5	63	135	72	95
2502	385					394.5				
2503	433					442.5				
2504	481					490.5				

CHPL	CHM 75					CHM 90				
	Lv	I	H	M	N	Lv	I	H	M	N
2501	325.5	75	161	86	112.5	335.5	90	193	103	129.5
2502	373.5					383.5				
2503	421.5					431.5				
2504	469.5					479.5				

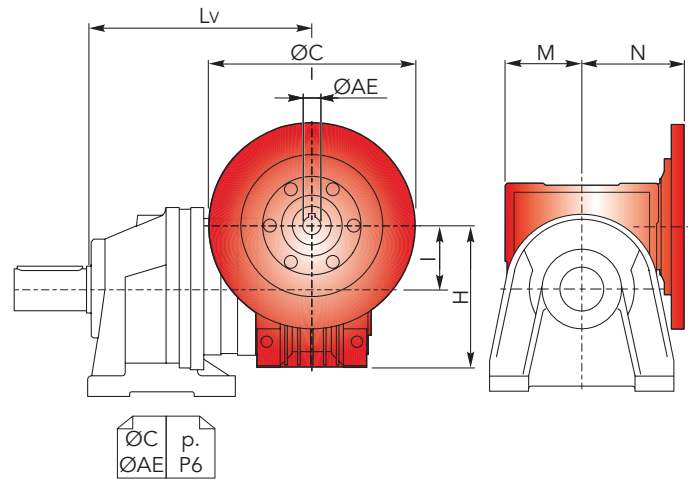

CHPL/CHPLB 2500

## CHPLB 2500 CCPC - Flange motori IEC

## CHPLB 2500 CCPC - IEC Motor flanges

CHPLB	IEC 63				IEC 71				IEC 80				IEC 90			
	L	Lp	P	ØD	L	Lp	P	ØD	L	Lp	P	ØD	L	Lp	P	ØD
2502	286.5	196	36	140	286.5	196	36	160	286.5	216	56	200	286.5	216	56	200
2503	334.5				334.5				334.5							
2504	382.5				382.5				382.5							

CHPLB	IEC 100				IEC 112				IEC 132				IEC 160			
	L	Lp	P	ØD	L	Lp	P	ØD	L	Lp	P	ØD	L	Lp	P	ØD
2502	286.5	226	66	250	286.5	226	66	250	286.5	260	100	300	286.5	299	139	350
2503	334.5				334.5				-							
2504	382.5				382.5				-							

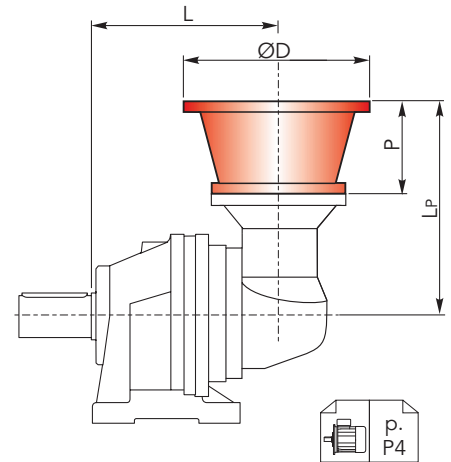

## CHPLB 2500 CCPC - Alberi maschi entrata

## CHPL 2500 CCPC - Male input shafts

CHPLB	CM42					CM65					CP65				
	L	Lt	T	Le	ØE	L	Lt	T	Le	ØE	L	Lt	T	Le	ØE
2502	286.5	253	93	82	42 h6	286.5	297.5	121.5	105	65 h6	286.5	329	153	105	65 h6
2503	334.5					334.5					334.5				
2504	382.5					382.5					382.5				

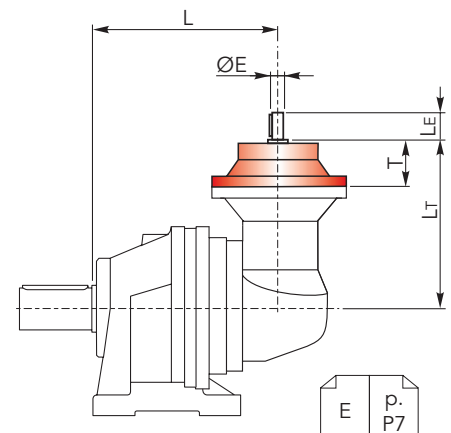



## ACCESSORI

## ACCESSORIES

CHYZ



Pignoni / Pinions

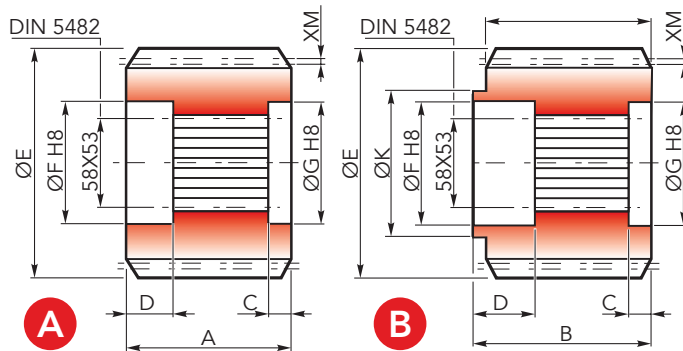

	Uscita / Output											Codice / Code	
		M	Z	XM	A	B	C	D	E	F	G		K
A	CMS	8	13	0	68	-	8.5	22.5	120	60	60	-	1071.218.042
	CMS	8	11	5	68	-	8.5	22.5	110.8	60	60	-	1071.258.042
	CMS	8	12	0	68	-	8	21	112.8	60	60	-	1071.196.042
	CMS	8	15	0	686	-	8.5	22.5	136	60	60	-	1071.163.042
	CPS	6	14	3	95	.	23	21	99.6	60	60	-	1071.160.042
	CPS	10	11	8	90	-	8.5	22.5	142.1	60	60	-	1071.297.042
B	CPS	10	14	3.2	103	116	9.5	22.5	162.4	60	60	105	1071.298.042

CHFF

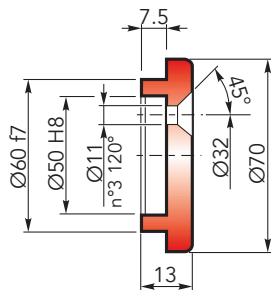

Fondello di arresto / Stop bottom plate

Codice / Code:  
1075.015.000

CHBS

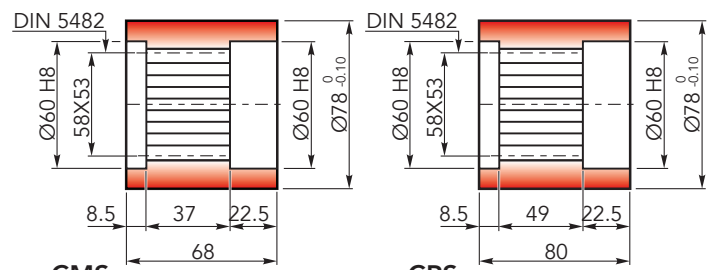

Boccola scanalata / Splined bushing

CMS  
Codice / Code:  
2171.101.076CPS  
Codice / Code:  
4171.101.076

CHKB

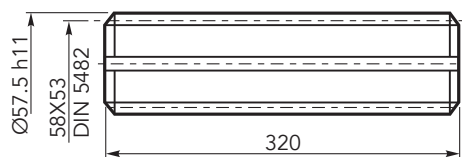

Barra scanalata / Splined rod

Codice / Code:  
3071.181.042

CHGA

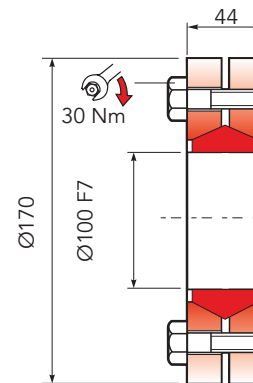

Giunto di attrito / Shrink disc

Coppia max: 7500 Nm (1)  
Max Torque: 7500 Nm (1)Codice / Code:  
5109.100.000

(1): Coppia max indicata è valida solo con calettatori forniti da Chiaravalli S.p.A.

(1): The maximum torque indicated is valid only with shrink discs supplied by Chiaravalli S.p.A.

CHFL



Flangia / Flange

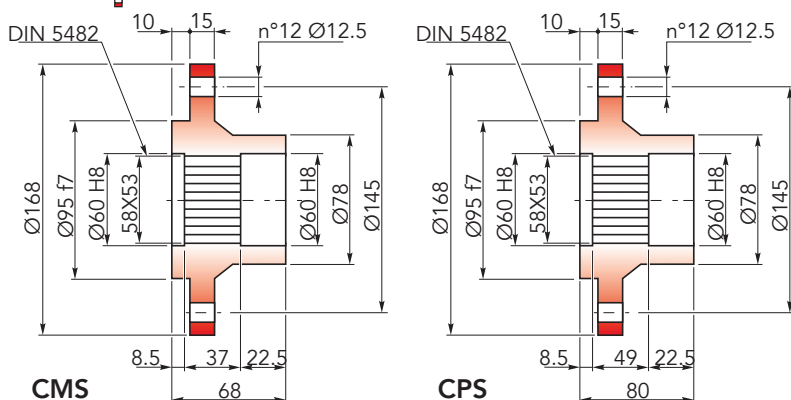

CMS

Codice / Code:  
2171.103.025

CPS

Codice / Code:  
4171.103.098



## CARICHI RADIALI (Fr)

Nel diagramma seguente, sono indicati i carichi radiali Fr (N) applicabili sull'albero uscita in funzione della distanza di applicazione L rispetto alla battuta dell'albero.

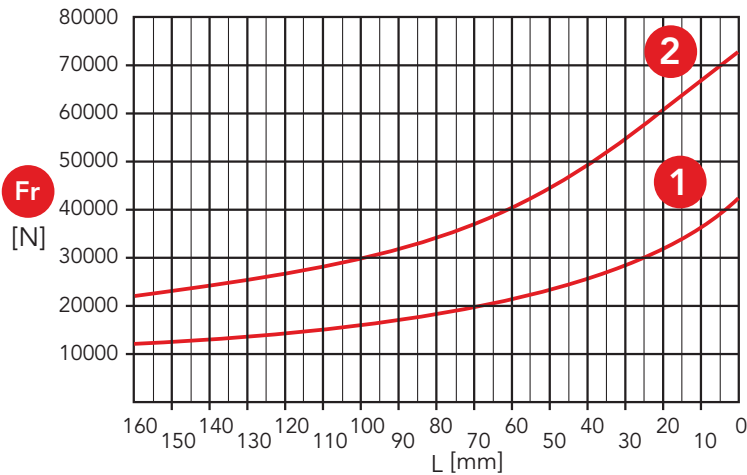

The hereunder table shows the allowable radial loads Fr (N) on the output shaft with reference to the distance L.

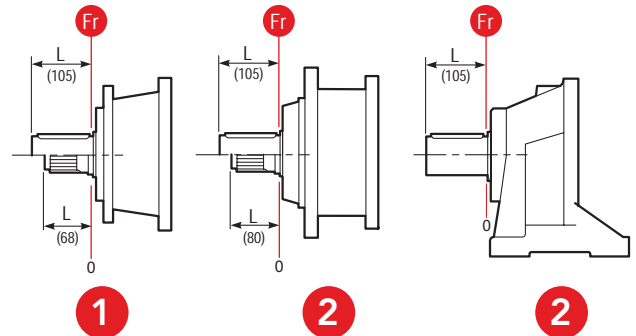

- 1 Uscita / Output: CMS, CMC
- 2 Uscita / Output: CPS, CPC, CCPC

## CARICHI ASSIALI (Fa)

Nella tabella seguente sono indicati i carichi assiali Fa (N) applicabili sull'albero di uscita in funzione della direzione di applicazione del carico e della versione.

	1	2	
Fa [N]	32000	32000	←
	32000	48000	→

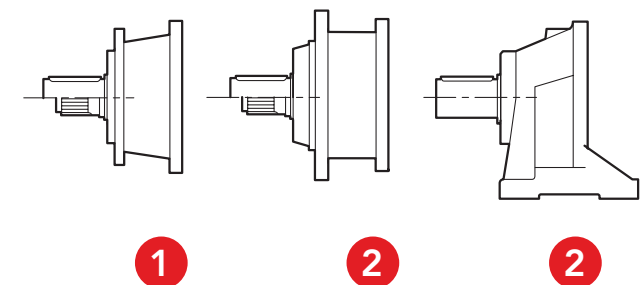





- 1 Uscita / Output: CMS, CMC
- 2 Uscita / Output: CPS, CPC, CCPC



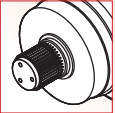
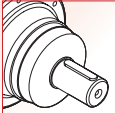
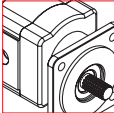
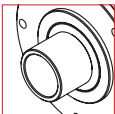
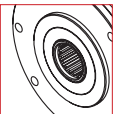
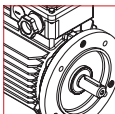
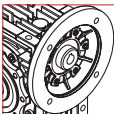

# CHPL/CHPLB 5000

	<b>i</b>	<b>T<sub>2n</sub></b> (daNm)	<b>OUT</b>		<b>IN</b>	
<b>5001</b>	3.78 ÷ 7.25	191.0 ÷ 373.4	 Ø65	 58X53 DIN 5482	 Ø42 Ø65	 Hydraulic Motor
<b>5002</b>	13.4 ÷ 48.9	191.0 ÷ 373.4	 Ø75	 58X53 DIN 5482	 Electric Motor	 Worm gearboxes
<b>5003</b>	52.1 ÷ 330.3	191.0 ÷ 373.4				
<b>5004</b>	352.0 ÷ 1845.3	244.2 ÷ 373.4			 Brake	

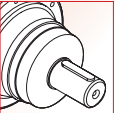
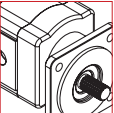
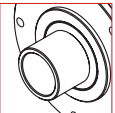
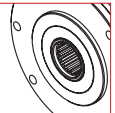
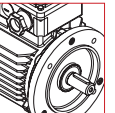
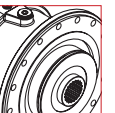
	<b>i</b>	<b>T<sub>2n</sub></b> (daNm)	<b>OUT</b>		<b>IN</b>	
<b>5002</b>	13.1 ÷ 39.5	191.0 ÷ 373.4	 Ø65	 58X53 DIN 5482	 Ø42 Ø65	 Hydraulic Motor
<b>5003</b>	39.4 ÷ 143.5	191.0 ÷ 373.4	 Ø75	 58X53 DIN 5482	 Electric Motor	
<b>5004</b>	140.1 ÷ 1244.1	191.0 ÷ 373.4			 Brake	



## DATI TECNICI

## TECHNICAL DATA

CHPL	i	T <sub>2n</sub> (n <sub>1</sub> =1400 rpm) [daNm]	P <sub>1n</sub> (n <sub>1</sub> =1400 rpm) [kW]	P <sub>t</sub> [kW]	IEC		CHM	CM / CP	
					(B5)				
5001	3.78	373.4	145	20	63 80 100 132 180	71 90 112 160	CHM 50 CHM 75	CHM 63 CHM 90	CM42 CM65 CP65
	4.13	340.1	121						
	5.17	278.4	79						
	6	244.2	60						
	7.25	191.0	39						
5002	13.4	373.4	41	15	63 80 100 132	71 90 112 160	CHM 50 CHM 75	CHM 63 CHM 90	CM42
	16.2	373.4	34						
	18.4	278.4	22						
	23.1	340.1	22						
	28.9	278.4	14						
	34.9	278.4	12						
	40.5	244.2	8.8						
	48.9	191.0	5.7						
5003	52.1	340.1	9.6	10	63 80 100 132	71 90 112 160	CHM 50 CHM 75	CHM 63 CHM 90	CM42
	57.6	373.4	9.5						
	62.9	340.1	7.9						
	75.2	373.4	7.3						
	82.1	340.1	6.1						
	90.7	373.4	6.0						
	99	340.1	5.0						
	119.3	340.1	4.2						
	129.4	340.1	3.9						
	149.5	278.4	2.7						
	155.9	340.1	3.2						
	162	278.4	2.5						
	173.6	244.2	2.1						
	195.3	278.4	2.1						
	235.4	278.4	1.7						
	273.4	244.2	1.3						
302.2	278.4	1.4							
330.3	191.0	0.85							
5004	352	340.1	1.4	6	63 80 100 132	71 90 112	CHM 50 CHM 75	CHM 63 CHM 90	CM42
	365.8	278.4	1.1						
	388.6	373.4	1.4						
	413.9	373.4	1.3						
	424.3	340.1	1.2						
	468.4	373.4	1.2						
	511.4	340.1	0.97						
	554.4	340.1	0.90						
	612	373.4	0.89						
	668.2	340.1	0.75						
	737.7	373.4	0.74						
	805.5	340.1	0.62						
	858	340.1	0.58						
	907.3	278.4	0.45						
	1052.5	340.1	0.47						
	1121.1	340.1	0.44						
1318.3	278.4	0.31							
1589	278.4	0.26							
1845.3	244.2	0.19							



n<sub>1max</sub> = 2800 rpm



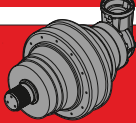

## DATI TECNICI

## TECHNICAL DATA

 CHPLB	i	T <sub>2n</sub> (n <sub>1</sub> =1400 rpm)	P <sub>1n</sub> (n <sub>1</sub> =1400 rpm)	P <sub>t</sub>	IEC	 CM / CP
		[daNm]	[kW]	[kW]	(B5)	
<b>5002</b>	13.1	373.4	42	15	63   71 80   90 100   112 132   160	CM42 CM65 CP65
	14.2	340.1	35			
	17.8	278.4	23			
	20.6	373.4	26.6			
	22.5	340.1	22.2			
	28.1	278.4	14.5			
	32.7	244.2	10.9			
	39.5	191.0	7.1			
<b>5003</b>	39.4	373.4	13.9	10	63   71 80   90 100   112 132	CM42 CM65 CP65
	47.5	373.4	11.5			
	53.9	278.4	7.6			
	67.8	340.1	7.4			
	75.4	244.2	4.7			
	84.9	278.4	4.8			
	91.1	191.0	3.1			
	102.3	278.4	4.0			
	118.8	244.2	3.0			
	143.5	191.0	2.0			
<b>5004</b>	140.1	373.4	3.9	6	63   71 80   90 100   112 132	CM42 CM65 CP65
	168.9	373.4	3.2			
	184.4	340.1	2.7			
	220.6	373.4	2.5			
	240.9	340.1	2.07			
	265.9	373.4	2.06			
	290.4	340.1	1.72			
	320.6	373.4	1.71			
	350	340.1	1.42			
	422.4	244.2	0.85			
	449.4	340.1	1.11			
	475.3	278.4	0.86			
	509.1	244.2	0.70			
	551.9	244.2	0.65			
	615.2	191.0	0.46			
	665.3	244.2	0.54			
	735.5	278.4	0.56			
	801.9	244.2	0.45			
1244.1	191.0	0.23				

n<sub>1max</sub> = 2800 rpm



## DIMENSIONI CMS

## CMS DIMENSIONS

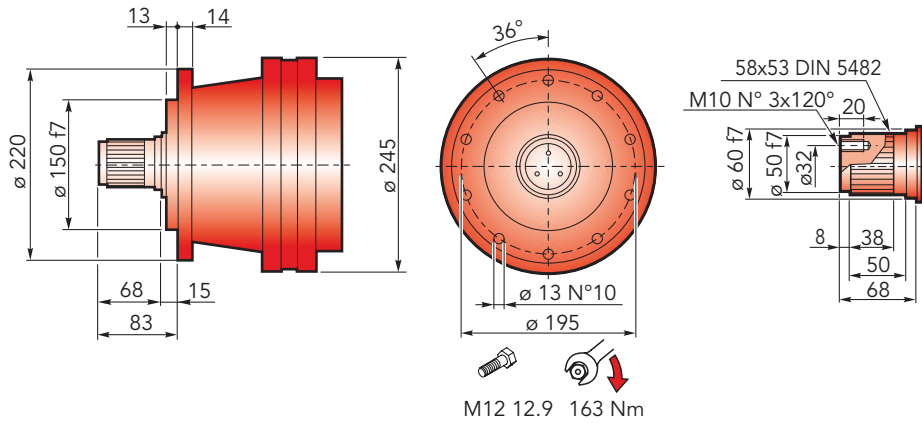
Accessori  
Accessories

## CHPL 5000 CMS - Flange motori IEC

## CHPL 5000 CMS- IEC Motor flanges

CHPL	IEC 63			IEC 71			IEC 80			IEC 90			IEC 100		
	Lp	P	ØD	Lp	P	ØD	Lp	P	ØD	Lp	P	ØD	Lp	P	ØD
5001	213			213			233			233			243		
5002	274	36	140	274	36	160	294	56	200	294	56	200	304	66	250
5003	322			322			342			342			352		
5004	370			370			390			390			400		

CHPL	IEC 112			IEC 132			IEC 160			IEC 180		
	Lp	P	ØD	Lp	P	ØD	Lp	P	ØD	Lp	P	ØD
5001	243			277			316			316	139	350
5002	304	66	250	338	100	300	377	139	350	-	-	-
5003	352			386			425			-	-	-
5004	400			434			-			-	-	-

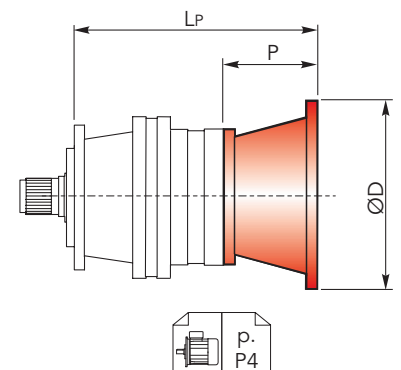

## CHPL 5000 CMS - Alberi maschi entrata

## CHPL 5000 CMS - Male input shafts

CHPL	CM42				CM65				CP65			
	Lt	T	Le	ØE	Lt	T	Le	ØE	Lt	T	Le	ØE
5001	270				312	121.5	105	65 h6	343.5	153	105	65 h6
5002	331	93	82	42 h6	-	-	-	-	-	-	-	-
5003	379				-	-	-	-	-	-	-	-
5004	427				-	-	-	-	-	-	-	-

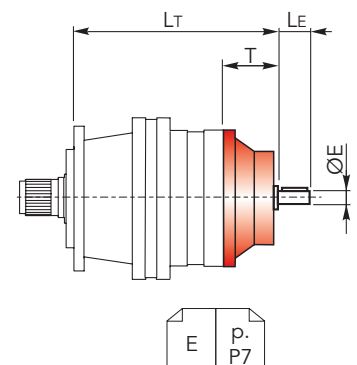



## DIMENSIONI CMS

## CMS DIMENSIONS

CHPL 5000 CMS - Riduttore a vite senza fine CHM in entrata CHPL 5000 CMS - CHM input worm gearboxes

CHPL	CHM 50					CHM 63				
	Lv	I	H	M	N	Lv	I	H	M	N
5001	302.5	50	110	60	80	312	63	135	72	95
5002	363.5					373				
5003	411.5					421				
5004	459.5					469				

CHPL	CHM 75					CHM 90				
	Lv	I	H	M	N	Lv	I	H	M	N
5001	291	75	161	86	112.5	301	90	193	103	129.5
5002	352					362				
5003	400					410				
5004	448					458				

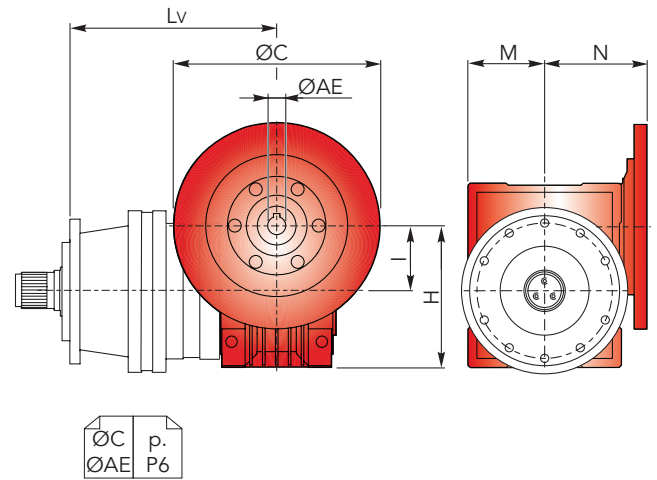

CHPL/CHPLB 5000

## CHPLB 5000 CMS - Flange motori IEC

## CHPLB 5000 CMS - IEC Motor flanges

CHPLB	IEC 63				IEC 71				IEC 80				IEC 90			
	L	LP	P	ØD	L	LP	P	ØD	L	LP	P	ØD	L	LP	P	ØD
5002	278.5	276	36	140	278.5	276	36	160	278.5	296	56	200	278.5	296	56	200
5003	313	196			313	196			313	216			313	216		
5004	361	361			361	361			361	361			361	361		

CHPLB	IEC 100				IEC 112				IEC 132				IEC 160			
	L	LP	P	ØD	L	LP	P	ØD	L	LP	P	ØD	L	LP	P	ØD
5002	278.5	306	66	250	278.5	306	66	250	278.5	340	100	300	278.5	379	139	350
5003	313	226			313	226			313	260			-			
5004	361	361			361	361			361	361			-			

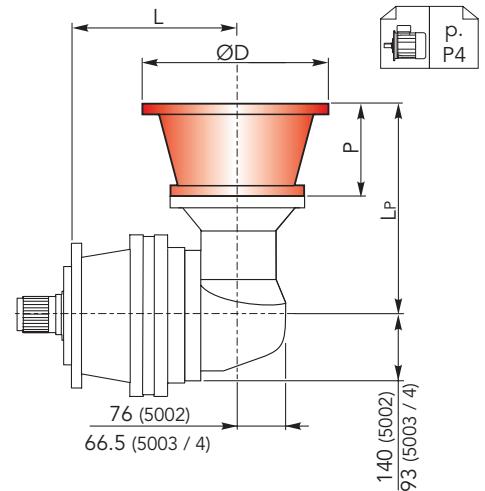

## CHPLB 5000 CMS - Alberi maschi entrata

## CHPL 5000 CMS - Male input shafts

CHPLB	CM42					CM65					CP65				
	L	L <sub>T</sub>	T	L <sub>E</sub>	ØE	L	L <sub>T</sub>	T	L <sub>E</sub>	ØE	L	L <sub>T</sub>	T	L <sub>E</sub>	ØE
5002	278.5	333	93	82	42 h6	278.5	377.5	121.5	105	65 h6	278.5	409	153	105	65 h6
5003	313	253				313	297.5				313	329			
5004	361	361				361	361				361	361			

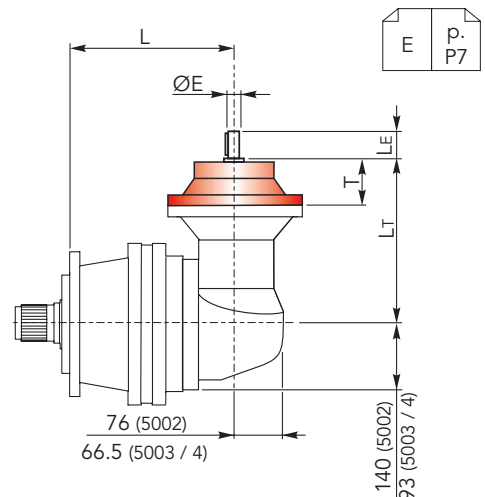



## DIMENSIONI CMC

## CMC DIMENSIONS

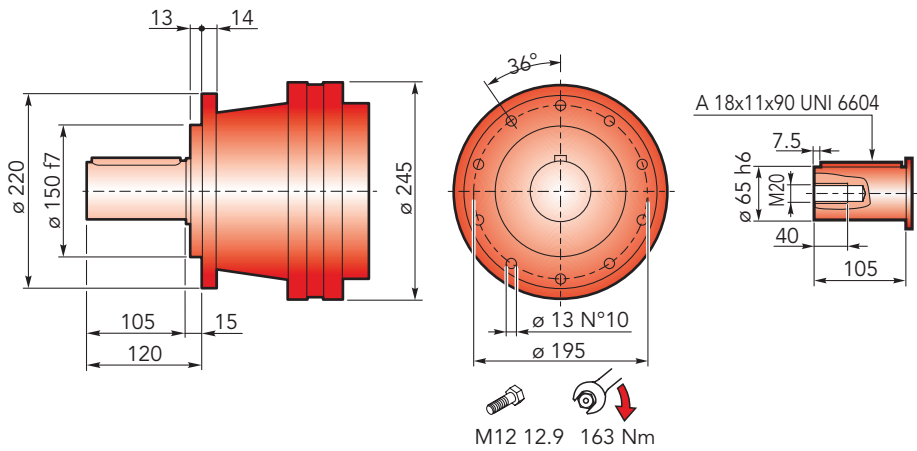

## CHPL 5000 CMC - Flange motori IEC

## CHPL 5000 CMC- IEC Motor flanges

CHPL	IEC 63			IEC 71			IEC 80			IEC 90			IEC 100		
	Lp	P	ØD	Lp	P	ØD	Lp	P	ØD	Lp	P	ØD	Lp	P	ØD
5001	213			213			233			233			243		
5002	274	36	140	274	36	160	294	56	200	294	56	200	304	66	250
5003	322			322			342			342			352		
5004	370			370			390			390			400		

CHPL	IEC 112			IEC 132			IEC 160			IEC 180		
	Lp	P	ØD	Lp	P	ØD	Lp	P	ØD	Lp	P	ØD
5001	243			277			316			316	139	350
5002	304	66	250	338	100	300	377	139	350	-	-	-
5003	352			386			425			-	-	-
5004	400			434			-			-	-	-

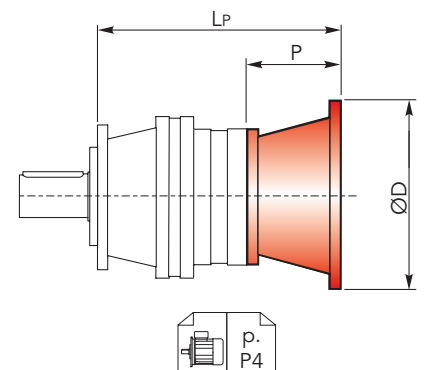

## CHPL 5000 CMC - Alberi maschi entrata

## CHPL 5000 CMC - Male input shafts

CHPL	CM42				CM65				CP65			
	Lt	T	Le	ØE	Lt	T	Le	ØE	Lt	T	Le	ØE
5001	270				312	121.5	105	65 h6	343.5	153	105	65 h6
5002	331	93	82	42 h6	-	-	-	-	-	-	-	-
5003	379				-	-	-	-	-	-	-	-
5004	427				-	-	-	-	-	-	-	-

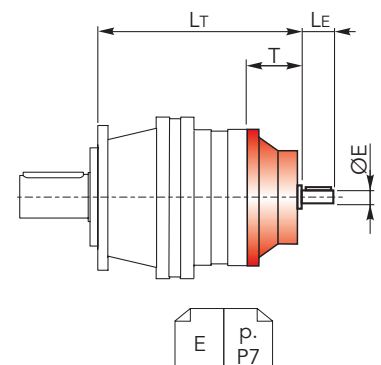



## DIMENSIONI CMC

## CMC DIMENSIONS

CHPL 5000 CMC - Riduttore a vite senza fine CHM in entrata CHPL 5000 CMC - CHM input worm gearboxes

CHPL	CHM 50					CHM 63				
	Lv	I	H	M	N	Lv	I	H	M	N
5001	302.5	50	110	60	80	312	63	135	72	95
5002	363.5					373				
5003	411.5					421				
5004	459.5					469				

CHPL	CHM 75					CHM 90				
	Lv	I	H	M	N	Lv	I	H	M	N
5001	291	75	161	86	112.5	301	90	193	103	129.5
5002	352					362				
5003	400					410				
5004	448					458				

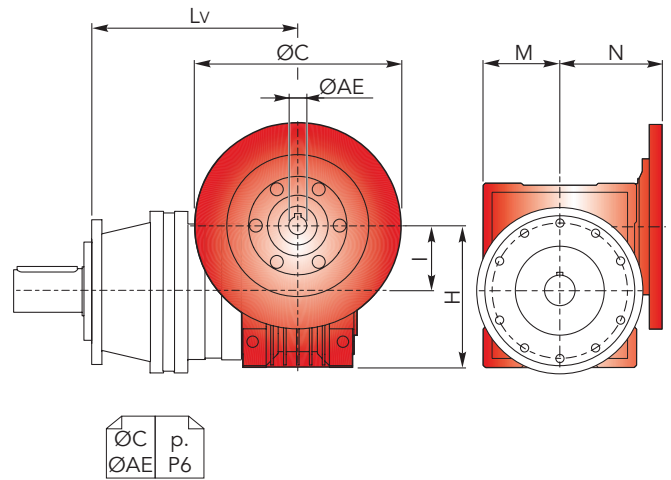

CHPL/CHPLB 5000

## CHPLB 5000 CMC - Flange motori IEC

## CHPLB 5000 CMC - IEC Motor flanges

CHPLB	IEC 63				IEC 71				IEC 80				IEC 90			
	L	LP	P	ØD	L	LP	P	ØD	L	LP	P	ØD	L	LP	P	ØD
5002	278.5	276	36	140	278.5	276	36	160	278.5	296	56	200	278.5	296	56	200
5003	313	196			313	196			313	216			313	216		
5004	361	361			361	361			361	361			361	361		

CHPLB	IEC 100				IEC 112				IEC 132				IEC 160			
	L	LP	P	ØD	L	LP	P	ØD	L	LP	P	ØD	L	LP	P	ØD
5002	278.5	306	66	250	278.5	306	66	250	278.5	340	100	300	278.5	379	139	350
5003	313	226			313	226			313	260			-	-		
5004	361	361			361	361			361	361			-	-		

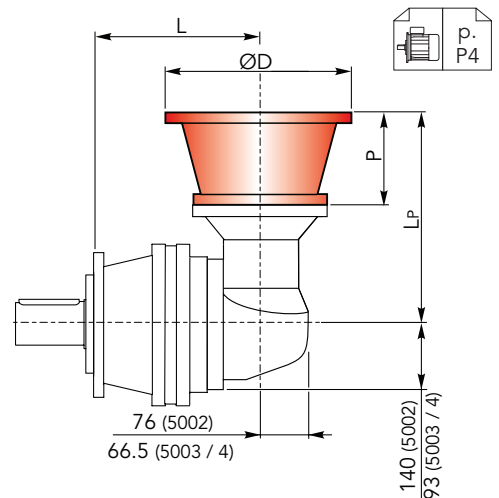

## CHPLB 5000 CMC - Alberi maschi entrata

## CHPL 5000 CMC - Male input shafts

CHPLB	CM42					CM65					CP65				
	L	Lt	T	Le	ØE	L	Lt	T	Le	ØE	L	Lt	T	Le	ØE
5002	278.5	333	93	82	42 h6	278.5	377.5	121.5	105	65 h6	278.5	409	153	105	65 h6
5003	313	253				313	297.5				313	329			
5004	361	361				361	361				361	361			

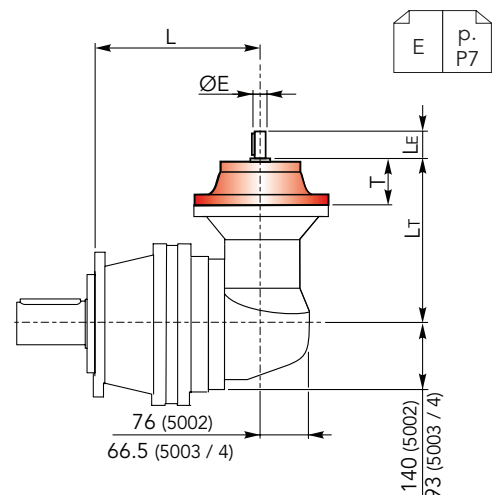



## DIMENSIONI CPS

## CPS DIMENSIONS

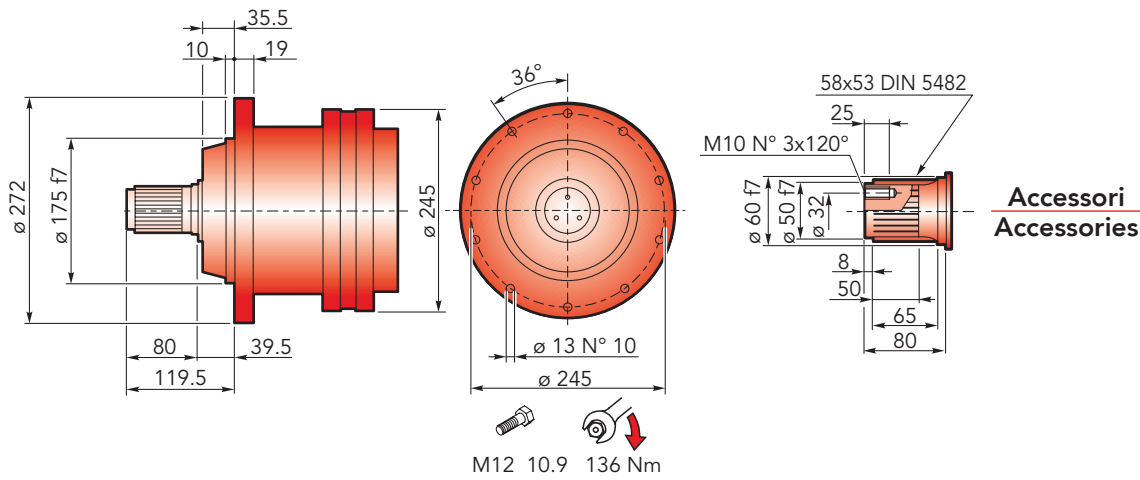

## CHPL 5000 CPS - Flange motori IEC

## CHPL 5000 CPS- IEC Motor flanges

CHPL	IEC 63			IEC 71			IEC 80			IEC 90			IEC 100		
	LP	P	ØD	LP	P	ØD	LP	P	ØD	LP	P	ØD	LP	P	ØD
5001	220			220			240			240			250		
5002	281	36	140	281	36	160	301	56	200	301	56	200	311	66	250
5003	329			329			349			349			359		
5004	377			377			397			397			407		

CHPL	IEC 112			IEC 132			IEC 160			IEC 180		
	LP	P	ØD	LP	P	ØD	LP	P	ØD	LP	P	ØD
5001	250			284			323			323	139	350
5002	311			345	100	300	384	139	350			-
5003	359	66	250	393			432					-
5004	407			441								-

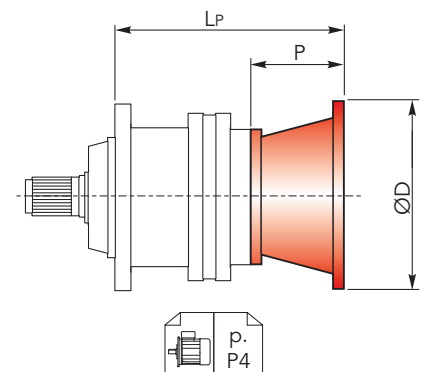

## CHPL 5000 CPS - Alberi maschi entrata

## CHPL 5000 CPS - Male input shafts

CHPL	CM42				CM65				CP65			
	LT	T	LE	ØE	LT	T	LE	ØE	LT	T	LE	ØE
5001	277				319	121.5	105	65 h6	350.5	153	105	65 h6
5002	338											
5003	386	93	82	42 h6								
5004	434											

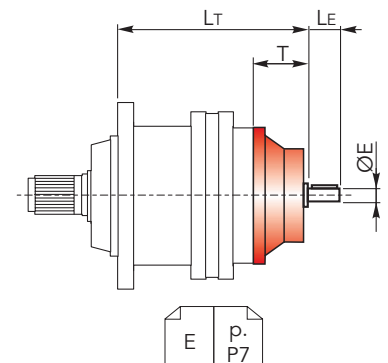



## DIMENSIONI CPS

## CPS DIMENSIONS

CHPL 5000 CPS - Riduttore a vite senza fine CHM in entrata

CHPL 5000 CPS - CHM input worm gearboxes

CHPL	CHM 50					CHM 63				
	Lv	I	H	M	N	Lv	I	H	M	N
5001	309.5	50	110	60	80	319	63	135	72	95
5002	370.5					380				
5003	418.5					428				
5004	466.5					476				

CHPL	CHM 75					CHM 90				
	Lv	I	H	M	N	Lv	I	H	M	N
5001	298	75	161	86	112.5	308	90	193	103	129.5
5002	359					369				
5003	407					417				
5004	455					465				

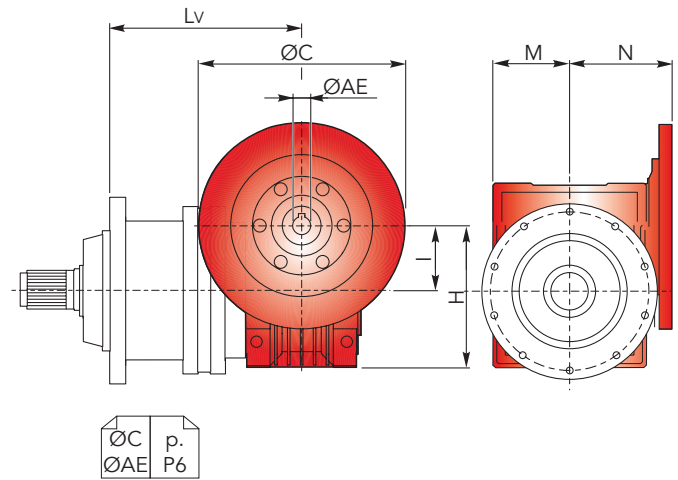

CHPL/CHPLB 5000

CHPLB 5000 CPS - Flange motori IEC

CHPLB 5000 CPS - IEC Motor flanges

CHPLB	IEC 63				IEC 71				IEC 80				IEC 90			
	L	LP	P	ØD	L	LP	P	ØD	L	LP	P	ØD	L	LP	P	ØD
5002	285.5	276	36	140	285.5	276	36	160	285.5	296	56	200	285.5	296	56	200
5003	320	196			320	196			320	216			320	216		
5004	368	368			368	368										

CHPLB	IEC 100				IEC 112				IEC 132				IEC 160			
	L	LP	P	ØD	L	LP	P	ØD	L	LP	P	ØD	L	LP	P	ØD
5002	285.5	306	66	250	285.5	306	66	250	285.5	340	100	300	285.5	379	139	350
5003	320	226			320	226			320	260			-			
5004	368	368			368	368			-							

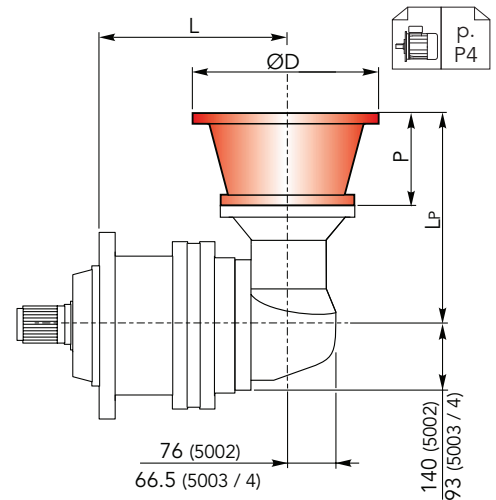

CHPLB 5000 CPS - Alberi maschi entrata

CHPL 5000 CPS - Male input shafts

CHPLB	CM42					CM65					CP65				
	L	L <sub>T</sub>	T	L <sub>E</sub>	ØE	L	L <sub>T</sub>	T	L <sub>E</sub>	ØE	L	L <sub>T</sub>	T	L <sub>E</sub>	ØE
5002	285.5	333	93	82	42 h6	285.5	377.5	121.5	105	65 h6	285.5	409	153	105	65 h6
5003	320	253				320	297.5				320	329			
5004	368	368				368	368								

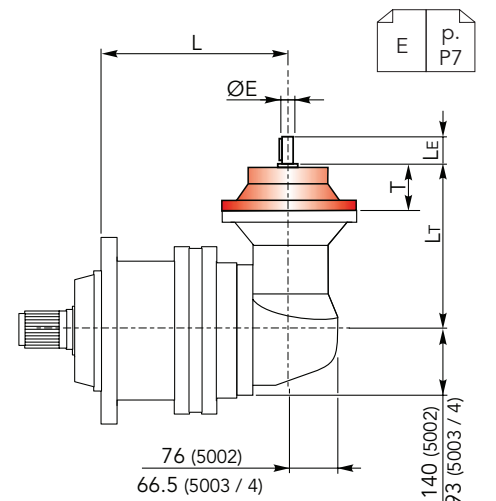



## DIMENSIONI CPC

## CPC DIMENSIONS

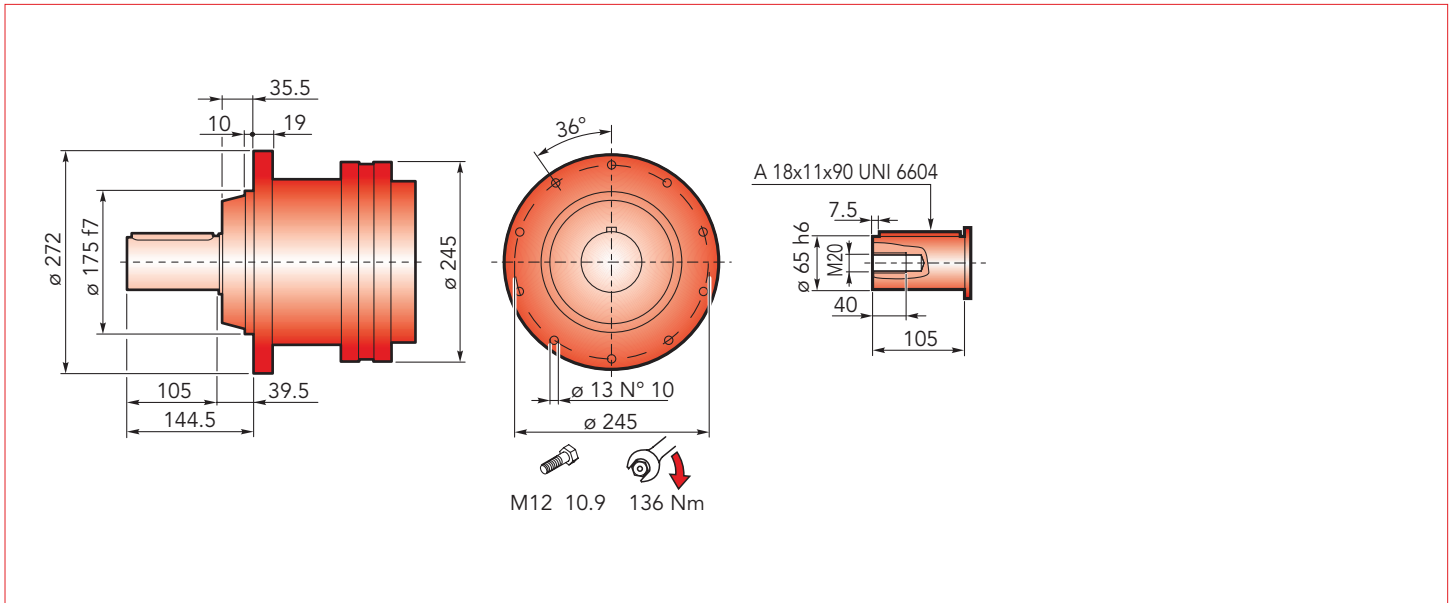

## CHPL 5000 CPC - Flange motori IEC

## CHPL 5000 CPC- IEC Motor flanges

CHPL	IEC 63			IEC 71			IEC 80			IEC 90			IEC 100		
	LP	P	ØD	LP	P	ØD	LP	P	ØD	LP	P	ØD	LP	P	ØD
5001	220			220			240			240			250		
5002	281	36	140	281	36	160	301	56	200	301	56	200	311	66	250
5003	329			329			349			349			359		
5004	377			377			397			397			407		

CHPL	IEC 112			IEC 132			IEC 160			IEC 180		
	LP	P	ØD	LP	P	ØD	LP	P	ØD	LP	P	ØD
5001	250			284			323			323	139	350
5002	311	66	250	345	100	300	384	139	350	-	-	-
5003	359			393			432			-	-	-
5004	407			441			-			-	-	-

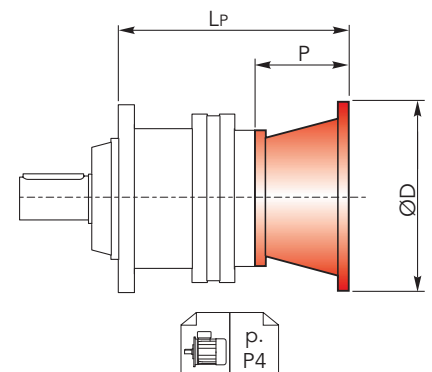

## CHPL 5000 CPC - Alberi maschi entrata

## CHPL 5000 CPC - Male input shafts

CHPL	CM42				CM65				CP65			
	LT	T	LE	ØE	LT	T	LE	ØE	LT	T	LE	ØE
5001	277				319	121	105	65 h6	350.5	153.5	105	65 h6
5002	338	93	82	42 h6	-	-	-	-	-	-	-	-
5003	386				-	-	-	-	-	-	-	-
5004	434				-	-	-	-	-	-	-	-

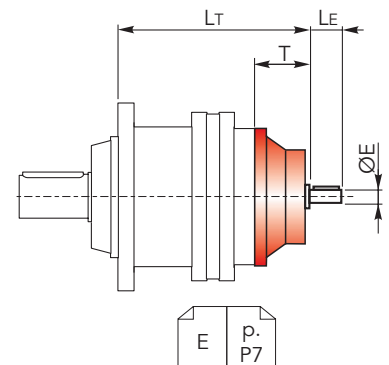





## DIMENSIONI CPC

## CPC DIMENSIONS

CHPL 5000 CPC - Riduttore a vite senza fine CHM in entrata

CHPL 5000 CPC - CHM input worm gearboxes

CHPL	CHM 50					CHM 63				
	Lv	I	H	M	N	Lv	I	H	M	N
5001	309.5	50	110	60	80	319	63	135	72	95
5002	370.5					380				
5003	418.5					428				
5004	466.5					476				

CHPL	CHM 75					CHM 90				
	Lv	I	H	M	N	Lv	I	H	M	N
5001	298	75	161	86	112.5	308	90	193	103	129.5
5002	359					369				
5003	407					417				
5004	455					465				

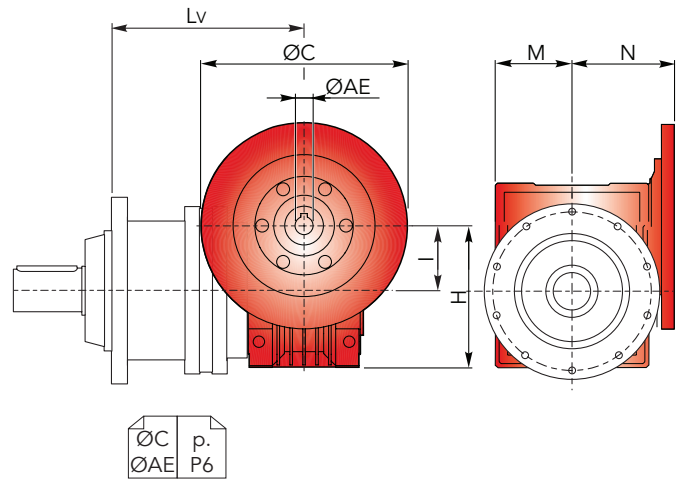

CHPL/CHPLB 5000

CHPLB 5000 CPC - Flange motori IEC

CHPLB 5000 CPC - IEC Motor flanges

CHPLB	IEC 63				IEC 71				IEC 80				IEC 90			
	L	LP	P	ØD	L	LP	P	ØD	L	LP	P	ØD	L	LP	P	ØD
5002	285.5	276	36	140	285.5	276	36	160	285.5	296	56	200	285.5	296	56	200
5003	320	196			320	196			320	216			320	216		
5004	368	368			368	368			368	368			368	368		

CHPLB	IEC 100				IEC 112				IEC 132				IEC 160			
	L	LP	P	ØD	L	LP	P	ØD	L	LP	P	ØD	L	LP	P	ØD
5002	285.5	306	66	250	285.5	306	66	250	285.5	340	100	300	285.5	379	139	350
5003	320	226			320	226			320	260			-	-		
5004	368	368			368	368			368	368			-	-		

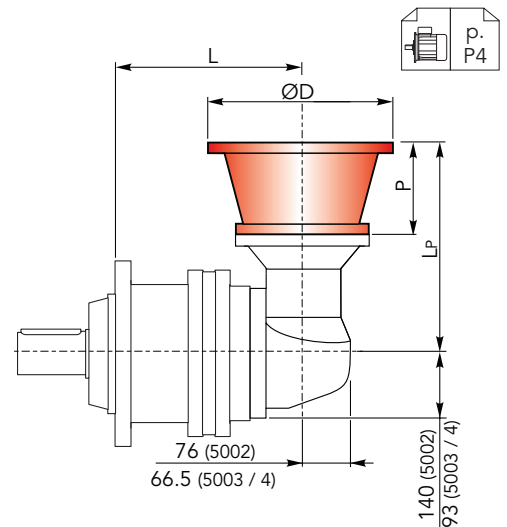

CHPLB 5000 CPC - Alberi maschi entrata

CHPL 5000 CPC - Male input shafts

CHPLB	CM42					CM65					CP65				
	L	L <sub>T</sub>	T	L <sub>E</sub>	ØE	L	L <sub>T</sub>	T	L <sub>E</sub>	ØE	L	L <sub>T</sub>	T	L <sub>E</sub>	ØE
5002	285.5	333	93	82	42 h6	285.5	377.5	121.5	105	65 h6	285.5	409	153	105	65 h6
5003	320	253				320	297.5				320	329			
5004	368	368				368	368				368	368			

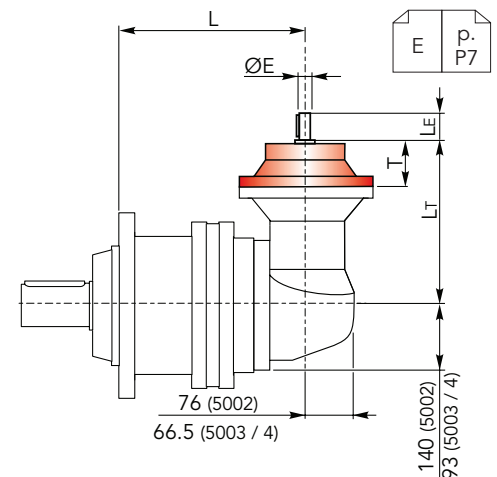



## DIMENSIONI CF

## CF DIMENSIONS

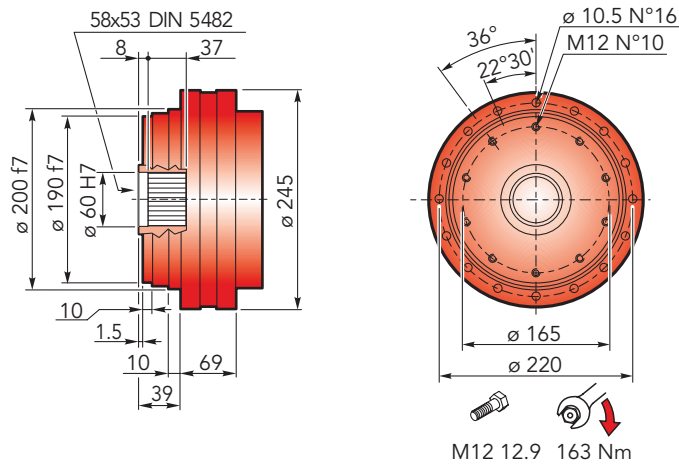

Accessori  
Accessories



## CHPL 5000 CF - Flange motori IEC

## CHPL 5000 CF - IEC Motor flanges

CHPL	IEC 63			IEC 71			IEC 80			IEC 90			IEC 100		
	LP	P	ØD	LP	P	ØD	LP	P	ØD	LP	P	ØD	LP	P	ØD
5001	126.5	36	140	126.5	36	160	146.5	56	200	146.5	56	200	156.5	66	250
5002	187.5			187.5			207.5			207.5			217.5		
5003	235.5			235.5			255.5			255.5			265.5		
5004	283.5			283.5			303.5			303.5			313.5		

CHPL	IEC 112			IEC 132			IEC 160			IEC 180		
	LP	P	ØD	LP	P	ØD	LP	P	ØD	LP	P	ØD
5001	156.5	66	250	190.5	100	300	229.5	139	350	229.5	139	350
5002	217.5			251.5			290.5			-		
5003	265.5			299.5			338.5			-		
5004	313.5			347.5			-			-		

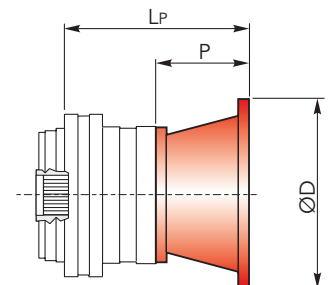

## CHPL 5000 CF - Alberi maschi entrata

## CHPL 5000 CF - Male input shafts

CHPL	CM42				CM65				CP65			
	LT	T	LE	ØE	LT	T	LE	ØE	LT	T	LE	ØE
5001	183.5	93	82	42 h6	225.5	121.5	105	65 h6	257	153	105	65 h6
5002	244.5				-	-	-					
5003	292.5				-	-	-					
5004	340.5				-	-	-					

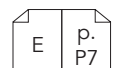
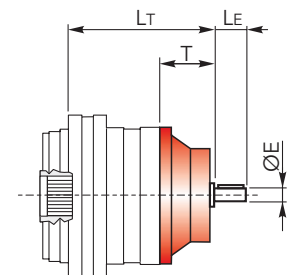



## DIMENSIONI CF

## CF DIMENSIONS

CHPL 5000 CF - Riduttore a vite senza fine CHM in entrata

CHPL 5000 CF - CHM input worm gearboxes

CHPL	CHM 50					CHM 63				
	Lv	I	H	M	N	Lv	I	H	M	N
5001	216	50	110	60	80	225.5	63	135	72	95
5002	277					286.5				
5003	325					334.5				
5004	373					382.5				

CHPL	CHM 75					CHM 90				
	Lv	I	H	M	N	Lv	I	H	M	N
5001	204.5	75	161	86	112.5	214.5	90	193	103	129.5
5002	265.5					275.5				
5003	313.5					323.5				
5004	361.5					371.5				

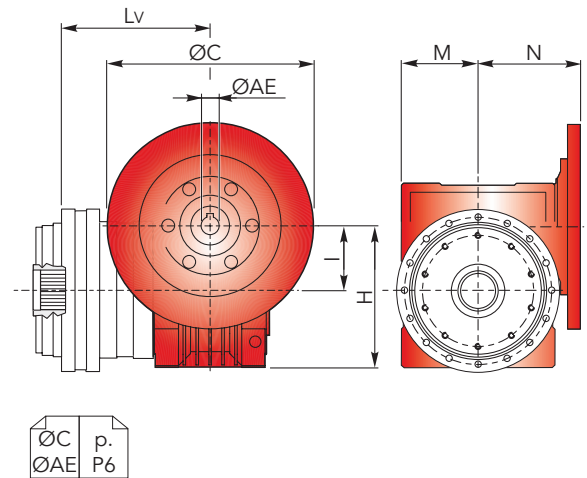

CHPLB 5000 CF - Flange motori IEC

CHPLB 5000 CF - IEC Motor flanges

CHPLB	IEC 63				IEC 71				IEC 80				IEC 90			
	L	LP	P	ØD	L	LP	P	ØD	L	LP	P	ØD	L	LP	P	ØD
5002	192	276	36	140	192	276	36	160	192	296	56	200	192	296	56	200
5003	226.5	196			226.5	196			226.5	216			226.5	216		
5004	274.5	274.5			274.5	274.5			274.5	274.5			274.5			

CHPLB	IEC 100				IEC 112				IEC 132				IEC 160			
	L	LP	P	ØD	L	LP	P	ØD	L	LP	P	ØD	L	LP	P	ØD
5002	192	306	66	250	192	306	66	250	192	340	100	300	192	379	139	350
5003	226.5	226			226.5	226			226.5	260			-			
5004	274.5	274.5			274.5	274.5			274.5	274.5			-			

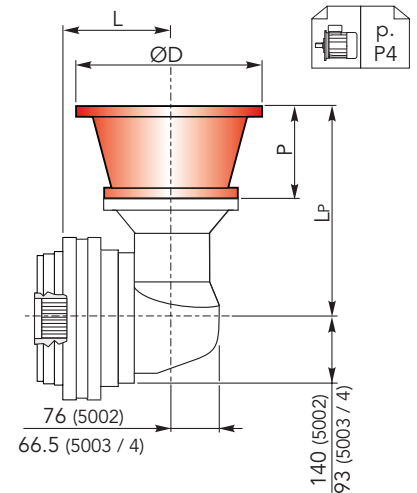

CHPLB 5000 CF - Alberi maschi entrata

CHPL 5000 CF - Male input shafts

CHPLB	CM42					CM65					CP65				
	L	Lt	T	Le	ØE	L	Lt	T	Le	ØE	L	Lt	T	Le	ØE
5002	192	333	93	82	42 h6	192	377.5	121.5	105	65 h6	192	409	153	105	65 h6
5003	226.5	253				226.5	297.5				226.5	329			
5004	274.5	274.5				274.5	274.5				274.5	274.5			

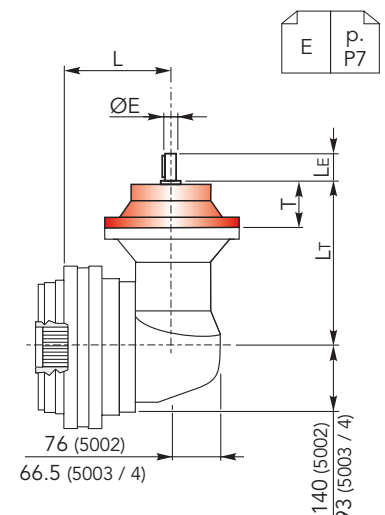



## DIMENSIONI CFS

## CFS DIMENSIONS

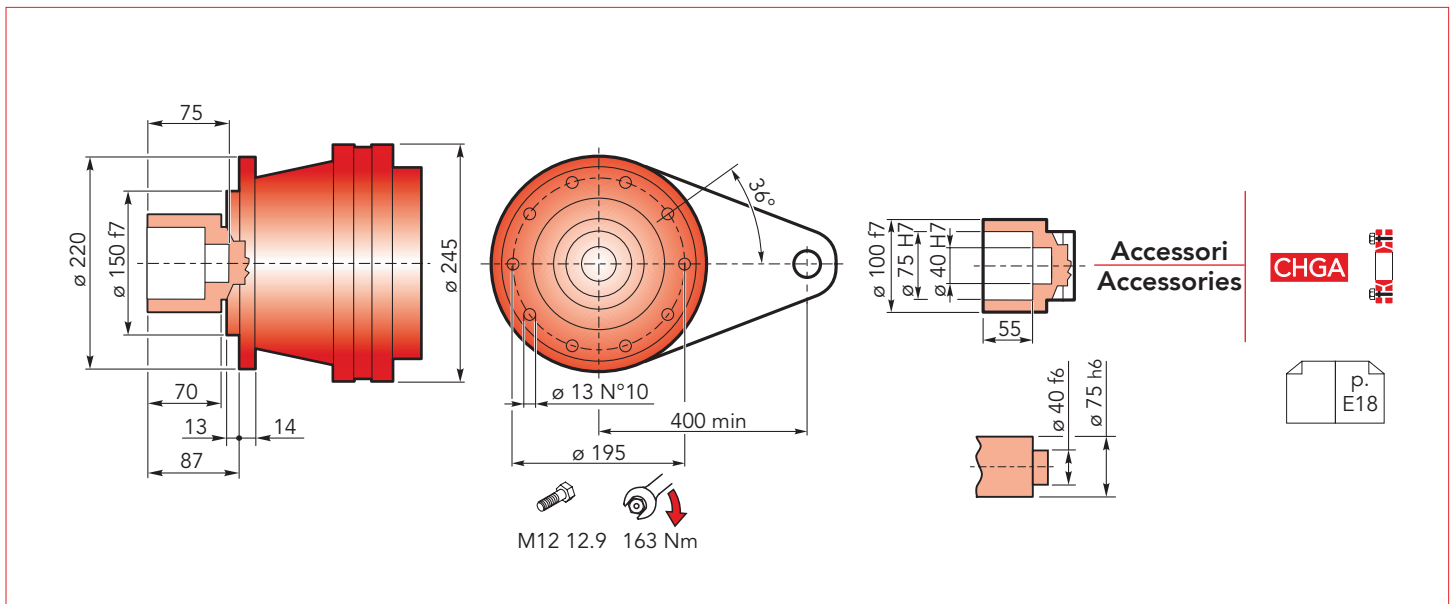

## CHPL 5000 CFS - Flange motori IEC

## CHPL 5000 CFS- IEC Motor flanges

CHPL	IEC 63			IEC 71			IEC 80			IEC 90			IEC 100		
	Lp	P	ØD	Lp	P	ØD	Lp	P	ØD	Lp	P	ØD	Lp	P	ØD
5001	213			213			233			233			243		
5002	274	36	140	274	36	160	294	56	200	294	56	200	304	66	250
5003	322			322			342			342			352		
5004	370			370			390			390			400		

CHPL	IEC 112			IEC 132			IEC 160			IEC 180		
	Lp	P	ØD	Lp	P	ØD	Lp	P	ØD	Lp	P	ØD
5001	243			277			316			316	139	350
5002	304	66	250	338	100	300	377	139	350	-	-	-
5003	352			386			425			-	-	-
5004	400			434			-			-	-	-

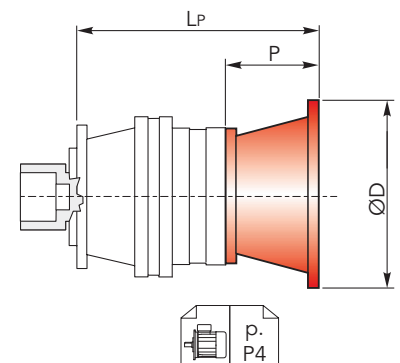

## CHPL 5000 CFS - Alberi maschi entrata

## CHPL 5000 CFS - Male input shafts

CHPL	CM42				CM65				CP65			
	Lt	T	Le	ØE	Lt	T	Le	ØE	Lt	T	Le	ØE
5001	270				312	121.5	105	65 h6	343.5	153	105	65 h6
5002	331	93	82	42 h6	-	-	-	-	-	-	-	-
5003	379				-	-	-	-	-	-	-	-
5004	427				-	-	-	-	-	-	-	-

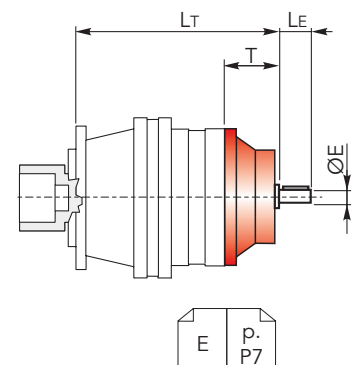



## DIMENSIONI CFS

## CFS DIMENSIONS

CHPL 5000 CFS - Riduttore a vite senza fine CHM in entrata

CHPL 5000 CFS - CHM input worm gearboxes

CHPL	CHM 50					CHM 63				
	Lv	I	H	M	N	Lv	I	H	M	N
5001	302.5	50	110	60	80	312	63	135	72	95
5002	363.5					373				
5003	411.5					421				
5004	459.5					469				

CHPL	CHM 75					CHM 90				
	Lv	I	H	M	N	Lv	I	H	M	N
5001	291	75	161	86	112.5	301	90	193	103	129.5
5002	352					362				
5003	400					410				
5004	448					458				

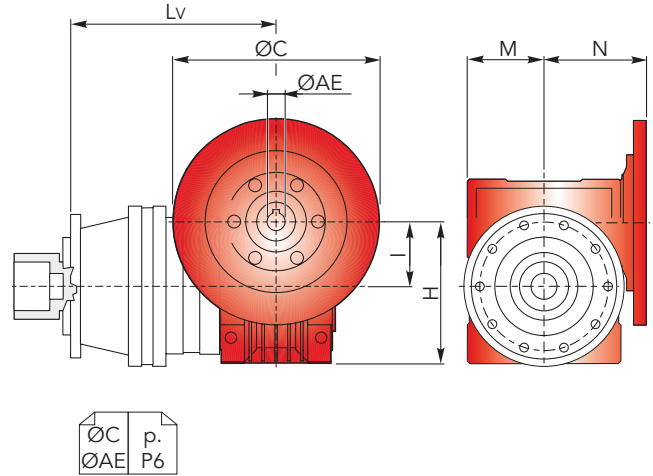

CHPL/CHPLB 5000

CHPLB 5000 CFS - Flange motori IEC

CHPLB 5000 CFS - IEC Motor flanges

CHPLB	IEC 63				IEC 71				IEC 80				IEC 90			
	L	LP	P	ØD	L	LP	P	ØD	L	LP	P	ØD	L	LP	P	ØD
5002	278.5	276	36	140	278.5	276	36	160	278.5	296	56	200	278.5	296	56	200
5003	313	196			313	196			313	216			313	216		
5004	361	361			361	361			361	361			361	361		

CHPLB	IEC 100				IEC 112				IEC 132				IEC 160			
	L	LP	P	ØD	L	LP	P	ØD	L	LP	P	ØD	L	LP	P	ØD
5002	278.5	306	66	250	278.5	306	66	250	278.5	340	100	300	278.5	379	139	350
5003	313	226			313	226			313	260			-			
5004	361	361			361	361			361	361			-			

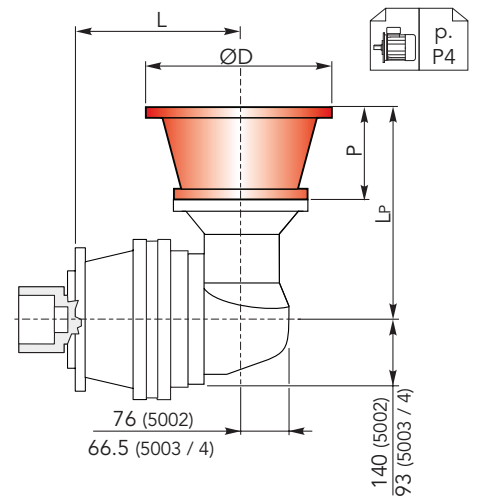

CHPLB 5000 CFS - Alberi entrata

CHPL 5000 CFS - Male input shafts

CHPLB	CM42					CM65					CP65				
	L	LT	T	LE	ØE	L	LT	T	LE	ØE	L	LT	T	LE	ØE
5002	278.5	333	93	82	42 h6	278.5	377.5	121.5	105	65 h6	278.5	409	153	105	65 h6
5003	313	253				313	297.5				313	329			
5004	361	361				361	361				361	361			

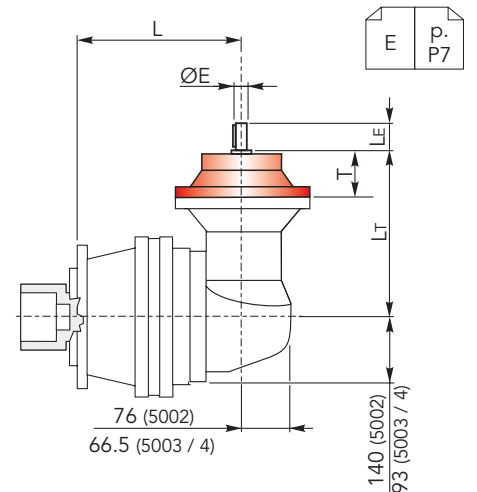



## DIMENSIONI CCPC

## CCPC DIMENSIONS

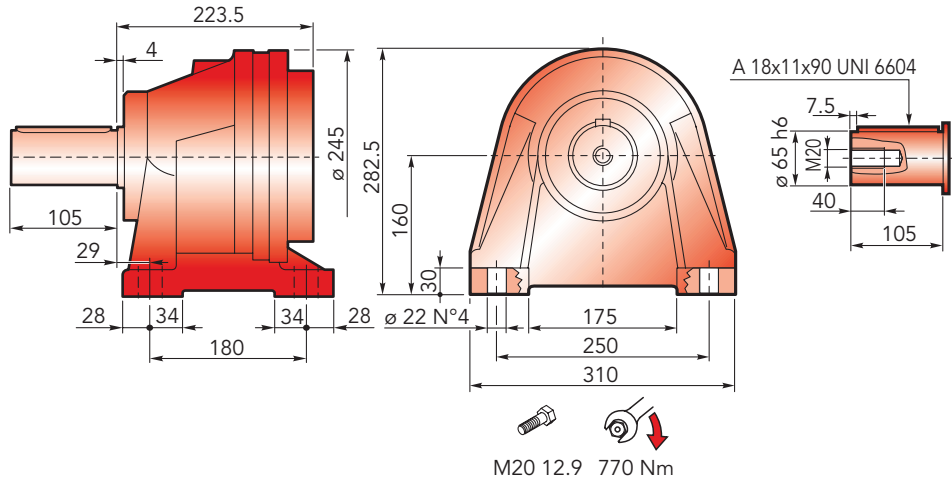

## CHPL 5000 CCPC - Flange motori IEC

## CHPL 5000 CCPC- IEC Motor flanges

CHPL	IEC 63			IEC 71			IEC 80			IEC 90			IEC 100		
	Lp	P	ØD	Lp	P	ØD	Lp	P	ØD	Lp	P	ØD	Lp	P	ØD
5001	259.5			259.5			279.5			279.5			289.5		
5002	320.5	36	140	320.5	36	160	340.5	56	200	340.5	56	200	350.5	66	250
5003	368.5			368.5			388.5			388.5			398.5		
5004	416.5			416.5			436.5			436.5			446.5		

CHPL	IEC 112			IEC 132			IEC 160			IEC 180		
	Lp	P	ØD	Lp	P	ØD	Lp	P	ØD	Lp	P	ØD
5001	289.5			323.5			362.5			362.5	139	350
5002	350.5	66	250	384.5	100	300	423.5	139	350	-		
5003	398.5			432.5			-					
5004	446.5			480.5			-					

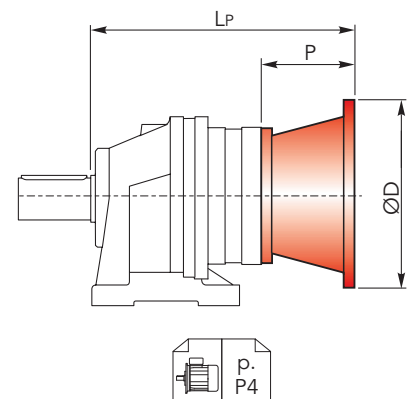

## CHPL 5000 CCPC - Alberi maschi entrata

## CHPL 5000 CCPC - Male input shafts

CHPL	CM42				CM65				CP65			
	Lt	T	Le	ØE	Lt	T	Le	ØE	Lt	T	Le	ØE
5001	316.5				358.5	121.5	105	65 h6	390	153	105	65 h6
5002	377.5	93	82	42 h6	-				-			
5003	425.5				-				-			
5004	473.5				-				-			

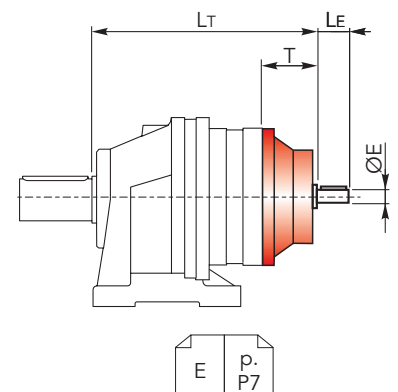



## DIMENSIONI CCPC

## CCPC DIMENSIONS

CHPL 5000 CCPC - Riduttore a vite senza fine CHM in entrata CHPL 5000 CCPC - CHM input worm gearboxes

CHPL	CHM 50					CHM 63				
	Lv	I	H	M	N	Lv	I	H	M	N
5001	349	50	110	60	80	358.5	63	135	72	95
5002	410					419.5				
5003	458					467.5				
5004	506					515.5				

CHPL	CHM 75					CHM 90				
	Lv	I	H	M	N	Lv	I	H	M	N
5001	337.5	75	161	86	112.5	347.5	90	193	103	129.5
5002	398.5					408.5				
5003	446.5					456.5				
5004	494.5					504.5				

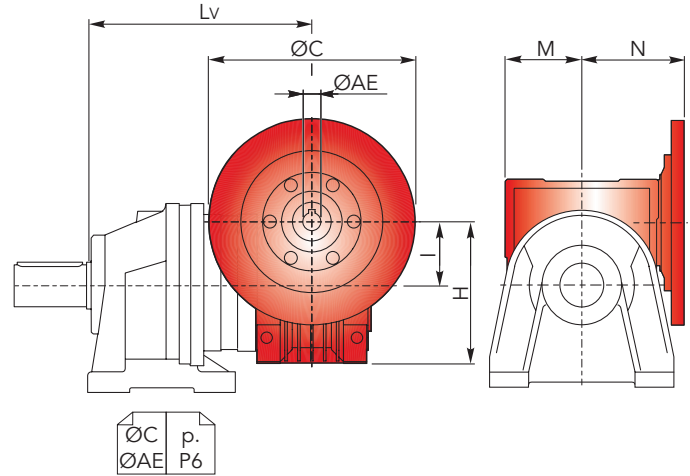

CHPL/CHPLB 5000

## CHPLB 5000 CCPC - Flange motori IEC

## CHPLB 5000 CCPC - IEC Motor flanges

CHPLB	IEC 63				IEC 71				IEC 80				IEC 90			
	L	LP	P	ØD	L	LP	P	ØD	L	LP	P	ØD	L	LP	P	ØD
5002	325	276	36	140	325	276	36	160	325	296	56	200	325	296	56	200
5003	359.5	196			359.5	196			359.5	216			359.5	216		
5004	407.5	407.5			407.5	407.5			407.5	407.5						

CHPLB	IEC 100				IEC 112				IEC 132				IEC 160			
	L	LP	P	ØD	L	LP	P	ØD	L	LP	P	ØD	L	LP	P	ØD
5002	325	306	66	250	325	306	66	250	325	340	100	300	325	379	139	350
5003	359.5	226			359.5	226			359.5	260			-			
5004	407.5	407.5			407.5	407.5			407.5	407.5			-			

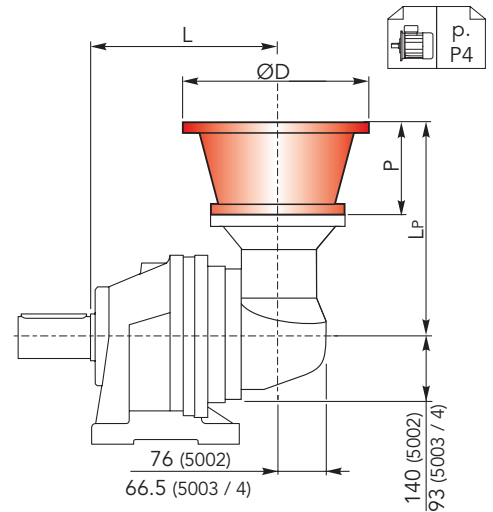

## CHPLB 5000 CCPC - Alberi maschi entrata

## CHPL 5000 CCPC - Male input shafts

CHPLB	CM42					CM65					CP65				
	L	LT	T	LE	ØE	L	LT	T	LE	ØE	L	LT	T	LE	ØE
5002	325	333	93	82	42 h6	325	377.5	121.5	105	65 h6	325	409	153	105	65 h6
5003	359.5	253				359.5	297.5				359.5	329			
5004	407.5	407.5				407.5	407.5				407.5	407.5			

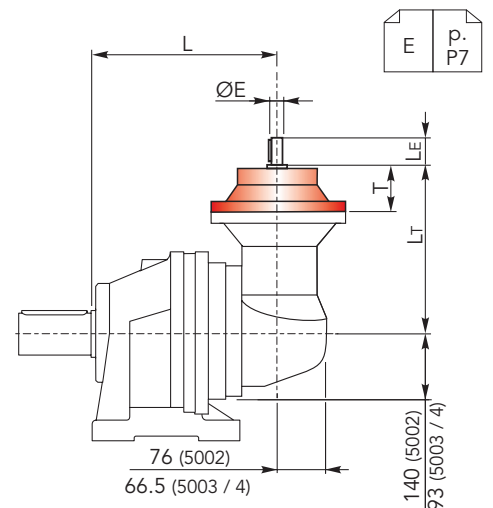



## ACCESSORI

## ACCESSORIES

CHYZ



Pignoni / Pinions

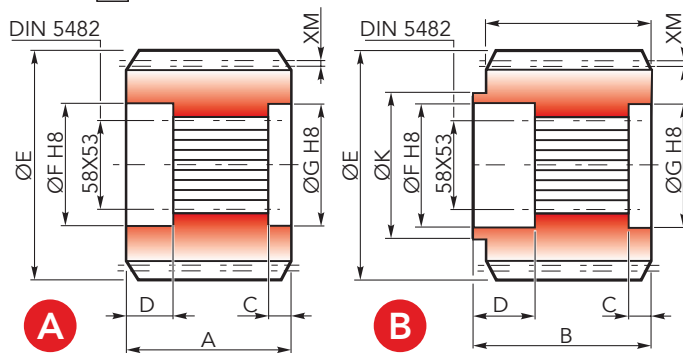

	Uscita / Output	M	Z	XM	A	B	C	D	E	F	G	K	Codice / Code
A	CMS	8	13	0	68	-	8.5	22.5	120	60	60	-	1071.218.042
	CMS	8	11	5	68	-	8.5	22.5	110.8	60	60	-	1071.258.042
	CMS	8	12	0	68	-	8	21	112.8	60	60	-	1071.196.042
	CMS	8	15	0	686	-	8.5	22.5	136	60	60	-	1071.163.042
	CPS	6	14	3	95	.	23	21	99.6	60	60	-	1071.160.042
	CPS	10	11	8	90	-	8.5	22.5	142.1	60	60	-	1071.297.042
B	CPS	10	14	3.2	103	116	9.5	22.5	162.4	60	60	105	1071.298.042

CHFF

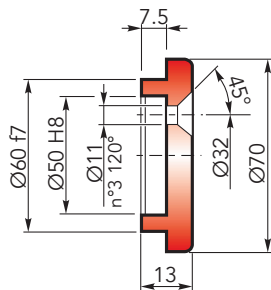

Fondello di arresto / Stop bottom plate

Codice / Code:  
1075.015.000

CHBS

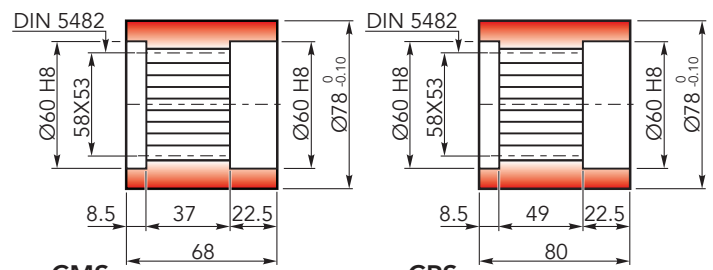

Boccola scanalata / Splined bushing

CMS  
Codice / Code:  
2171.101.076CPS  
Codice / Code:  
4171.101.076

CHKB

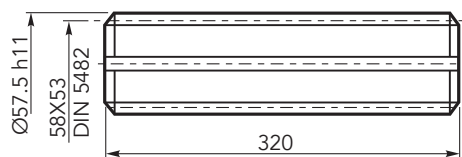

Barra scanalata / Splined rod

Codice / Code:  
3071.181.042

CHGA

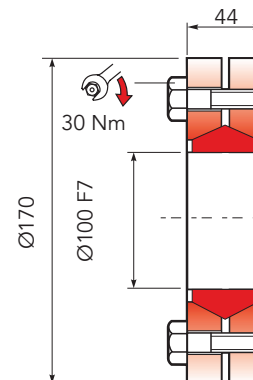

Giunto di attrito / Shrink disc

Coppia max: 7500 Nm (1)  
Max Torque: 7500 Nm (1)Codice / Code:  
5109.100.000

(1): Coppia max indicata è valida solo con calettatori forniti da Chiaravalli S.p.A.

(1): The maximum torque indicated is valid only with shrink discs supplied by Chiaravalli S.p.A.

CHFL



Flangia / Flange

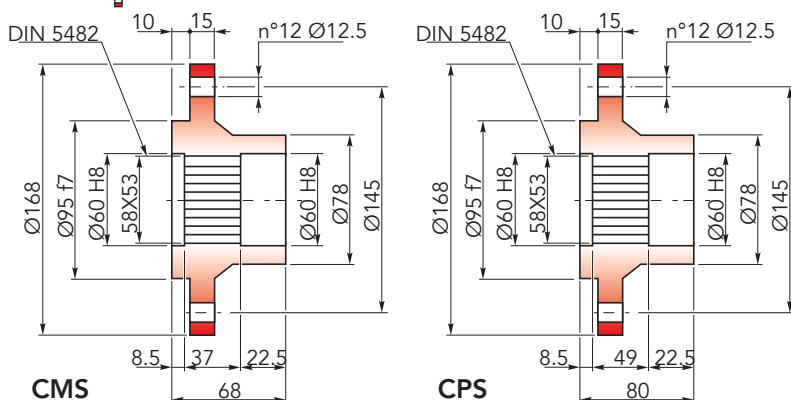

CMS

Codice / Code:  
2171.103.025

CPS

Codice / Code:  
4171.103.098





## CARICHI RADIALI (Fr)

Nel diagramma seguente, sono indicati i carichi radiali Fr (N) applicabili sull'albero uscita in funzione della distanza di applicazione L rispetto alla battuta dell'albero.

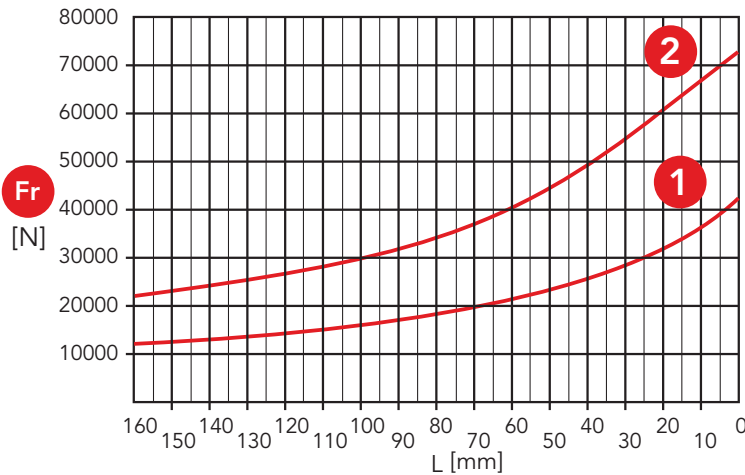

## RADIAL LOADS (Fr)

The hereunder table shows the allowable radial loads Fr (N) on the output shaft with reference to the distance L.

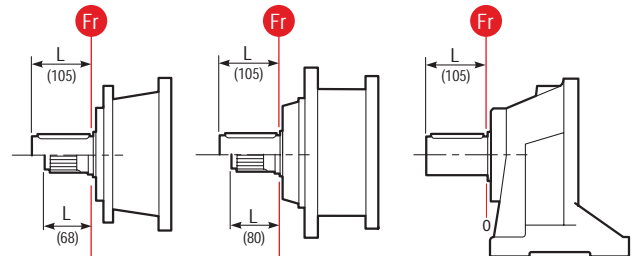

- 1** Uscita / Output: CMS, CMC
- 2** Uscita / Output: CPS, CPC, CCPC

## CARICHI ASSIALI (Fa)

Nella tabella seguente sono indicati i carichi assiali Fa (N) applicabili sull'albero di uscita in funzione della direzione di applicazione del carico e della versione.

	<b>1</b>	<b>2</b>	
<b>Fa</b> [N]	32000	32000	←
	32000	48000	→

## AXIAL LOADS (Fa)

The hereunder table shows the allowable axial loads Fa (N) on the output shaft with reference to the load direction and the output type.

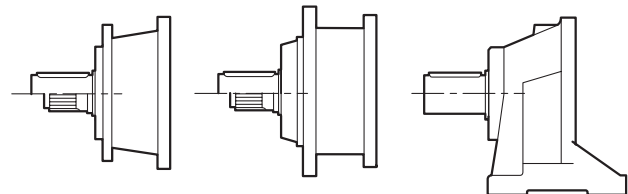





- 1** Uscita / Output: CMS, CMC
- 2** Uscita / Output: CPS, CPC, CCPC



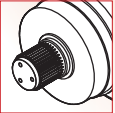
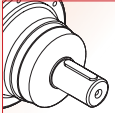
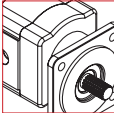
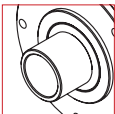
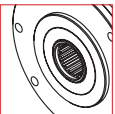
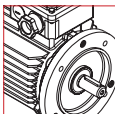
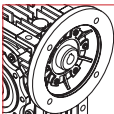

# CHPL/CHPLB 7000

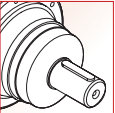
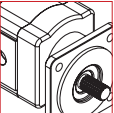
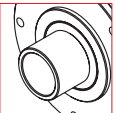
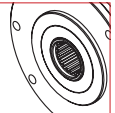
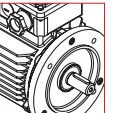
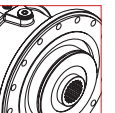

	<b>i</b>	<b>T<sub>2n</sub></b> (daNm)	<b>OUT</b>		<b>IN</b>	
<b>7001</b>	3.67 ÷ 7.00	281.2 ÷ 513.0	 Ø80	 70X64 DIN 5482	 Ø42 Ø65	 Hydraulic Motor
<b>7002</b>	13.9 ÷ 50.8	281.2 ÷ 513.0	 Ø90	 70X64 DIN 5482	 Electric Motor	 Worm gearboxes
<b>7003</b>	53.8 ÷ 342.6	281.2 ÷ 513.0				
<b>7004</b>	301.1 ÷ 2968.9	281.2 ÷ 513.0			 Brake	

	<b>i</b>	<b>T<sub>2n</sub></b> (daNm)	<b>OUT</b>		<b>IN</b>	
<b>7002</b>	12.7 ÷ 38.1	281.2 ÷ 513.0	 Ø80	 70X64 DIN 5482	 Ø42 Ø65	 Hydraulic Motor
<b>7003</b>	53.6 ÷ 148.9	281.2 ÷ 468.4	 Ø90	 70X64 DIN 5482	 Electric Motor	
<b>7004</b>	157.7 ÷ 1069.0	347.7 ÷ 513.0			 Brake	

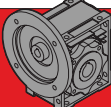

## DATI TECNICI

## TECHNICAL DATA



 <b>CHPL</b>	i	$T_{2n}$ ( $n_1=1400$ rpm) [daNm]	$P_{1n}$ ( $n_1=1400$ rpm) [kW]	$P_t$ [kW]	IEC		 <b>CHM</b>	 <b>CM / CP</b>
					(B5)			
<b>7001</b>	3.67	513.0	205	30	160 200	180	CHM 110	CM65 CP65
	4.43	468.4	155					
	5	410.4	120					
	5.8	347.7	88					
	7	281.2	59					
<b>7002</b>	13.9	513.0	54	18	63 80 100 132 180	71 90 112 160	CHM 50 CHM 63 CHM 75 CHM 90 CHM 110	CM42 CM65 CP65
	18.3	468.4	38					
	20.6	410.4	29					
	22.9	468.4	30					
	26.6	468.4	26					
	30	410.4	20					
	36.3	410.4	17					
	42.1	347.7	12					
	50.8	281.2	8.1					
	53.8	513.0	14					
<b>7003</b>	64.8	513.0	12	14	63 80 100 132	71 90 112 160	CHM 50 CHM 63 CHM 75 CHM 90	CM42
	71.7	468.4	9.6					
	78.3	468.4	8.8					
	88.4	410.4	6.8					
	93.7	468.4	7.3					
	102.1	513.0	7.4					
	112.9	468.4	6.1					
	127.9	513.0	5.9					
	139.2	410.4	4.3					
	148.8	468.4	4.6					
	155.4	410.4	3.9					
	174.4	410.4	3.4					
	194.9	347.7	2.6					
	216.7	468.4	3.2					
	244.7	410.4	2.5					
	283.8	347.7	1.8					
	342.6	281.2	1.2					
<b>7004</b>	301.1	513.0	2.5	8	63 80 100 132	71 90 112	CHM 50 CHM 63 CHM 75 CHM 90	CM42
	332.4	513.0	2.3					
	347.9	513.0	2.2					
	400.7	513.0	1.9					
	434.4	513.0	1.7					
	474.3	513.0	1.6					
	523.6	513.0	1.4					
	571.7	513.0	1.3					
	632.4	468.4	1.1					
	661.9	468.4	1.0					
	747.3	410.4	0.81					
	768.7	468.4	0.89					
	832.3	468.4	0.82					
	870	410.4	0.69					
	976.5	410.4	0.62					
	1048.7	410.4	0.57					
	1177	410.4	0.51					
	1366.9	410.4	0.44					
	1651.6	410.4	0.36					
	2968.9	281.2	0.14					

 $n_{1max} = 2800$  rpm

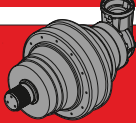

## DATI TECNICI

## TECHNICAL DATA

 CHPLB	i	T <sub>2n</sub> (n <sub>1</sub> =1400 rpm)	P <sub>1n</sub> (n <sub>1</sub> =1400 rpm)	P <sub>t</sub>	IEC	 CM / CP
		[daNm]	[kW]	[kW]	(B5)	
<b>7002</b>	12.7	513.0	59	18	63   71 80   90 100   112 132   160 180	CM42 CM65 CP65
	15.3	468.4	45			
	17.3	410.4	35			
	20	347.7	25			
	24.1	468.4	28			
	27.2	410.4	22			
	31.6	347.7	16			
	38.1	281.2	11			
<b>7003</b>	53.6	468.4	13	14	63   71 80   90 100   112 132   160	CM42 CM65 CP65
	55.6	468.4	12			
	60.5	410.4	9.9			
	67.1	468.4	10			
	77.9	468.4	8.8			
	88	410.4	6.8			
	94.2	468.4	7.3			
	106.3	410.4	5.7			
	123.3	347.7	4.1			
	148.9	281.2	2.8			
<b>7004</b>	157.7	513.0	4.8	8	63   71 80   90 100   112 132	CM42 CM65 CP65
	174.1	513.0	4.3			
	190.1	513.0	4.0			
	210.3	468.4	3.3			
	229.6	468.4	3.0			
	248.4	513.0	3.0			
	274.8	468.4	2.5			
	300.1	468.4	2.3			
	331.2	468.4	2.1			
	361.7	468.4	1.9			
	393	347.7	1.3			
	453	468.4	1.5			
	511.5	410.4	1.2			
	557	347.7	0.92			
	594	410.4	1.0			
	656.7	410.4	0.92			
	717.7	410.4	0.84			
	832.6	347.7	0.61			
921.5	410.4	0.65				
1069	347.7	0.48				

n<sub>1max</sub> = 2800 rpm

CHPL/CHPLB 7000



## DIMENSIONI CPS

## CPS DIMENSIONS

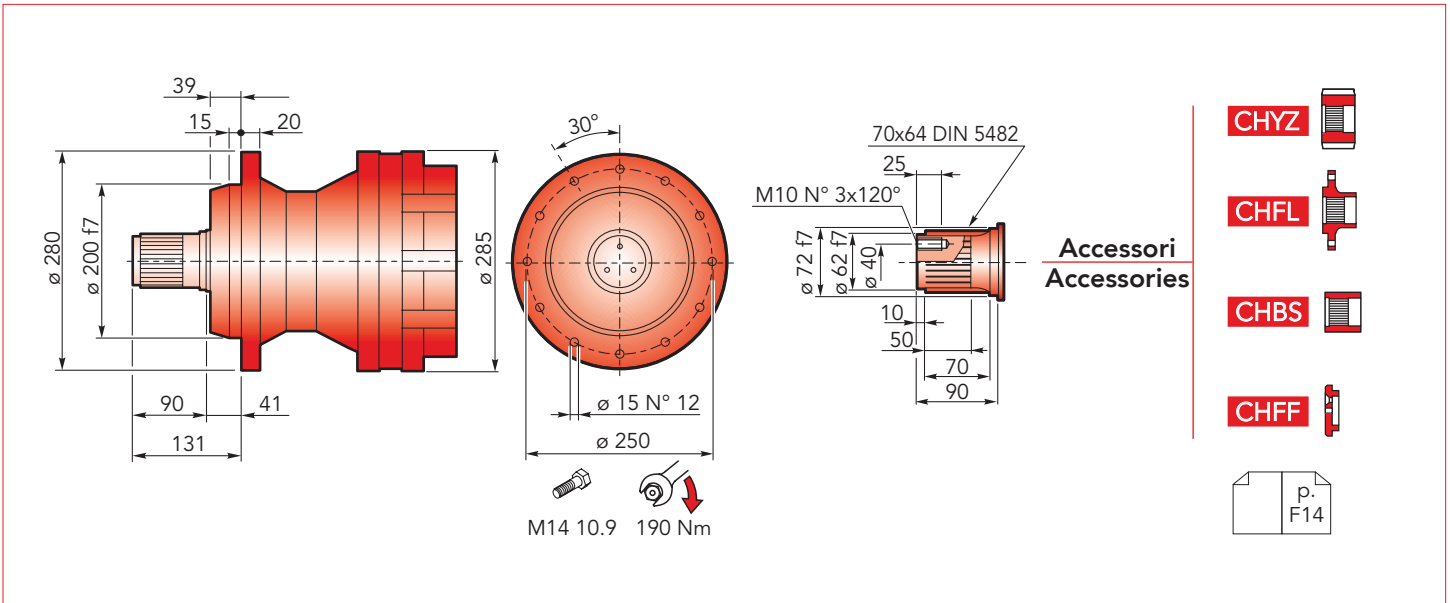

### CHPL 7000 CPS - Flange motori IEC

### CHPL 7000 CPS- IEC Motor flanges

CHPL	IEC 63			IEC 71			IEC 80			IEC 90			IEC 100		
	LP	P	ØD	LP	P	ØD	LP	P	ØD	LP	P	ØD	LP	P	ØD
7001	-	-	-	-	-	-	-	-	-	-	-	-	-	-	-
7002	345.5	-	-	345.5	-	-	365.5	-	-	365.5	-	-	375.5	-	-
7003	393.5	36	140	393.5	36	160	413.5	56	200	413.5	56	200	423.5	66	250
7004	441.5	-	-	441.5	-	-	461.5	-	-	461.5	-	-	471.5	-	-

CHPL	IEC 112			IEC 132			IEC 160			IEC 180			IEC 200		
	LP	P	ØD	LP	P	ØD	LP	P	ØD	LP	P	ØD	LP	P	ØD
7001	-	-	-	-	-	-	368	118	350	368	118	350	398	148	400
7002	375.5	-	-	409.5	-	-	448.5	-	350	448.5	139	350	-	-	-
7003	423.5	66	250	457.5	100	300	496.5	-	-	-	-	-	-	-	-
7004	471.5	-	-	505.5	-	-	-	-	-	-	-	-	-	-	-

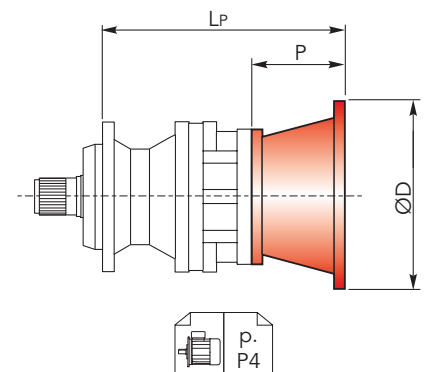

### CHPL 7000 CPS - Alberi maschi entrata

### CHPL 7000 CPS - Male input shafts

CHPL	CM42				CM65				CP65			
	LT	T	LE	ØE	LT	T	LE	ØE	LT	T	LE	ØE
7001	-	-	-	-	371.5	-	-	-	403	-	-	-
7002	402.5	-	-	-	444.5	121.5	105	65 h6	476	153	105	65 h6
7003	450.5	93	82	42 h6	-	-	-	-	-	-	-	-
7004	498.5	-	-	-	-	-	-	-	-	-	-	-

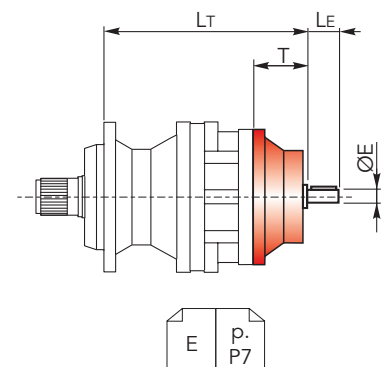



## DIMENSIONI CPS

## CPS DIMENSIONS

CHPL 7000 CPS - Riduttore a vite senza fine CHM in entrata

CHPL 7000 CPS - CHM input worm gearboxes

CHPL	CHM 50					CHM 63				
	Lv	I	H	M	N	Lv	I	H	M	N
7001	-					-				
7002	435					444.5				
7003	483	50	110	60	80	492.5	63	135	72	95
7004	531					540.5				

CHPL	CHM 75					CHM 90					CHM 110				
	Lv	I	H	M	N	Lv	I	H	M	N	Lv	I	H	M	N
7001	-					-					388				
7002	423.5					433.5					461	110	237.5	127.5	160
7003	471.5	75	161	86	112.5	481.5	90	193	103	129.5					
7004	519.5					529.5									

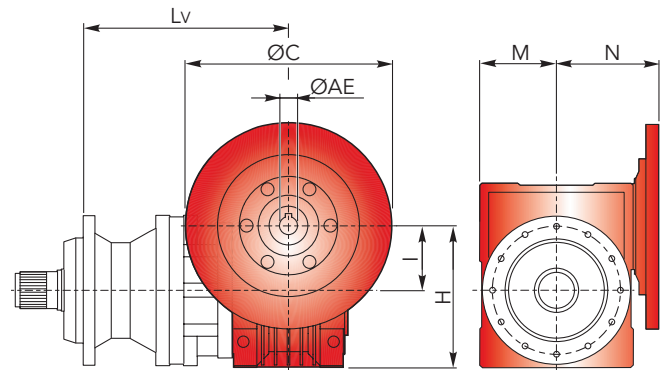

CHPL/CHPLB 7000

CHPLB 7000 CPS - Flange motori IEC

CHPLB 7000 CPS - IEC Motor flanges

CHPLB	IEC 63				IEC 71				IEC 80				IEC 90			
	L	Lp	P	ØD	L	Lp	P	ØD	L	Lp	P	ØD	L	Lp	P	ØD
7002	338	276			338	276			338	296			338	296		
7003	384.5	196	36	140	384.5	196	36	160	384.5	216	56	200	384.5	216	56	200
7004	432.5				432.5				432.5				432.5			

CHPLB	IEC 100				IEC 112				IEC 132				IEC 160				IEC 180			
	L	Lp	P	ØD	L	Lp	P	ØD	L	Lp	P	ØD	L	Lp	P	ØD	L	Lp	P	ØD
7002	338	306			338	306			338	340			338	379	139	350	338	379	139	350
7003	384.5	226	66	250	384.5	226	66	250	384.5	260	100	300	384.5	299						
7004	432.5				432.5				432.5											

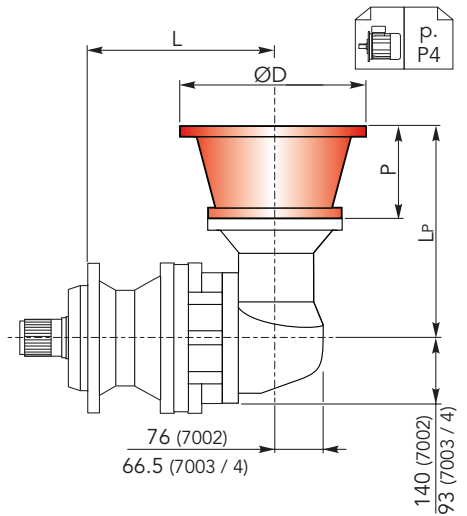

CHPLB 7000 CPS - Alberi maschi entrata

CHPL 7000 CPS - Male input shafts

CHPLB	CM42					CM65					CP65				
	L	Lt	T	Le	ØE	L	Lt	T	Le	ØE	L	Lt	T	Le	ØE
7002	338	333				338	377.5				338	409			
7003	384.5	253	93	82	42 h6	384.5	297.5	121.5	105	65 h6	384.5	329	153	105	65 h6
7004	432.5					432.5					432.5				

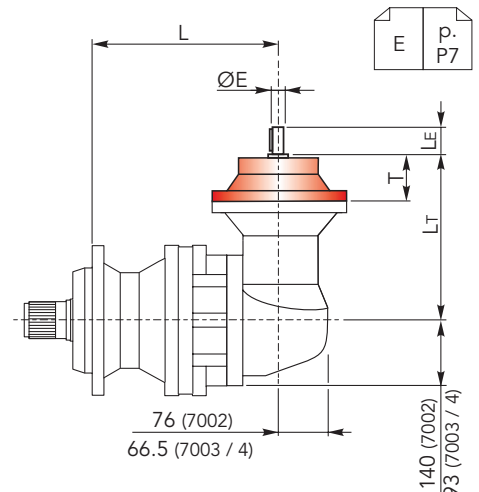



## DIMENSIONI CPC

## CPC DIMENSIONS

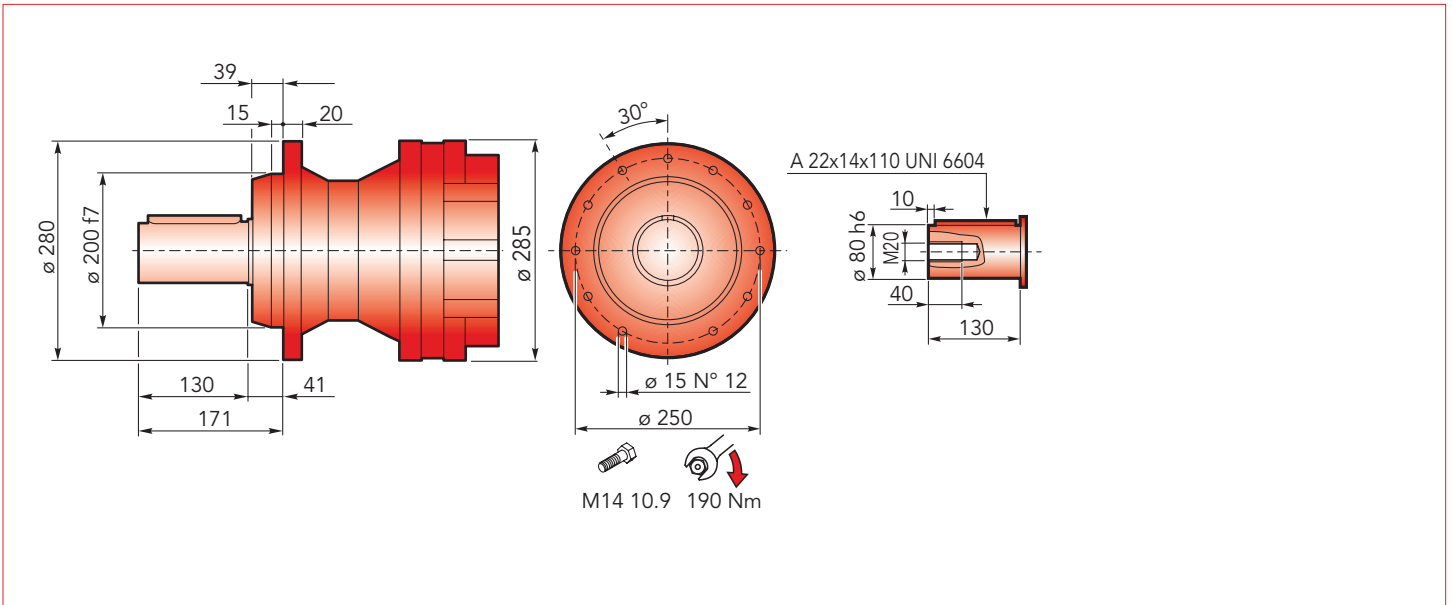

CHPL 7000 CPC - Flange motori IEC

CHPL 7000 CPC- IEC Motor flanges

CHPL	IEC 63			IEC 71			IEC 80			IEC 90			IEC 100		
	Lp	P	ØD	Lp	P	ØD	Lp	P	ØD	Lp	P	ØD	Lp	P	ØD
7001	-	-	-	-	-	-	-	-	-	-	-	-	-	-	-
7002	345.5	-	-	345.5	-	-	365.5	-	-	365.5	-	-	375.5	-	-
7003	393.5	36	140	393.5	36	160	413.5	56	200	413.5	56	200	423.5	66	250
7004	441.5	-	-	441.5	-	-	461.5	-	-	461.5	-	-	471.5	-	-

CHPL	IEC 112			IEC 132			IEC 160			IEC 180			IEC 200		
	Lp	P	ØD	Lp	P	ØD	Lp	P	ØD	Lp	P	ØD	Lp	P	ØD
7001	-	-	-	-	-	-	368	118	350	368	118	350	398	148	400
7002	375.5	-	-	409.5	-	-	448.5	-	350	448.5	139	350	-	-	-
7003	423.5	66	250	457.5	100	300	496.5	-	-	-	-	-	-	-	-
7004	471.5	-	-	505.5	-	-	-	-	-	-	-	-	-	-	-

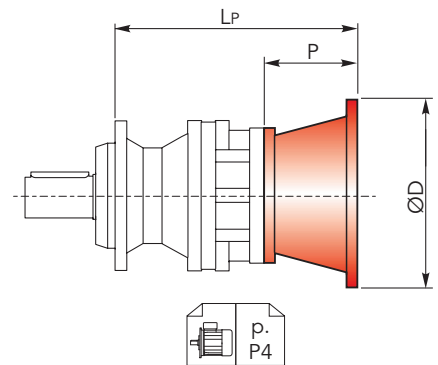

CHPL 7000 CPC - Alberi maschi entrata

CHPL 7000 CPC - Male input shafts

CHPL	CM42				CM65				CP65			
	Lt	T	Le	ØE	Lt	T	Le	ØE	Lt	T	Le	ØE
7001	-	-	-	-	371.5	-	-	-	403	-	-	-
7002	402.5	-	-	-	444.5	121.5	105	65 h6	476	153	105	65 h6
7003	450.5	93	82	42 h6	-	-	-	-	-	-	-	-
7004	498.5	-	-	-	-	-	-	-	-	-	-	-

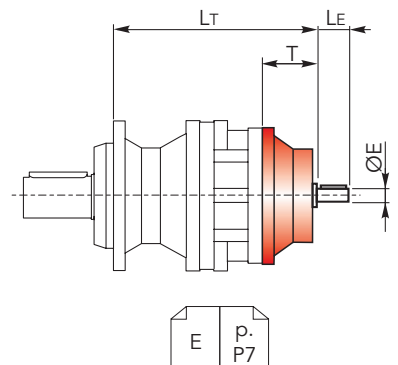





## DIMENSIONI CPC

## CPC DIMENSIONS

CHPL 7000 CPC - Riduttore a vite senza fine CHM in entrata

CHPL 7000 CPC - CHM input worm gearboxes

CHPL	CHM 50					CHM 63				
	Lv	I	H	M	N	Lv	I	H	M	N
7001	-					-				
7002	435					444.5				
7003	483	50	110	60	80	492.5	63	135	72	95
7004	531					540.5				

CHPL	CHM 75					CHM 90					CHM 110					
	Lv	I	H	M	N	Lv	I	H	M	N	Lv	I	H	M	N	
7001	-					-					388					
7002	423.5					433.5					461	110	237.5	127.5	160	
7003	471.5	75	161	86	112.5	481.5	90	193	103	129.5						
7004	519.5					529.5										

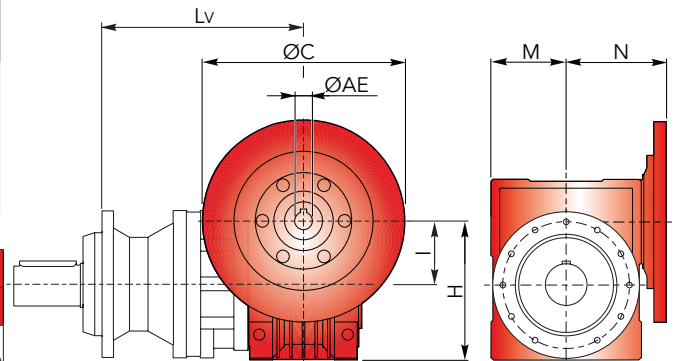

CHPL/CHPLB 7000

CHPLB 7000 CPC - Flange motori IEC

CHPLB 7000 CPC - IEC Motor flanges

CHPLB	IEC 63				IEC 71				IEC 80				IEC 90			
	L	Lp	P	ØD	L	Lp	P	ØD	L	Lp	P	ØD	L	Lp	P	ØD
7002	338	276			338	276			338	296			338	296		
7003	384.5		36	140	384.5		36	160	384.5		56	200	384.5		56	200
7004	432.5	196			432.5	196			432.5	216			432.5	216		

CHPLB	IEC 100				IEC 112				IEC 132				IEC 160				IEC 180			
	L	Lp	P	ØD	L	Lp	P	ØD	L	Lp	P	ØD	L	Lp	P	ØD	L	Lp	P	ØD
7002	338	306			338	306			338	340			338	379	139	350	338	379	139	350
7003	384.5		66	250	384.5		66	250	384.5		100	300	384.5		299					
7004	432.5	226			432.5	226			432.5	260										

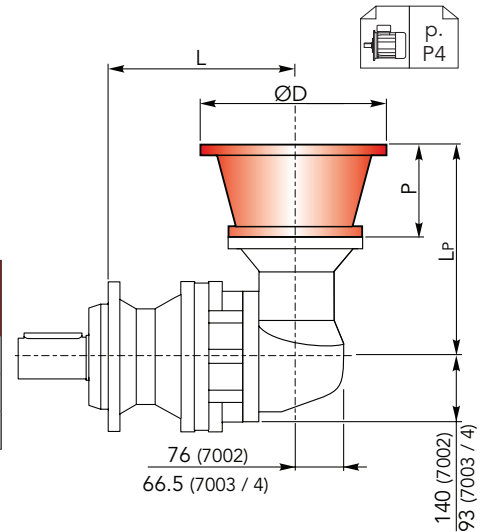

CHPLB 7000 CPC - Alberi maschi entrata

CHPL 7000 CPC - Male input shafts

CHPLB	CM42					CM65					CP65				
	L	Lt	T	Le	ØE	L	Lt	T	Le	ØE	L	Lt	T	Le	ØE
7002	338	333				338	377.5				338	409			
7003	384.5		93	82	42 h6	384.5		121.5	105	65 h6	384.5		153	105	65 h6
7004	432.5	253				432.5	297.5				432.5	329			

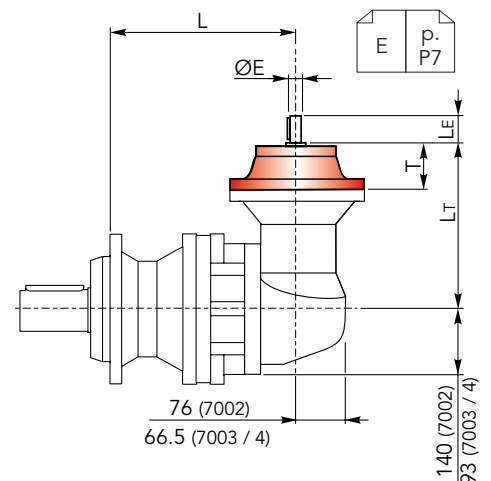



## DIMENSIONI CF

## CF DIMENSIONS

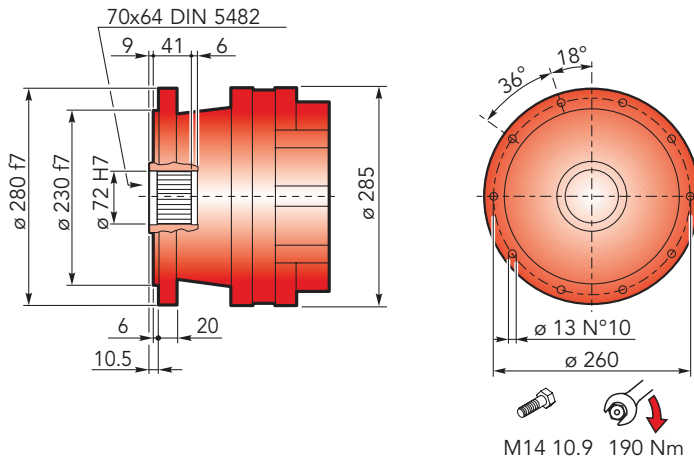

Accessori  
Accessories

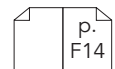

### CHPL 7000 CF - Flange motori IEC

### CHPL 7000 CF- IEC Motor flanges

CHPL	IEC 63			IEC 71			IEC 80			IEC 90			IEC 100		
	LP	P	ØD	LP	P	ØD	LP	P	ØD	LP	P	ØD	LP	P	ØD
7001	-			-			-			-			-		
7002	292			292			312			312			322		
7003	340	36	140	340	36	160	360	56	200	360	56	200	370	66	250
7004	388			388			408			408			418		

CHPL	IEC 112			IEC 132			IEC 160			IEC 180			IEC 200		
	LP	P	ØD	LP	P	ØD	LP	P	ØD	LP	P	ØD	LP	P	ØD
7001	-			-			314.5	118	350	314.5	118	350	344.5	148	400
7002	322			356			395		350	395	139	350	-		
7003	370	66	250	404	100	300	443			-			-		
7004	418			452			-			-			-		

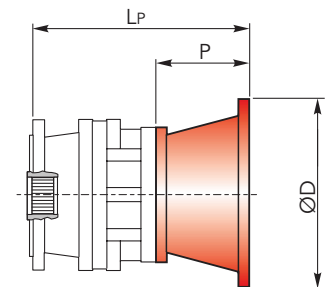

### CHPL 7000 CF - Alberi maschi entrata

### CHPL 7000 CF - Male input shafts

CHPL	CM42				CM65				CP65				
	LT	T	LE	ØE	LT	T	LE	ØE	LT	T	LE	ØE	
7001	-				318				349.5				
7002	349				391	121.5	105	65 h6	422.5	153	105	65 h6	
7003	397	93	82	42 h6	-			-			-		
7004	445				-			-			-		

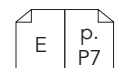
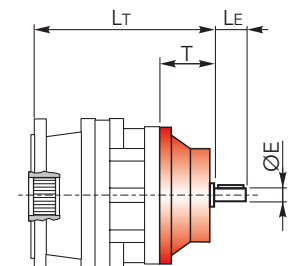



## DIMENSIONI CF

## CF DIMENSIONS

### CHPL 7000 CF - Riduttore a vite senza fine CHM in entrata

### CHPL 7000 CF - CHM input worm gearboxes

CHPL	CHM 50					CHM 63				
	Lv	I	H	M	N	Lv	I	H	M	N
7001	-					-				
7002	338					391				
7003	429.5	50	110	60	80	439	63	135	72	95
7004	477.5					487				

CHPL	CHM 75					CHM 90					CHM 110				
	Lv	I	H	M	N	Lv	I	H	M	N	Lv	I	H	M	N
7001	-					-					334.5	110	237.5	127.5	160
7002	370					380					407.5				
7003	418	75	161	86	112.5	428	90	193	103	129.5					
7004	466					476									

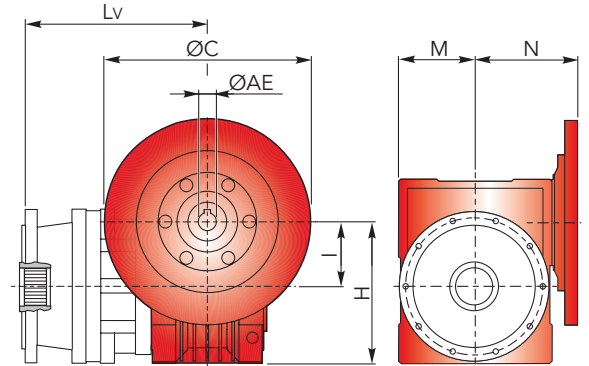

CHPL/CHPLB 7000

### CHPLB 7000 CF - Flange motori IEC

### CHPLB 7000 CF - IEC Motor flanges

CHPLB	IEC 63				IEC 71				IEC 80				IEC 90			
	L	Lp	P	ØD	L	Lp	P	ØD	L	Lp	P	ØD	L	Lp	P	ØD
7002	284.5	276			284.5	276			284.5	296			284.5	296		
7003	331	196	36	140	331	196	36	160	331	216	56	200	331	216	56	200
7004	379				379				379				379			

CHPLB	IEC 100				IEC 112				IEC 132				IEC 160				IEC 180			
	L	Lp	P	ØD	L	Lp	P	ØD	L	Lp	P	ØD	L	Lp	P	ØD	L	Lp	P	ØD
7002	284.5	306			284.5	306			284.5	340			284.5	379	139	350	284.5	379	139	350
7003	331	226	66	250	331	226	66	250	331	260	100	300	331	299	139	350				
7004	379				379				379				379							

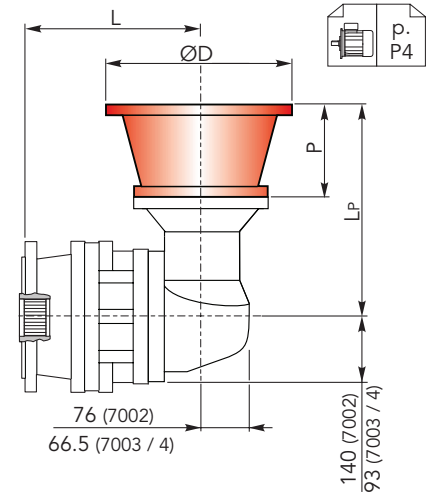

### CHPLB 7000 CF - Alberi maschi entrata

### CHPL 7000 CF - Male input shafts

CHPLB	CM42					CM65					CP65				
	L	Lt	T	Le	ØE	L	Lt	T	Le	ØE	L	Lt	T	Le	ØE
7002	284.5	333				284.5	377.5				284.5	409			
7003	331	253	93	82	42 h6	331	297.5	121.5	105	65 h6	331	329	153	105	65 h6
7004	379					379					379				

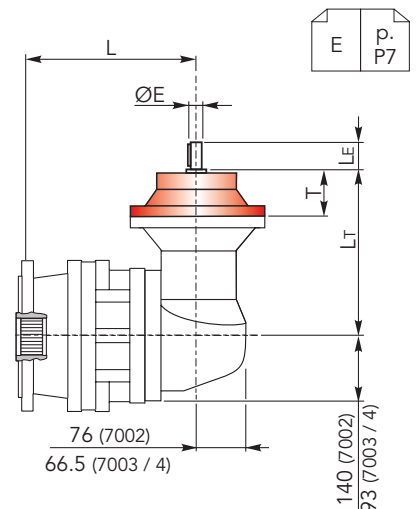



## DIMENSIONI CFS

## CFS DIMENSIONS

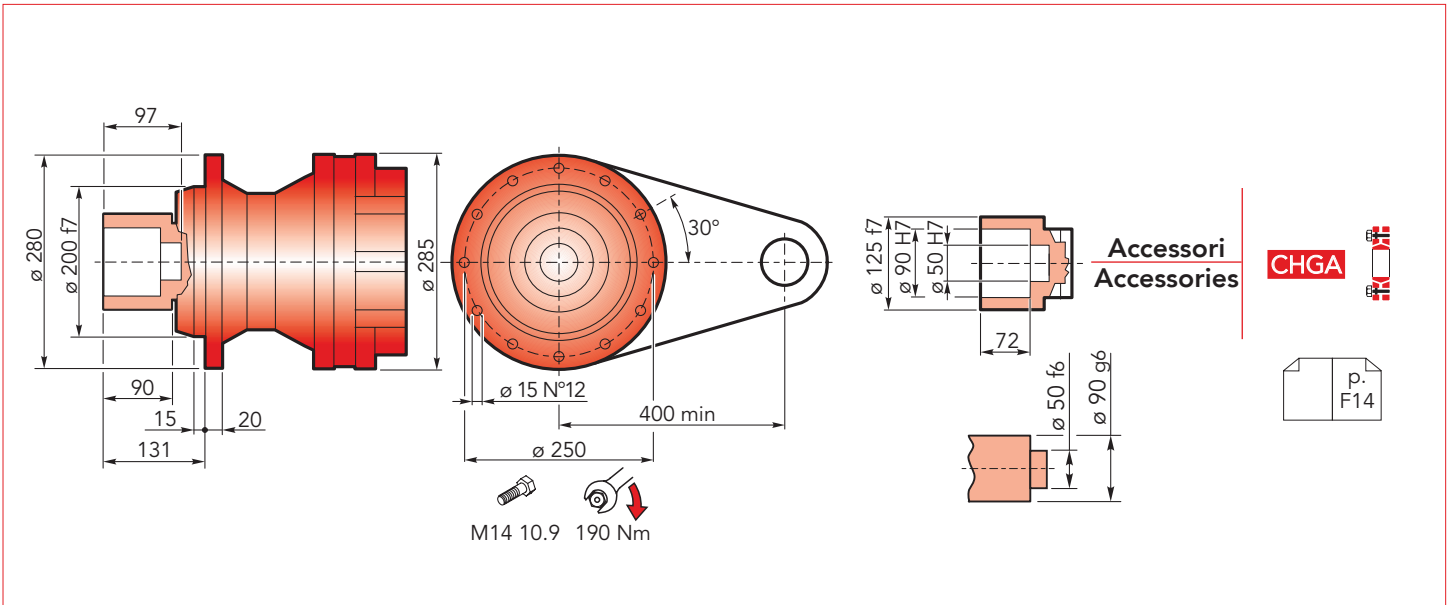

### CHPL 7000 CFS - Flange motori IEC

### CHPL 7000 CFS- IEC Motor flanges

CHPL	IEC 63			IEC 71			IEC 80			IEC 90			IEC 100		
	LP	P	ØD	LP	P	ØD	LP	P	ØD	LP	P	ØD	LP	P	ØD
7001	-			-			-			-			-		
7002	345.5			345.5			365.5			365.5			375.5		
7003	393.5	36	140	393.5	36	160	413.5	56	200	413.5	56	200	423.5	66	250
7004	441.5			441.5			461.5			461.5			471.5		

CHPL	IEC 112			IEC 132			IEC 160			IEC 180			IEC 200		
	LP	P	ØD	LP	P	ØD	LP	P	ØD	LP	P	ØD	LP	P	ØD
7001	-			-			368	118	350	368	118	350	398	148	400
7002	375.5			409.5			448.5			448.5	139	350	-		
7003	423.5	66	250	457.5	100	300	496.5			-			-		
7004	471.5			505.5			-			-			-		

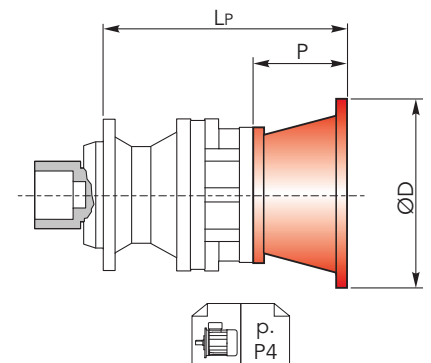

### CHPL 7000 CFS - Alberi maschi entrata

### CHPL 7000 CFS - Male input shafts

CHPL	CM42				CM65				CP65			
	LT	T	LE	ØE	LT	T	LE	ØE	LT	T	LE	ØE
7001	-				371.5				403			
7002	402.5				444.5	121.5	105	65 h6	476	153	105	65 h6
7003	450.5	93	82	42 h6	-			-				
7004	498.5				-			-				

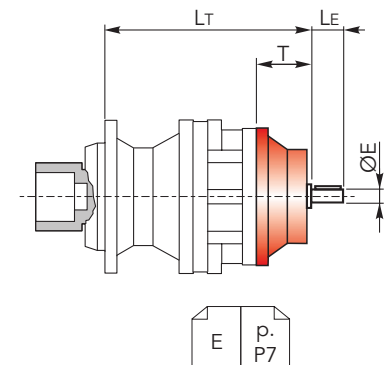



## DIMENSIONI CFS

## CFS DIMENSIONS

### CHPL 7000 CFS - Riduttore a vite senza fine CHM in entrata

### CHPL 7000 CFS - CHM input worm gearboxes

CHPL	CHM 50					CHM 63				
	Lv	I	H	M	N	Lv	I	H	M	N
7001	-					-				
7002	435					444.5				
7003	483	50	110	60	80	492.5	63	135	72	95
7004	531					540.5				

CHPL	CHM 75					CHM 90					CHM 110					
	Lv	I	H	M	N	Lv	I	H	M	N	Lv	I	H	M	N	
7001	-					-					388					
7002	423.5					433.5					461	110	237.5	127.5	160	
7003	471.5	75	161	86	112.5	481.5	90	193	103	129.5						
7004	519.5					529.5										

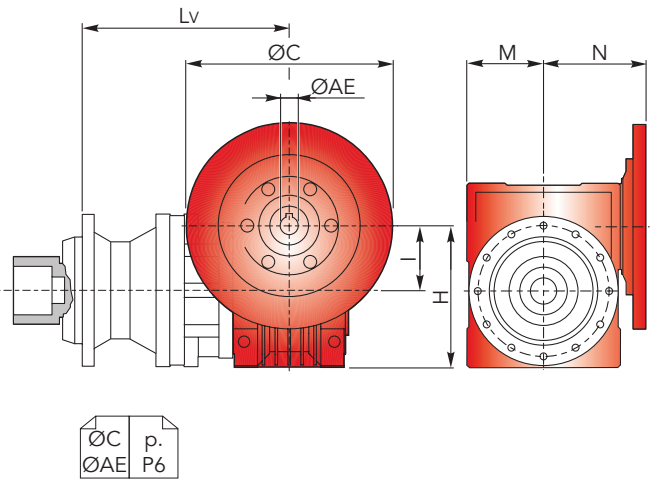

CHPL/CHPLB 7000

### CHPLB 7000 CFS - Flange motori IEC

### CHPLB 7000 CFS - IEC Motor flanges

CHPLB	IEC 63				IEC 71				IEC 80				IEC 90			
	L	Lp	P	ØD	L	Lp	P	ØD	L	Lp	P	ØD	L	Lp	P	ØD
7002	338	276			338	276			338	296			338	296		
7003	384.5	196	36	140	384.5	196	36	160	384.5	216	56	200	384.5	216	56	200
7004	432.5				432.5				432.5				432.5			

CHPLB	IEC 100				IEC 112				IEC 132				IEC 160				IEC 180			
	L	Lp	P	ØD	L	Lp	P	ØD	L	Lp	P	ØD	L	Lp	P	ØD	L	Lp	P	ØD
7002	338	306			338	306			338	340			338	379	139	350	338	379	139	350
7003	384.5	226	66	250	384.5	226	66	250	384.5	260	100	300	384.5	299						
7004	432.5				432.5				432.5											

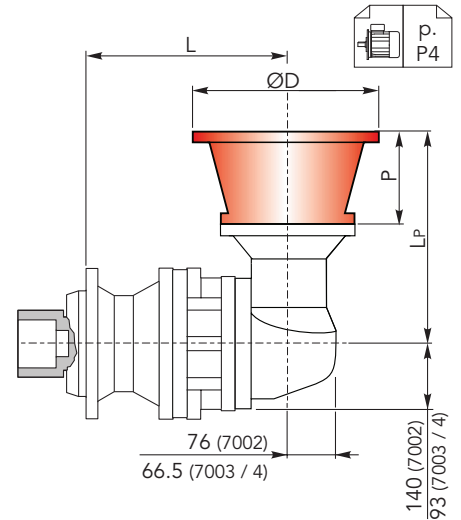

### CHPLB 7000 CFS - Alberi maschi entrata

### CHPL 7000 CFS - Male input shafts

CHPLB	CM42					CM65					CP65				
	L	Lt	T	Le	ØE	L	Lt	T	Le	ØE	L	Lt	T	Le	ØE
7002	338	333				338	377.5				338	409			
7003	384.5	253	93	82	42 h6	384.5	297.5	121.5	105	65 h6	384.5	329	153	105	65 h6
7004	432.5					432.5					432.5				

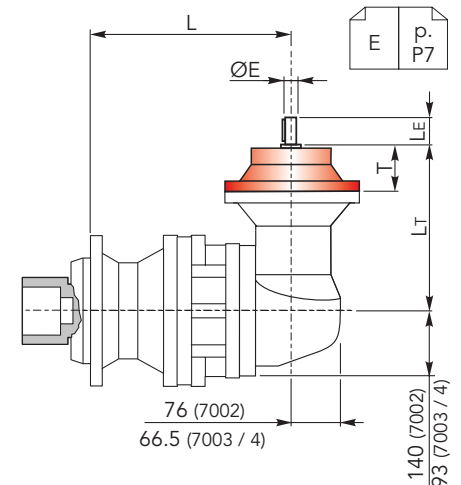



## DIMENSIONI CCPC

## CCPC DIMENSIONS

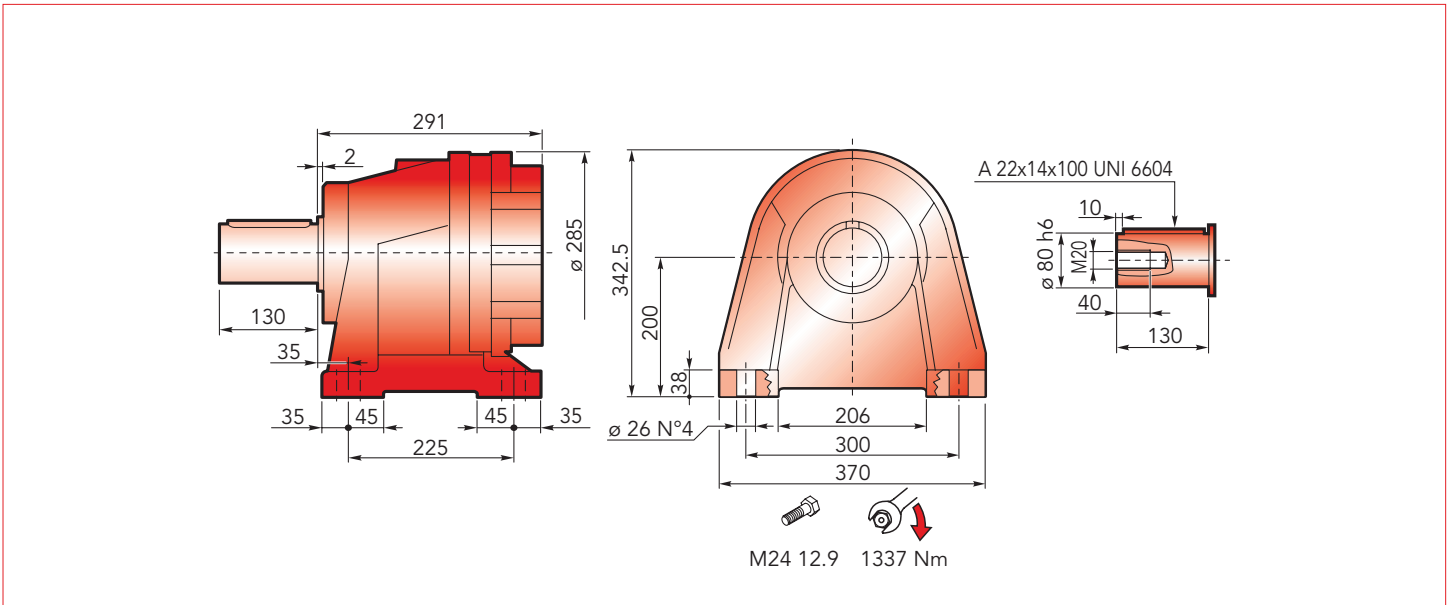

### CHPL 7000 CCPC - Flange motori IEC

### CHPL 7000 CCPC- IEC Motor flanges

CHPL	IEC 63			IEC 71			IEC 80			IEC 90			IEC 100		
	LP	P	ØD	LP	P	ØD	LP	P	ØD	LP	P	ØD	LP	P	ØD
7001	-			-			-			-			-		
7002	386.5			386.5			406.5			406.5			416.5		
7003	434.5	36	140	434.5	36	160	454.5	56	200	454.5	56	200	464.5	66	250
7004	482.5			482.5			502.5			502.5			512.5		

CHPL	IEC 112			IEC 132			IEC 160			IEC 180			IEC 200		
	LP	P	ØD	LP	P	ØD	LP	P	ØD	LP	P	ØD	LP	P	ØD
7001	-			-			409	118	350	409	118	350	439	148	400
7002	416.5			450.5			489.5			489.5	139	350	-		
7003	464.5	66	250	498.5	100	300	537.5			-			-		
7004	512.5			546.5			-			-			-		

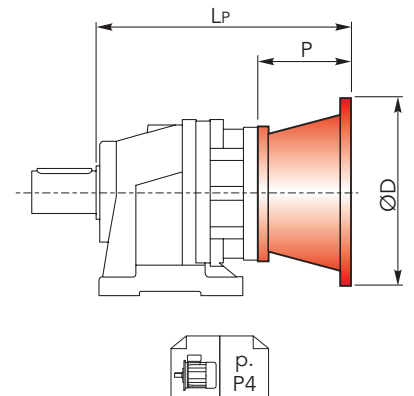

### CHPL 7000 CCPC - Alberi maschi entrata

### CHPL 7000 CCPC - Male input shafts

CHPL	CM42				CM65				CP65			
	LT	T	LE	ØE	LT	T	LE	ØE	LT	T	LE	ØE
7001	-				412.5				444			
7002	443.5				485.5	121.5	105	65 h6	517	153	105	65 h6
7003	491.5	93	82	42 h6	-			-				
7004	539.5				-			-				

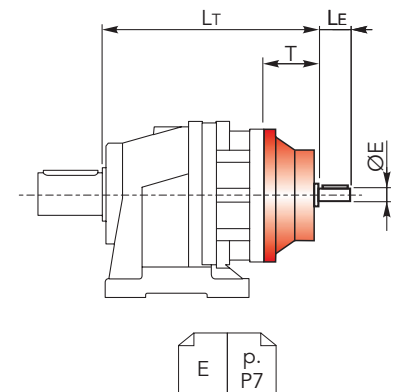



## DIMENSIONI CCPC

## CCPC DIMENSIONS

CHPL 7000 CCPC - Riduttore a vite senza fine CHM in entrata CHPL 7000 CCPC - CHM input worm gearboxes

CHPL	CHM 50					CHM 63				
	Lv	I	H	M	N	Lv	I	H	M	N
7001	-					-				
7002	476					485.5				
7003	524	50	110	60	80	533.5	63	135	72	95
7004	572					581.5				

CHPL	CHM 75					CHM 90					CHM 110				
	Lv	I	H	M	N	Lv	I	H	M	N	Lv	I	H	M	N
7001	-					-					429	110	237.5	127.5	160
7002	464.5					474.5					502				
7003	512.5	75	161	86	112.5	522.5	90	193	103	129.5					
7004	560.5					570.5									

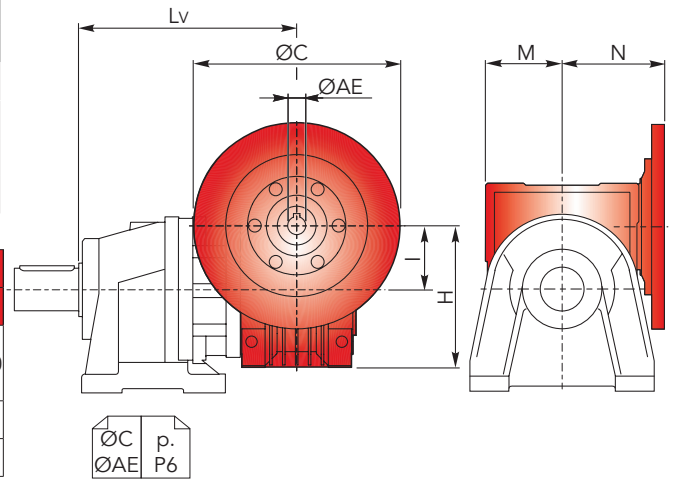

CHPL/CHPLB 7000

## CHPLB 7000 CCPC - Flange motori IEC

## CHPLB 7000 CCPC - IEC Motor flanges

CHPLB	IEC 63				IEC 71				IEC 80				IEC 90			
	L	Lp	P	ØD	L	Lp	P	ØD	L	Lp	P	ØD	L	Lp	P	ØD
7002	379	276			379	276			379	296			379	296		
7003	425.5	196	36	140	425.5	196	36	160	425.5	216	56	200	425.5	216	56	200
7004	473.5				473.5				473.5				473.5			

CHPLB	IEC 100				IEC 112				IEC 132				IEC 160				IEC 180			
	L	Lp	P	ØD	L	Lp	P	ØD	L	Lp	P	ØD	L	Lp	P	ØD	L	Lp	P	ØD
7002	379	306			379	306			379	340			379	379	139	350	379	379	139	350
7003	425.5	226	66	250	425.5	226	66	250	425.5	260	100	300	425.5	299						
7004	473.5				473.5				473.5											

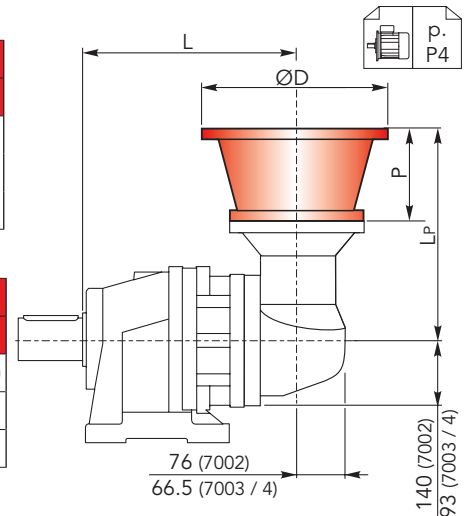

## CHPLB 7000 CCPC - Alberi maschi entrata

## CHPL 7000 CCPC - Male input shafts

CHPLB	CM42					CM65					CP65				
	L	Lt	T	Le	ØE	L	Lt	T	Le	ØE	L	Lt	T	Le	ØE
7002	379	333				379	377.5				379	409			
7003	425.5	253	93	82	42 h6	425.5	297.5	121.5	105	65 h6	425.5	329	153	105	65 h6
7004	473.5					473.5					473.5				

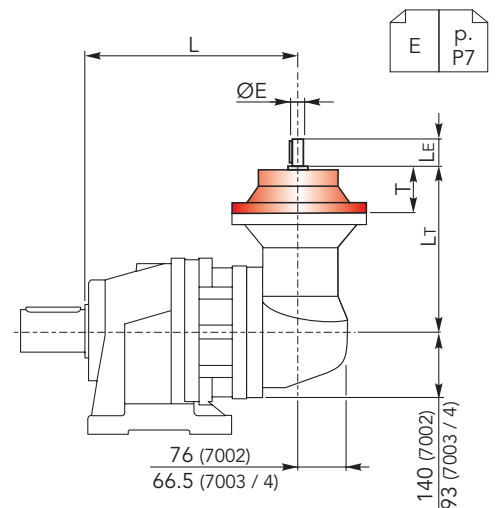



## ACCESSORI

## ACCESSORIES

### CHYZ Pignoni / Pinions

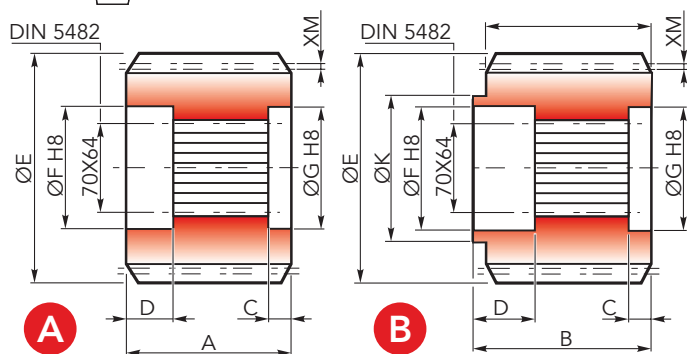

	Uscita / Output	M	Z	XM	A	B	C	D	E	F	G	K	Codice / Code
A	CPS	10	11	8.06	90	-	10	31	142.1	72	72	-	1071.267.042
	CPS	10	12	0	90	-	10	31	140	72	72	-	1071.166.042
	CPS	10	13	0	90	-	10	30	155	72	72	-	1071.201.042
B	CPS	10	11	8.06	90	99	18.5	31	142.1	72	72	84	1071.285.042

### CHFF Fondello di arresto / Stop bottom plate

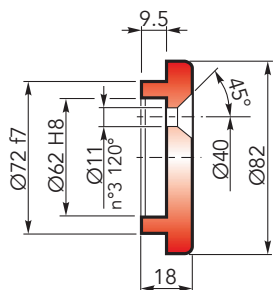

Codice / Code:  
1075.012.000

### CHBS Boccola scanalata / Splined bushing

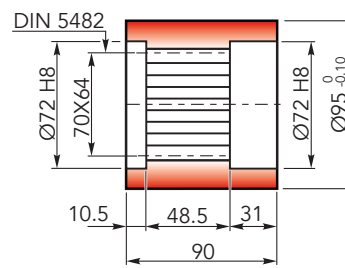

Codice / Code:  
5171.102.076

### CHKB Barra scanalata / Splined rod

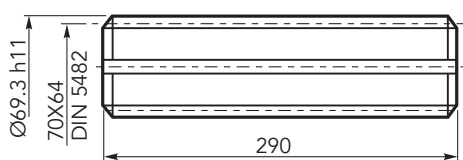

Codice / Code:  
3071.405.042

### CHGA Giunto di attrito / Shrink disc

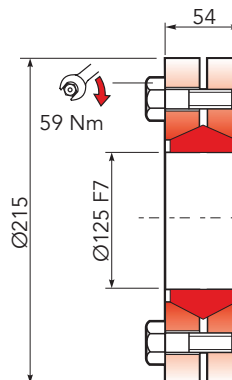

Coppia max: 13000 Nm<sup>(1)</sup>  
Max Torque: 13000 Nm<sup>(1)</sup>

Codice / Code:  
5109.125.000

(1): Coppia max indicata è valida solo con calettatori forniti da Chiaravalli S.p.A.

(1): The maximum torque indicated is valid only with shrink discs supplied by Chiaravalli S.p.A.

### CHFL Flangia / Flange

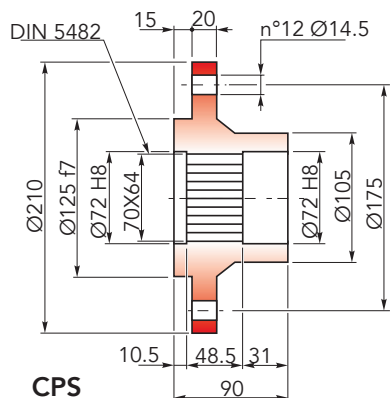

CPS  
Codice / Code:  
5171.108.098



## CARICHI RADIALI ( $F_r$ )

Nel diagramma seguente, sono indicati i carichi radiali  $F_r$  (N) applicabili sull'albero uscita in funzione della distanza di applicazione  $L$  rispetto alla battuta dell'albero.

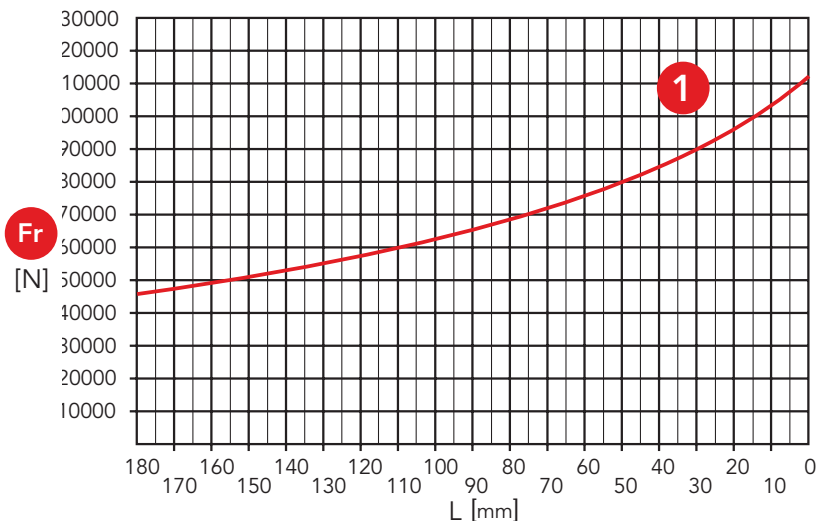

## RADIAL LOADS ( $F_r$ )

The hereunder table shows the allowable radial loads  $F_r$  (N) on the output shaft with reference to the distance  $L$ .

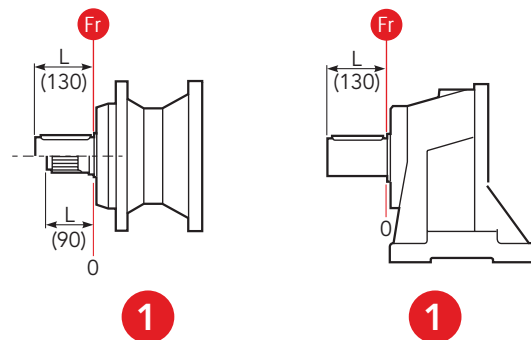

**1** Uscita / Output: CPS, CPC, CCPC

## CARICHI ASSIALI ( $F_a$ )

Nella tabella seguente sono indicati i carichi assiali  $F_a$  (N) applicabili sull'albero di uscita in funzione della direzione di applicazione del carico e della versione.

	<b>1</b>	
<b>F<sub>a</sub></b> [N]	40000	←
	60000	→

## AXIAL LOADS ( $F_a$ )

The hereunder table shows the allowable axial loads  $F_a$  (N) on the output shaft with reference to the load direction and the output type.

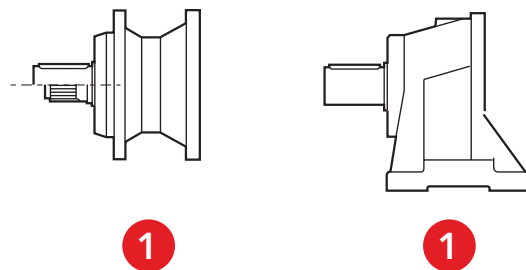





**1** Uscita / Output: CPS, CPC, CCPC



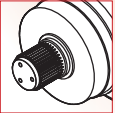
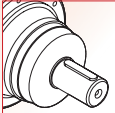
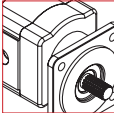
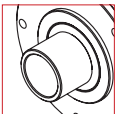
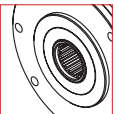
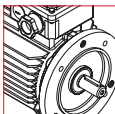
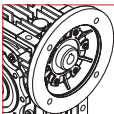

# CHPL/CHPLB 10000

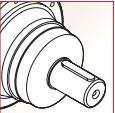
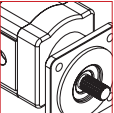
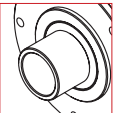
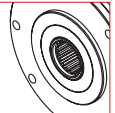
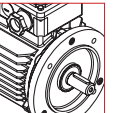
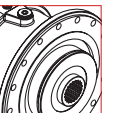

	<b>i</b>	<b>T<sub>2n</sub></b> (daNm)	<b>OUT</b>		<b>IN</b>	
<b>10001</b>	3.56 ÷ 8.67	322.1 ÷ 891.1	 Ø90	 80X74 DIN 5482	 Ø42 Ø65	 Hydraulic Motor
<b>10002</b>	13.4 ÷ 48.9	454.1 ÷ 891.1	 Ø100	 80X74 DIN 5482	 Electric Motor	 Worm gearboxes
<b>10003</b>	57.6 ÷ 330.3	454.1 ÷ 891.1				
<b>10004</b>	352.0 ÷ 2229.7	454.1 ÷ 891.1			 Brake	

	<b>i</b>	<b>T<sub>2n</sub></b> (daNm)	<b>OUT</b>		<b>IN</b>	
<b>10002</b>	12.3 ÷ 36.7	454.1 ÷ 891.1	 Ø90	 80X74 DIN 5482	 Ø42 Ø65	 Hydraulic Motor
<b>10003</b>	46.4 ÷ 266.4	454.1 ÷ 891.1	 Ø100	 80X74 DIN 5482	 Electric Motor	
<b>10004</b>	140.1 ÷ 969.0	454.1 ÷ 891.1			 Brake	

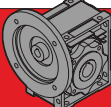

## DATI TECNICI

## TECHNICAL DATA

 CHPL	i	$T_{2n}$ ( $n_1=1400$ rpm)	$P_{1n}$ ( $n_1=1400$ rpm)	$P_t$	IEC	 CHM	 CM / CP
10001	3.56	891.1	367	40	160   180 200   225	CHM 110 CHM 130	CM65 CP65
	4.29	766.7	262				
	5.6	595.7	156				
	6.75	454.1	99				
	8.67	322.1	54				
10002	13.4	891.1	97	23	63   71 80   90 100   112 132   160	CHM 50 CHM 63 CHM 75 CHM 90 CHM 110 CHM 130	CM42 CM65 CP65
	16.2	766.7	69				
	18.4	891.1	71				
	22.1	766.7	51				
	25.7	766.7	44				
	28.9	595.7	30				
	33.6	595.7	26				
	40.5	454.1	16				
	48.9	454.1	14				
	57.6	891.1	23				
10003	62.9	891.1	21	15	63   71 80   90 100   112 132   160	CHM 50 CHM 63 CHM 75 CHM 90	CM42
	75.2	891.1	17				
	82.1	891.1	16				
	94.9	766.7	12				
	109.3	766.7	10				
	118.5	595.7	7.4				
	124	766.7	9.1				
	129.4	595.7	6.7				
	144	766.7	7.8				
	155.9	595.7	5.6				
	173.6	766.7	6.5				
	188.2	595.7	4.6				
	195.3	595.7	4.5				
	209.7	454.1	3.2				
	226.8	595.7	3.9				
	235.4	454.1	2.8				
	274.1	595.7	3.2				
330.3	454.1	2.0					
10004	352	891.1	3.7	11	63   71 80   90 100   112 132   160	CHM 50 CHM 63 CHM 75 CHM 90	CM42
	388.6	891.1	3.4				
	421.2	891.1	3.1				
	440.9	766.7	2.5				
	459.9	891.1	2.8				
	507.7	891.1	2.6				
	531.4	766.7	2.1				
	554.4	891.1	2.4				
	576.1	595.7	1.5				
	612	766.7	1.8				
	640.5	766.7	1.8				
	724.4	595.7	1.2				
	806.4	595.7	1.1				
	907.3	595.7	0.96				
	1008.9	766.7	1.1				
	1093.7	595.7	0.80				
	1270.1	595.7	0.69				
	1530.9	595.7	0.57				
1849.8	595.7	0.47					
2229.7	454.1	0.30					

 $n_{1max} = 2800$  rpm



## DATI TECNICI

## TECHNICAL DATA

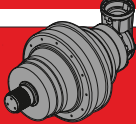
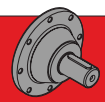
 CHPLB	i	T <sub>2n</sub> (n <sub>1</sub> =1400 rpm)	P <sub>1n</sub> (n <sub>1</sub> =1400 rpm)	P <sub>t</sub> [kW]	IEC		 CM / CP
		[daNm]	[kW]		(B5)		
10002	12.3	891.1	106	23	63 80 100 132 180	71 90 112 160	CM42 CM65 CP65
	14.8	766.7	76				
	19.3	595.7	45				
	23.3	454.1	29				
	30.5	595.7	29				
	36.7	454.1	18				
10003	46.4	891.1	28	15	63 80 100 132	71 90 112 160	CM42 CM65 CP65
	50.7	891.1	26				
	61.1	766.7	18				
	73.1	891.1	18				
	88.8	766.7	13				
	96.2	766.7	12				
	116.1	595.7	7.5				
	120.6	766.7	9.3				
	125.8	595.7	6.9				
	140	766.7	8.0				
	157.5	595.7	5.5				
	182.9	595.7	4.8				
	221	595.7	4.0				
	266.4	454.1	2.5				
10004	140.1	891.1	9.3	11	63 80 100 132	71 90 112 160	CM42 CM65 CP65
	168.9	891.1	7.7				
	184.4	766.7	6.1				
	203.5	766.7	5.5				
	230.9	891.1	5.7				
	265.9	766.7	4.2				
	278.4	766.7	4.0				
	301.8	891.1	4.3				
	320.6	766.7	3.5				
	350	766.7	3.2				
	379.5	595.7	2.3				
	418.9	595.7	2.1				
	457.4	595.7	1.9				
	510.4	595.7	1.7				
	551.9	595.7	1.6				
	665.3	595.7	1.3				
	803.9	595.7	1.1				
969	454.1	0.69					

n<sub>1max</sub> = 2800 rpm



## DIMENSIONI CMS

## CMS DIMENSIONS

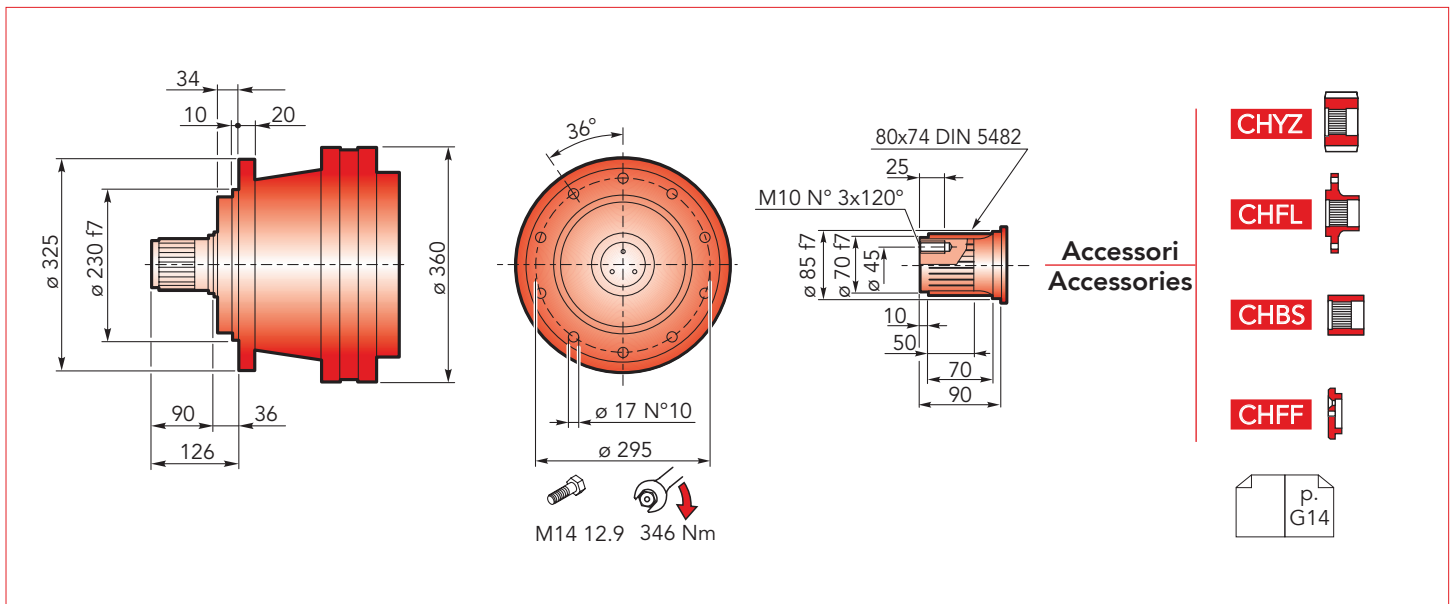

## CHPL 10000 CMS - Flange motori IEC

## CHPL 10000 CMS- IEC Motor flanges

CHPL	IEC 63			IEC 71			IEC 80			IEC 90			IEC 100		
	LP	P	ØD	LP	P	ØD	LP	P	ØD	LP	P	ØD	LP	P	ØD
10001	-			-			-			-			-		
10002	331.5			331.5			351.5			351.5			361.5		
10003	392.5	36	140	392.5	36	160	412.5	56	200	412.5	56	200	422.5	66	250
10004	440.5			440.5			460.5			460.5			470.5		

CHPL	IEC 112			IEC 132			IEC 160			IEC 180			IEC 200			IEC 225		
	LP	P	ØD	LP	P	ØD	LP	P	ØD	LP	P	ØD	LP	P	ØD	LP	P	ØD
10001	-			-			342	118	350	342	118	350	372	148	400	363	139	450
10002	361.5			395.5			434.5			434.5	139	350	-			-		
10003	422.5	66	250	456.5	100	300	495.5	139	350	-			-			-		
10004	470.5			504.5			543.5			-			-			-		

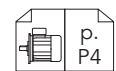
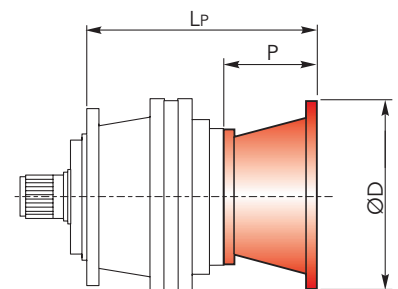

## CHPL 10000 CMS - Alberi maschi entrata

## CHPL 10000 CMS - Male input shafts

CHPL	CM42				CM65				CP65			
	LT	T	LE	ØE	LT	T	LE	ØE	LT	T	LE	ØE
10001	-				345.5				377			
10002	388.5				430.5	121.5	105	65 h6	462	153	105	65 h6
10003	449.5	93	82	42 h6	-			-				
10004	497.5				-			-				

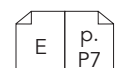
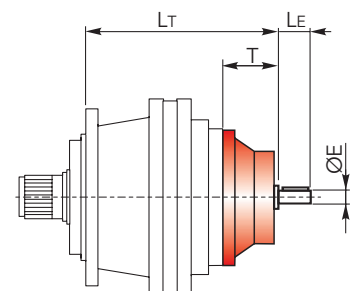



## DIMENSIONI CMS

## CMS DIMENSIONS

CHPL/CHPLB 10000

CHPL 10000 CMS - Riduttore a vite senza fine CHM in entrata

CHPL 10000 CMS - CHM input worm gearboxes

CHPL	CHM 50					CHM 63					CHM 75				
	Lv	I	H	M	N	Lv	I	H	M	N	Lv	I	H	M	N
10001	-					-					-				
10002	421					430.5					409.5				
10003	482	50	110	60	80	491.5	63	135	72	95	470.5	75	161	86	112.5
10004	530					539.5					518.5				

CHPL	CHM 90					CHM 110					CHM 130				
	Lv	I	H	M	N	Lv	I	H	M	N	Lv	I	H	M	N
10001	-					362	110	237.5	127.5	160	369	130	277.5	147.5	180
10002	419.5					447					454				
10003	480.5	90	193	103	129.5										
10004	528.5														

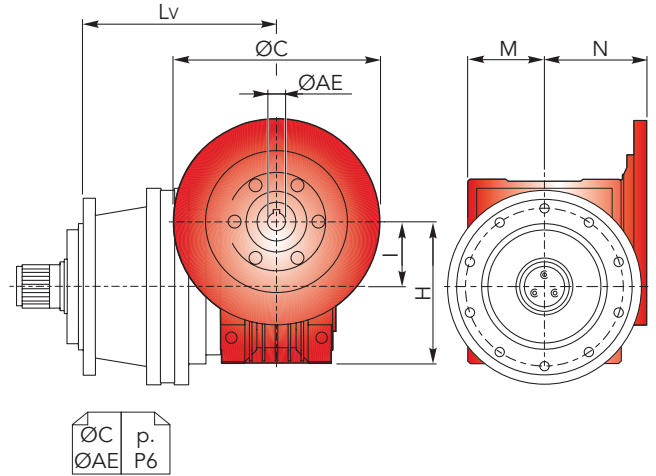

CHPLB 10000 CMS - Flange motori IEC

CHPLB 10000 CMS - IEC Motor flanges

CHPLB	IEC 63				IEC 71				IEC 80				IEC 90			
	L	Lp	P	ØD	L	Lp	P	ØD	L	Lp	P	ØD	L	Lp	P	ØD
10002	312				312				312				312			
10003	397	276	36	140	397	276	36	160	397	296	56	200	397	296	56	200
10004	431.5	196			431.5	196			431.5	216			431.5	216		

CHPLB	IEC 100				IEC 112				IEC 132				IEC 160				IEC 180				
	L	Lp	P	ØD	L	Lp	P	ØD	L	Lp	P	ØD	L	Lp	P	ØD	L	Lp	P	ØD	
10002	312				312				312				312				312				350
10003	397	306	66	250	397	306	66	250	397	340	100	300	397	379	139	350					
10004	431.5	226			431.5	226			431.5	260			431.5	299							

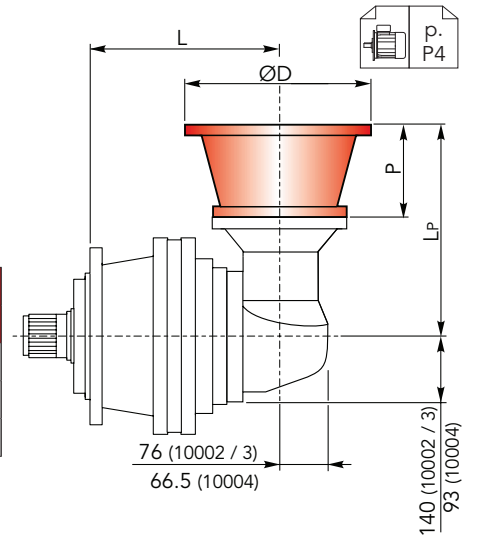

CHPLB 10000 CMS - Alberi maschi entrata

CHPL 10000 CMS - Male input shafts

CHPLB	CM42					CM65					CP65				
	L	Lt	T	Le	ØE	L	Lt	T	Le	ØE	L	Lt	T	Le	ØE
10002	312					312					312				
10003	397	333	93	82	42 h6	397	377.5	121.5	105	65 h6	397	409	153	105	65 h6
10004	431.5	253				431.5	297.5				431.5	329			

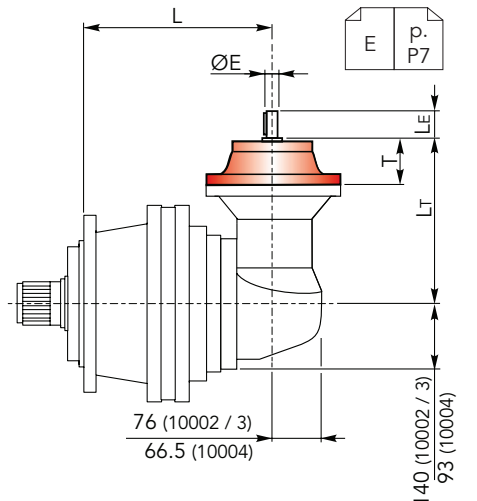



## DIMENSIONI CMC

## CMC DIMENSIONS

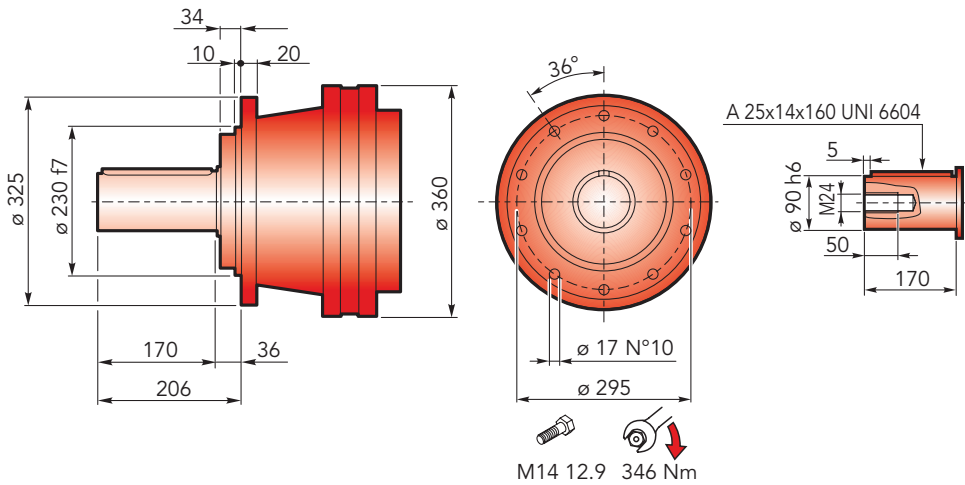

## CHPL 10000 CMC - Flange motori IEC

## CHPL 10000 CMC- IEC Motor flanges

CHPL	IEC 63			IEC 71			IEC 80			IEC 90			IEC 100		
	LP	P	ØD	LP	P	ØD	LP	P	ØD	LP	P	ØD	LP	P	ØD
10001	-			-			-			-			-		
10002	331.5			331.5			351.5			351.5			361.5		
10003	392.5	36	140	392.5	36	160	412.5	56	200	412.5	56	200	422.5	66	250
10004	440.5			440.5			460.5			460.5			470.5		

CHPL	IEC 112			IEC 132			IEC 160			IEC 180			IEC 200			IEC 225		
	LP	P	ØD	LP	P	ØD	LP	P	ØD	LP	P	ØD	LP	P	ØD	LP	P	ØD
10001	-			-			342	118	350	342	118	350	372	148	400	363	139	450
10002	361.5			395.5			434.5			434.5	139	350	-			-		
10003	422.5	66	250	456.5	100	300	495.5	139	350	-			-			-		
10004	470.5			504.5			543.5			-			-			-		

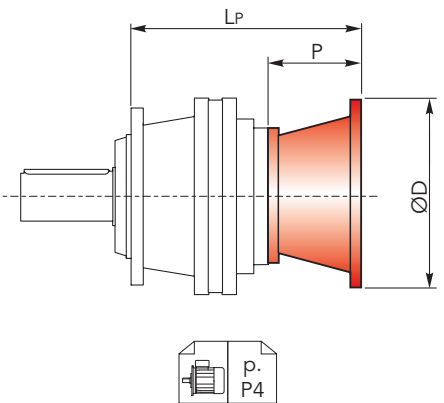

## CHPL 10000 CMC - Alberi maschi entrata

## CHPL 10000 CMC - Male input shafts

CHPL	CM42				CM65				CP65			
	LT	T	LE	ØE	LT	T	LE	ØE	LT	T	LE	ØE
10001	-				345.5				377			
10002	388.5				430.5	121.5	105	65 h6	462	153	105	65 h6
10003	449.5	93	82	42 h6	-				-			
10004	497.5				-				-			

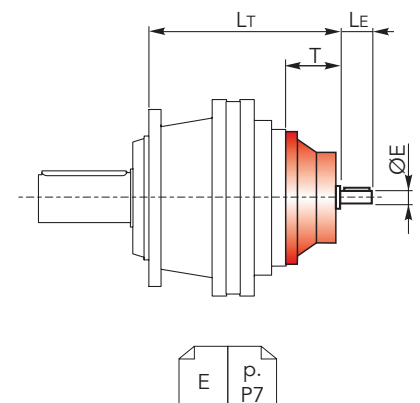





## DIMENSIONI CMC

## CMC DIMENSIONS

CHPL/CHPLB 10000

CHPL 10000 CMC - Riduttore a vite senza fine CHM in entrata CHPL 10000 CMC - CHM input worm gearboxes

CHPL	CHM 50					CHM 63					CHM 75				
	Lv	I	H	M	N	Lv	I	H	M	N	Lv	I	H	M	N
10001	-					-					-				
10002	421					430.5					409.5				
10003	482	50	110	60	80	491.5	63	135	72	95	470.5	75	161	86	112.5
10004	530					539.5					518.5				

CHPL	CHM 90					CHM 110					CHM 130				
	Lv	I	H	M	N	Lv	I	H	M	N	Lv	I	H	M	N
10001	-					362	110	237.5	127.5	160	369	130	277.5	147.5	180
10002	419.5					447					454				
10003	480.5	90	193	103	129.5	-					-				
10004	528.5					-					-				

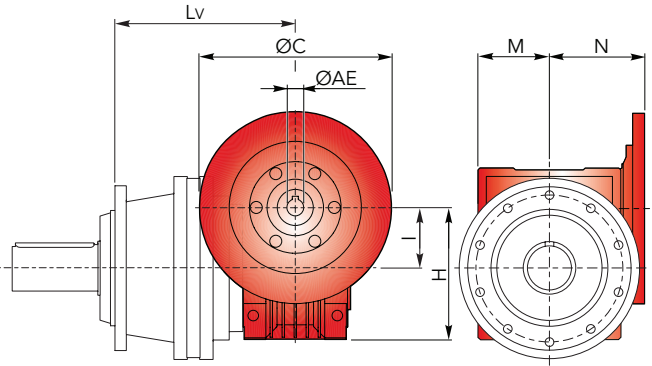

## CHPLB 10000 CMC - Flange motori IEC

## CHPLB 10000 CMC - IEC Motor flanges

CHPLB	IEC 63				IEC 71				IEC 80				IEC 90				
	L	Lp	P	ØD	L	Lp	P	ØD	L	Lp	P	ØD	L	Lp	P	ØD	
10002	312				312				312		296		312		296		200
10003	397	276	36	140	397	276	36	160	397	296	56	200	397	296	56	200	
10004	431.5	196			431.5	196			431.5	216			431.5	216			

CHPLB	IEC 100				IEC 112				IEC 132				IEC 160				IEC 180				
	L	Lp	P	ØD	L	Lp	P	ØD	L	Lp	P	ØD	L	Lp	P	ØD	L	Lp	P	ØD	
10002	312				312				312		340		312		379		312		379	139	350
10003	397	306	66	250	397	306	66	250	397	340	100	300	397	379	139	350	-				
10004	431.5	226			431.5	226			431.5	260			431.5	299			-				

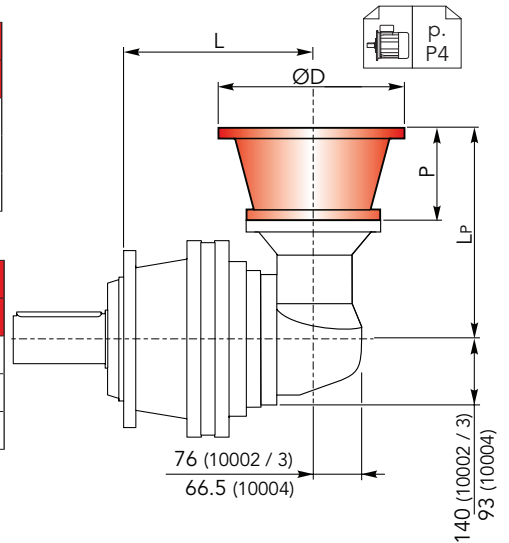

## CHPLB 10000 CMC - Alberi maschi entrata

## CHPL 10000 CMC - Male input shafts

CHPLB	CM42					CM65					CP65				
	L	Lt	T	Le	ØE	L	Lt	T	Le	ØE	L	Lt	T	Le	ØE
10002	312					312					312				
10003	397	333	93	82	42 h6	397	377.5	121.5	105	65 h6	397	409	153	105	65 h6
10004	431.5	253				431.5	297.5				431.5	329			

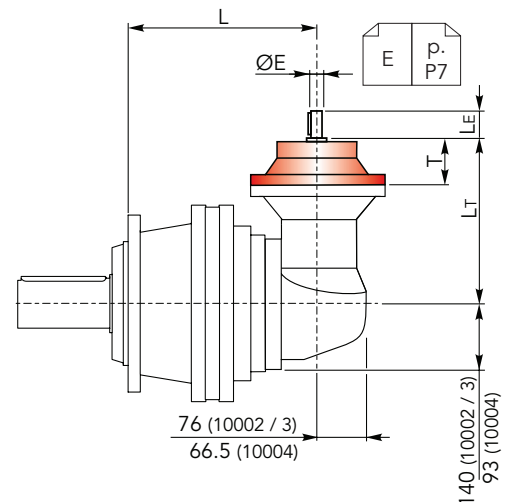



## DIMENSIONI CF

## CF DIMENSIONS

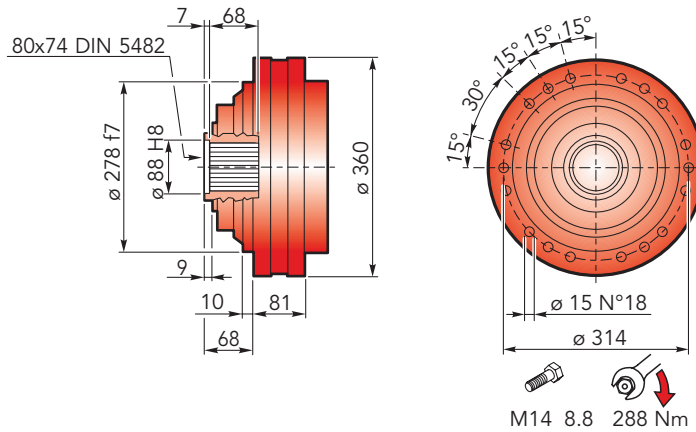

Accessori  
Accessories

CHKB



## CHPL 10000 CF - Flange motori IEC

## CHPL 10000 CF- IEC Motor flanges

CHPL	IEC 63			IEC 71			IEC 80			IEC 90			IEC 100		
	Lp	P	ØD	Lp	P	ØD	Lp	P	ØD	Lp	P	ØD	Lp	P	ØD
10001	-	-	-	-	-	-	-	-	-	-	-	-	-	-	-
10002	218.5	-	-	218.5	-	-	238.5	-	-	238.5	-	-	248.5	-	-
10003	279.5	36	140	279.5	36	160	299.5	56	200	299.5	56	200	309.5	66	250
10004	327.5	-	-	327.5	-	-	347.5	-	-	347.5	-	-	357.5	-	-

CHPL	IEC 112			IEC 132			IEC 160			IEC 180			IEC 200			IEC 225		
	Lp	P	ØD	Lp	P	ØD	Lp	P	ØD	Lp	P	ØD	Lp	P	ØD	Lp	P	ØD
10001	-	-	-	-	-	-	229	118	350	229	118	350	259	148	400	250	139	450
10002	248.5	-	-	282.5	-	-	321.5	-	-	321.5	139	350	-	-	-	-	-	-
10003	309.5	66	250	343.5	100	300	382.5	139	350	-	-	-	-	-	-	-	-	-
10004	357.5	-	-	391.5	-	-	430.5	-	-	-	-	-	-	-	-	-	-	-

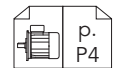
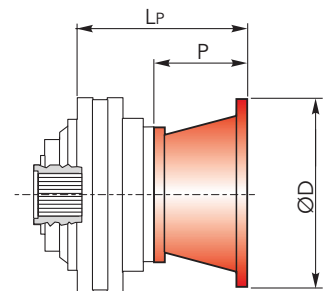

## CHPL 10000 CF - Alberi maschi entrata

## CHPL 10000 CF - Male input shafts

CHPL	CM42				CM65				CP65			
	Lt	T	Le	ØE	Lt	T	Le	ØE	Lt	T	Le	ØE
10001	-	-	-	-	232.5	-	-	-	264	-	-	-
10002	275.5	-	-	-	317.5	121.5	105	65 h6	349	153	105	65 h6
10003	336.5	93	82	42 h6	-	-	-	-	-	-	-	-
10004	384.5	-	-	-	-	-	-	-	-	-	-	-

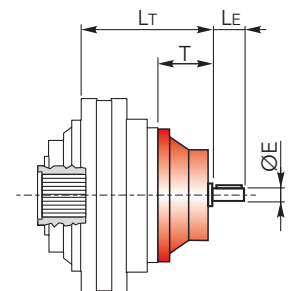



## DIMENSIONI CF

## CF DIMENSIONS

CHPL/CHPLB 10000

CHPL 10000 CF - Riduttore a vite senza fine CHM in entrata

CHPL 10000 CF - CHM input worm gearboxes

CHPL	CHM 50					CHM 63					CHM 75				
	Lv	I	H	M	N	Lv	I	H	M	N	Lv	I	H	M	N
10001	-					-					-				
10002	308					317.5					296.5				
10003	369	50	110	60	80	378.5	63	135	72	95	357.5	75	161	86	112.5
10004	417					426.5					405.5				

CHPL	CHM 90					CHM 110					CHM 130					
	Lv	I	H	M	N	Lv	I	H	M	N	Lv	I	H	M	N	
10001	-					249					256					
10002	306.5					334	110	237.5	127.5	160	341	130	277.5	147.5	180	
10003	367.5	90	193	103	129.5											
10004	415.5															

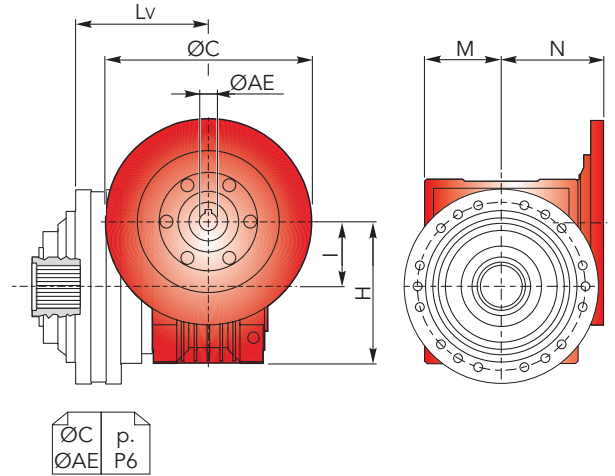

CHPLB 10000 CF - Flange motori IEC

CHPLB 10000 CF - IEC Motor flanges

CHPLB	IEC 63				IEC 71				IEC 80				IEC 90			
	L	Lp	P	ØD	L	Lp	P	ØD	L	Lp	P	ØD	L	Lp	P	ØD
10002	199				199				199				199			
10003	284	276	36	140	284	276	36	160	284	296	56	200	284	296	56	200
10004	318.5	196			318.5	196			318.5	216			318.5	216		

CHPLB	IEC 100				IEC 112				IEC 132				IEC 160				IEC 180			
	L	Lp	P	ØD	L	Lp	P	ØD	L	Lp	P	ØD	L	Lp	P	ØD	L	Lp	P	ØD
10002	199				199				199				199				199	379	139	350
10003	284	306	66	250	284	306	66	250	284	340	100	300	284	379	139	350				
10004	318.5	226			318.5	226			318.5	260			318.5	299						

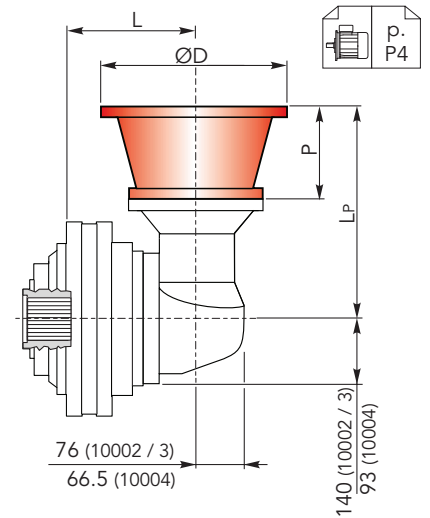

CHPLB 10000 CF - Alberi maschi entrata

CHPL 10000 CF - Male input shafts

CHPLB	CM42					CM65					CP65				
	L	Lt	T	Le	ØE	L	Lt	T	Le	ØE	L	Lt	T	Le	ØE
10002	199					199					199				
10003	284	333	93	82	42 h6	284	377.5	121.5	105	65 h6	284	409	153	105	65 h6
10004	318.5	253				318.5	297.5				318.5	329			

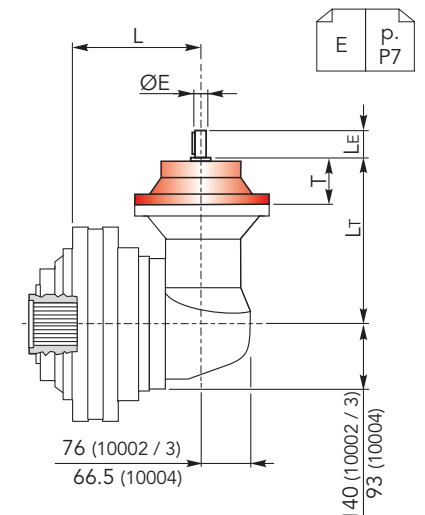



## DIMENSIONI CFS

## CFS DIMENSIONS

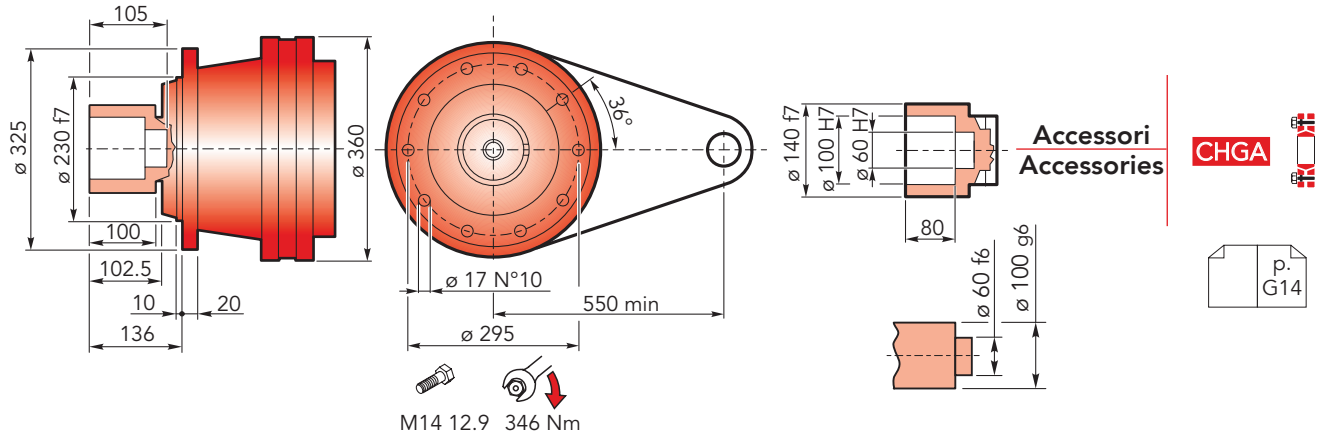

## CHPL 10000 CFS - Flange motori IEC

## CHPL 10000 CFS- IEC Motor flanges

CHPL	IEC 63			IEC 71			IEC 80			IEC 90			IEC 100		
	LP	P	ØD	LP	P	ØD	LP	P	ØD	LP	P	ØD	LP	P	ØD
10001	-			-			-			-			-		
10002	331.5			331.5			351.5			351.5			361.5		
10003	392.5	36	140	392.5	36	160	412.5	56	200	412.5	56	200	422.5	66	250
10004	440.5			440.5			460.5			460.5			470.5		

CHPL	IEC 112			IEC 132			IEC 160			IEC 180			IEC 200			IEC 225		
	LP	P	ØD	LP	P	ØD	LP	P	ØD	LP	P	ØD	LP	P	ØD	LP	P	ØD
10001	-			-			342	118	350	342	118	350	372	148	400	363	139	450
10002	361.5			395.5			434.5			434.5	139	350	-			-		
10003	422.5	66	250	456.5	100	300	495.5	139	350	-			-			-		
10004	470.5			504.5			543.5			-			-			-		

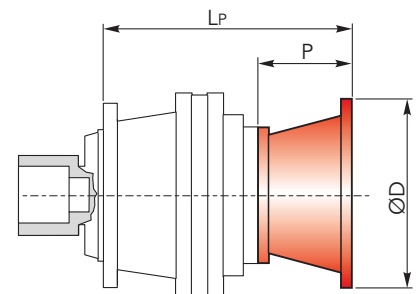

## CHPL 10000 CFS - Alberi maschi entrata

## CHPL 10000 CFS - Male input shafts

CHPL	CM42				CM65				CP65			
	LT	T	LE	ØE	LT	T	LE	ØE	LT	T	LE	ØE
10001	-				345.5				377			
10002	388.5				430.5	121.5	105	65 h6	462	153	105	65 h6
10003	449.5	93	82	42 h6	-				-			
10004	497.5				-				-			

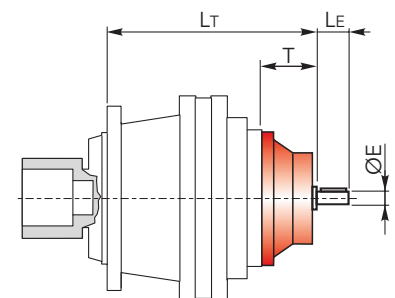



## DIMENSIONI CFS

## CFS DIMENSIONS

CHPL/CHPLB 10000

CHPL 10000 CFS - Riduttore a vite senza fine CHM in entrata CHPL 10000 CFS - CHM input worm gearboxes

CHPL	CHM 50					CHM 63					CHM 75				
	Lv	I	H	M	N	Lv	I	H	M	N	Lv	I	H	M	N
10001	-					-					-				
10002	421					430.5					409.5				
10003	482	50	110	60	80	491.5	63	135	72	95	470.5	75	161	86	112.5
10004	530					539.5					518.5				

CHPL	CHM 90					CHM 110					CHM 130					
	Lv	I	H	M	N	Lv	I	H	M	N	Lv	I	H	M	N	
10001	-					362					369					
10002	419.5					447	110	237.5	127.5	160	454	130	277.5	147.5	180	
10003	480.5	90	193	103	129.5	-					-					
10004	528.5					-					-					

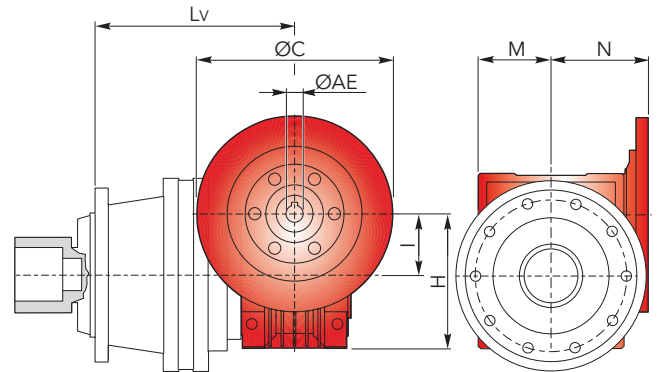

## CHPLB 10000 CFS - Flange motori IEC

## CHPLB 10000 CFS - IEC Motor flanges

CHPLB	IEC 63				IEC 71				IEC 80				IEC 90				
	L	Lp	P	ØD	L	Lp	P	ØD	L	Lp	P	ØD	L	Lp	P	ØD	
10002	312				312				312		296		312		296		200
10003	397	276	36	140	397	276	36	160	397		56	200	397	296	56	200	
10004	431.5	196			431.5	196			431.5	216			431.5	216			

CHPLB	IEC 100				IEC 112				IEC 132				IEC 160				IEC 180			
	L	Lp	P	ØD	L	Lp	P	ØD	L	Lp	P	ØD	L	Lp	P	ØD	L	Lp	P	ØD
10002	312				312				312				312				312	379	139	350
10003	397	306	66	250	397	306	66	250	397	340	100	300	397	379	139	350	-			
10004	431.5	226			431.5	226			431.5	260			431.5	299			-			

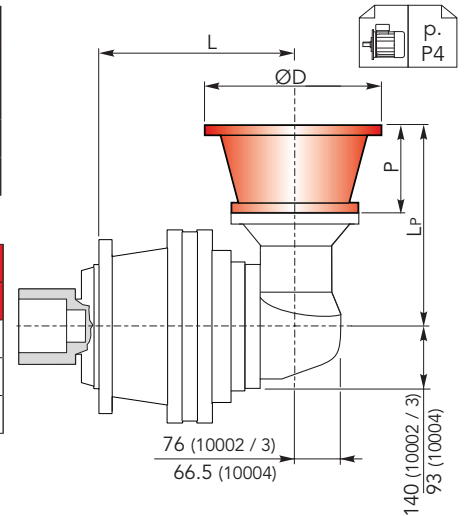

## CHPLB 10000 CFS - Alberi maschi entrata

## CHPL 10000 CFS - Male input shafts

CHPLB	CM42					CM65					CP65				
	L	Lt	T	Le	ØE	L	Lt	T	Le	ØE	L	Lt	T	Le	ØE
10002	312					312					312				
10003	397	333	93	82	42 h6	397	377.5	121.5	105	65 h6	397	409	153	105	65 h6
10004	431.5	253				431.5	297.5				431.5	329			

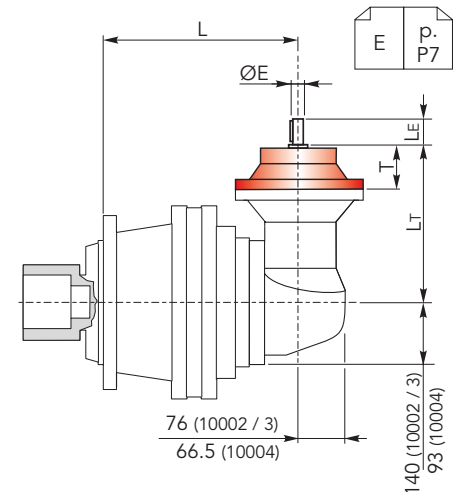



**DIMENSIONI CCPC**

**CCPC DIMENSIONS**

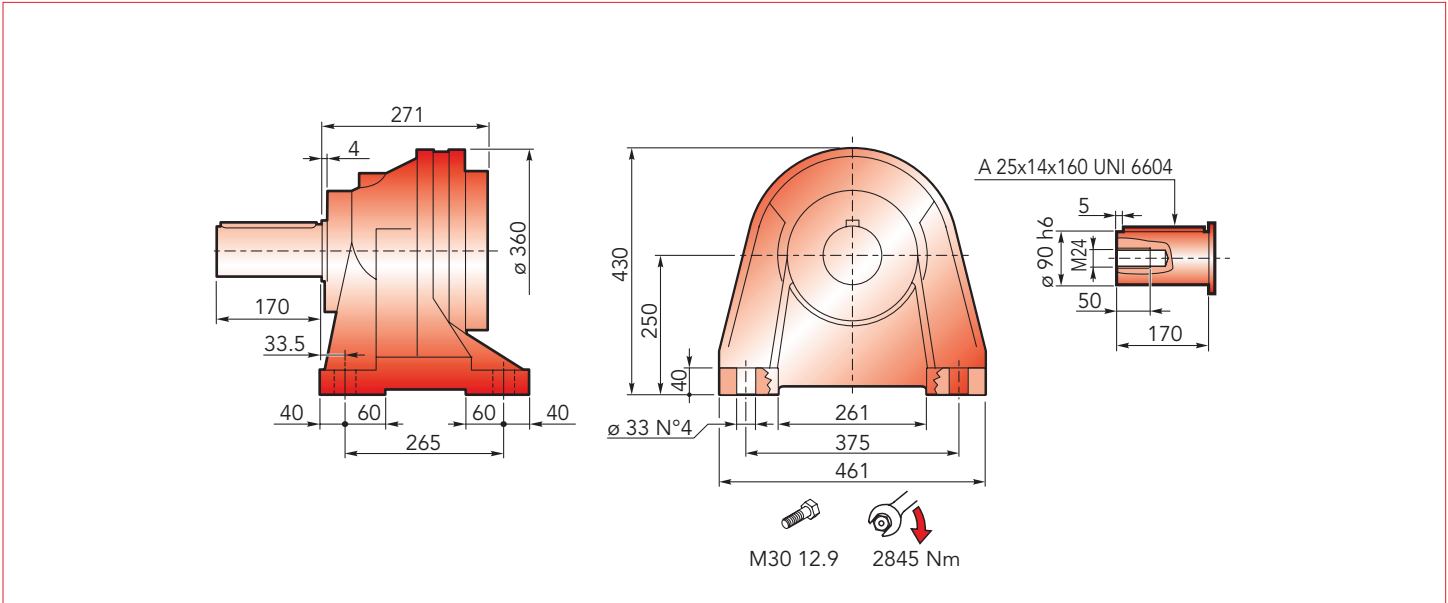

**CHPL 10000 CCPC - Flange motori IEC**

**CHPL 10000 CCPC- IEC Motor flanges**

CHPL	IEC 63			IEC 71			IEC 80			IEC 90			IEC 100		
	Lp	P	ØD	Lp	P	ØD	Lp	P	ØD	Lp	P	ØD	Lp	P	ØD
10001	-			-			-			-			-		
10002	378.5			378.5			398.5			398.5			408.5		
10003	439.5	36	140	439.5	36	160	459.5	56	200	459.5	56	200	469.5	66	250
10004	487.5			487.5			507.5			507.5			517.5		

CHPL	IEC 112			IEC 132			IEC 160			IEC 180			IEC 200			IEC 225		
	Lp	P	ØD	Lp	P	ØD	Lp	P	ØD	Lp	P	ØD	Lp	P	ØD	Lp	P	ØD
10001	-			-			389	118	350	389	118	350	419	148	400	410	139	450
10002	408.5			442.5			481.5			481.5	139	350	-			-		
10003	469.5	66	250	503.5	100	300	542.5	139	350	-			-			-		
10004	517.5			551.5			590.5			-			-			-		

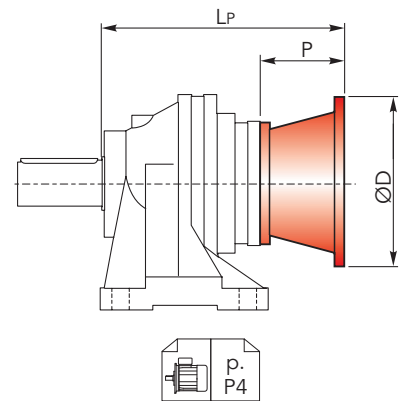

**CHPL 10000 CCPC - Alberi maschi entrata**

**CHPL 10000 CCPC - Male input shafts**

CHPL	CM42				CM65				CP65			
	Lt	T	Le	ØE	Lt	T	Le	ØE	Lt	T	Le	ØE
10001	-				392.5				424			
10002	435.5				477.5	121.5	105	65 h6	509	153	105	65 h6
10003	496.5	93	82	42 h6	-			-				
10004	544.5				-			-				

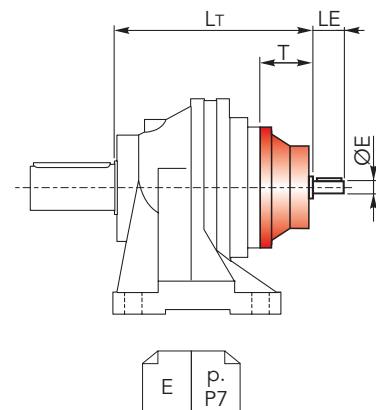



## DIMENSIONI CCPC

## CCPC DIMENSIONS

CHPL/CHPLB 10000

CHPL 10000 CCPC - Riduttore a vite senza fine CHM in entrata CHPL 10000 CCPC - CHM input worm gearboxes

CHPL	CHM 50					CHM 63					CHM 75				
	Lv	I	H	M	N	Lv	I	H	M	N	Lv	I	H	M	N
10001	-					-					-				
10002	468					477.5					456.5				
10003	529	50	110	60	80	538.5	63	135	72	95	517.5	75	161	86	112.5
10004	577					586.5					565.5				

CHPL	CHM 90					CHM 110					CHM 130					
	Lv	I	H	M	N	Lv	I	H	M	N	Lv	I	H	M	N	
10001	-					409					416					
10002	466.5					494	110	237.5	127.5	160	501	130	277.5	147.5	180	
10003	527.5	90	193	103	129.5	-					-					
10004	575.5					-					-					

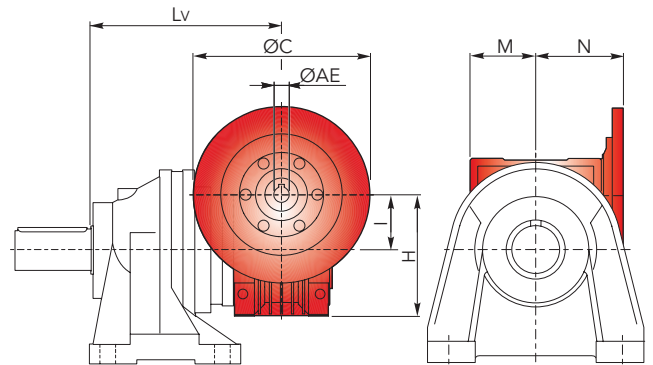

## CHPLB 10000 CCPC - Flange motori IEC

## CHPLB 10000 CCPC - IEC Motor flanges

CHPLB	IEC 63				IEC 71				IEC 80				IEC 90				
	L	Lp	P	ØD	L	Lp	P	ØD	L	Lp	P	ØD	L	Lp	P	ØD	
10002	359				359				359		296		359		296		200
10003	444	276	36	140	444	276	36	160	444		56	200	444	296	56	200	
10004	478.5	196			478.5	196			478.5	216			478.5	216			

CHPLB	IEC 100				IEC 112				IEC 132				IEC 160				IEC 180			
	L	Lp	P	ØD	L	Lp	P	ØD	L	Lp	P	ØD	L	Lp	P	ØD	L	Lp	P	ØD
10002	359				359				359	340			359	379			359	379	139	350
10003	444	306	66	250	444	306	66	250	444	340	100	300	444	379	139	350	-			
10004	478.5	226			478.5	226			478.5	260			478.5	299			-			

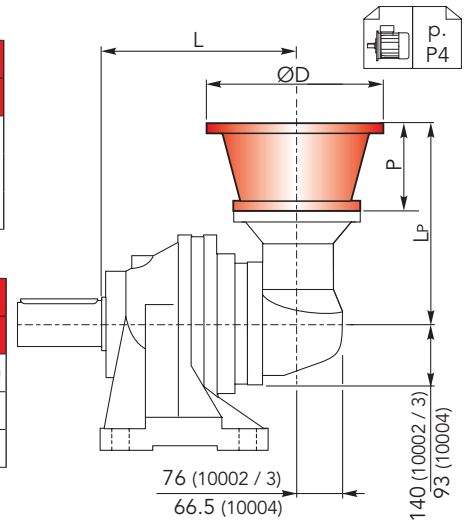

## CHPLB 10000 CCPC - Alberi maschi entrata

## CHPL 10000 CCPC - Male input shafts

CHPLB	CM42					CM65					CP65				
	L	Lt	T	Le	ØE	L	Lt	T	Le	ØE	L	Lt	T	Le	ØE
10002	359					359					359				
10003	444	333	93	82	42 h6	444	377.5	121.5	105	65 h6	444	409	153	105	65 h6
10004	478.5	253				478.5	297.5				478.5	329			

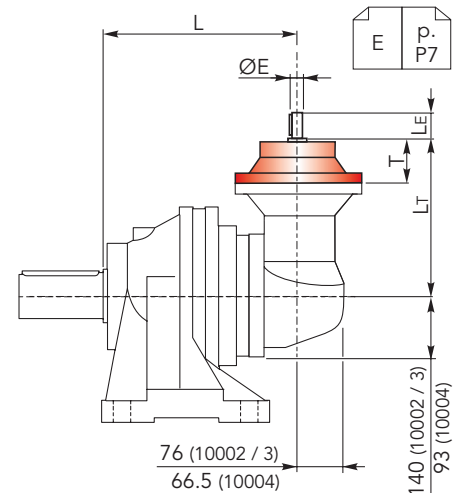



## ACCESSORI

## ACCESSORIES

CHYZ



## Pignoni / Pinions

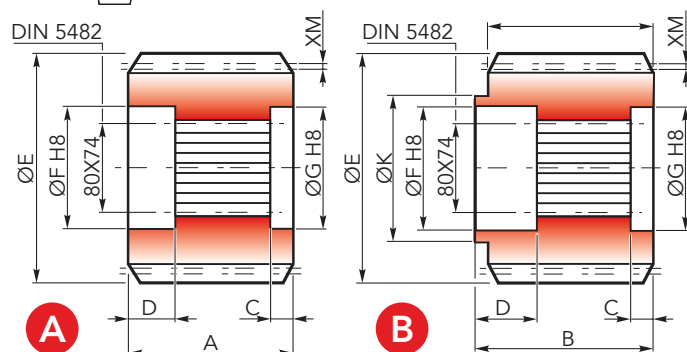

	Uscita / Output	M	Z	XM	A	B	C	D	E	F	G	K	Codice / Code
A	CMC	10	12	0	90	-	10	31	140	85	80	-	1071.236.042
	CMC	10	14	0	90	-	10	31	160	85	80	-	1071.238.042
B	CMC	12	14	3	90	115	25	31	194.5	85	80	130	1071.286.042

CHFF

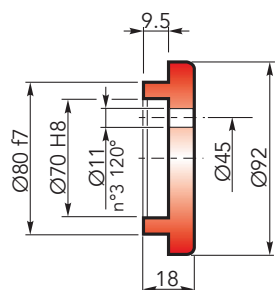

## Fondello di arresto / Stop bottom plate

Codice / Code:  
1075.030.000

CHBS

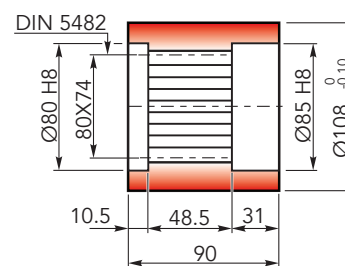

## Boccola scanalata / Splined bushing

Codice / Code:  
6171.103.076

CHKB

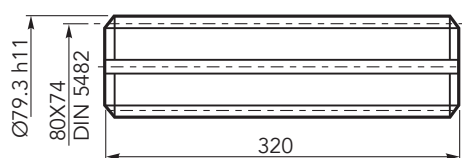

## Barra scanalata / Splined rod

Codice / Code:  
3071.406.042

CHGA

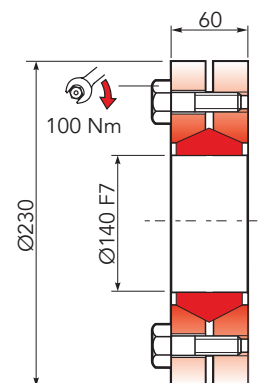

## Giunto di attrito / Shrink disc

Coppia max: 17600 Nm<sup>(1)</sup>  
Max Torque: 17600 Nm<sup>(1)</sup>Codice / Code:  
5109.140.000

(1): Coppia max indicata è valida solo con calettatori forniti da Chiaravalli S.p.A.

(1): The maximum torque indicated is valid only with shrink discs supplied by Chiaravalli S.p.A.

CHFL

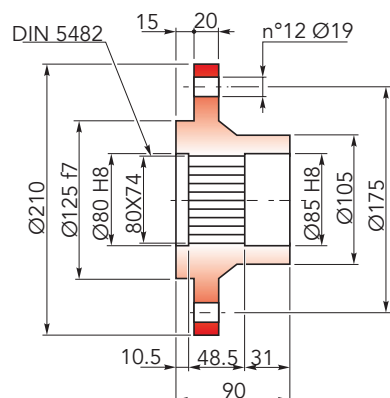

## Flangia / Flange

Codice / Code:  
6171.105.098





## CARICHI RADIALI ( $F_r$ )

## RADIAL LOADS ( $F_r$ )

Nel diagramma seguente, sono indicati i carichi radiali  $F_r$  (N) applicabili sull'albero uscita in funzione della distanza di applicazione  $L$  rispetto alla battuta dell'albero.

The hereunder table shows the allowable radial loads  $F_r$  (N) on the output shaft with reference to the distance  $L$ .

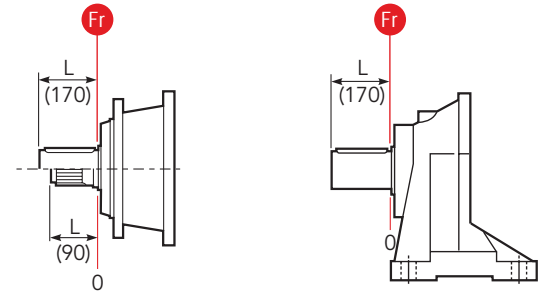
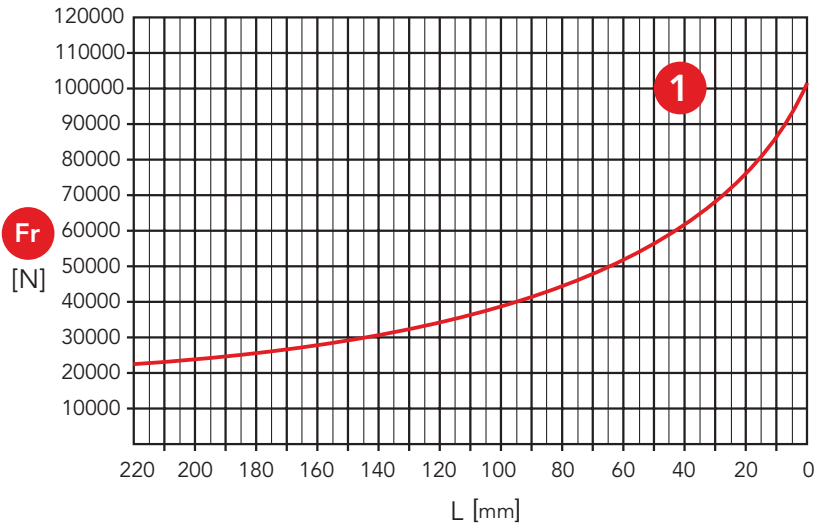

**1** Uscita / Output: CMS, CMC, CCPC

## CARICHI ASSIALI ( $F_a$ )

## AXIAL LOADS ( $F_a$ )

Nella tabella seguente sono indicati i carichi assiali  $F_a$  (N) applicabili sull'albero di uscita in funzione della direzione di applicazione del carico e della versione.

The hereunder table shows the allowable axial loads  $F_a$  (N) on the output shaft with reference to the load direction and the output type.

	<b>1</b>	
<b>F<sub>a</sub></b> [N]	40000	←
	65000	→

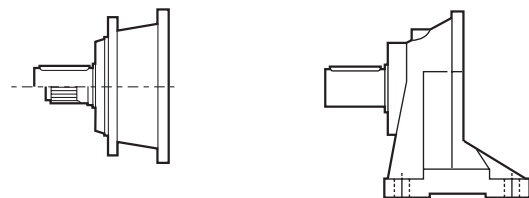



**1** Uscita / Output: CMS, CMC, CCPC





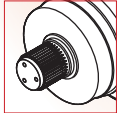
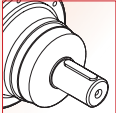
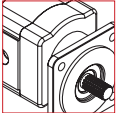
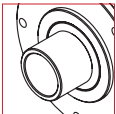
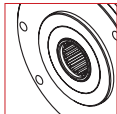
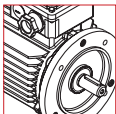
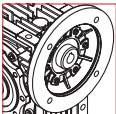

# CHPL/CHPLB 16000

	<b>i</b>	<b>T<sub>2n</sub></b> (daNm)	<b>OUT</b>		<b>IN</b>	
<b>16001</b>	3.56 ÷ 6.75	666.9 ÷ 1314.8	 Ø100	 80X74 100X94 DIN 5482	 Ø42 Ø65	 Hydraulic Motor
<b>16002</b>	13.4 ÷ 48.9	666.9 ÷ 1314.8	 Ø120	 80X74 DIN 5482	 Electric Motor	 Worm gearboxes
<b>16003</b>	57.6 ÷ 330.3	666.9 ÷ 1314.8				
<b>16004</b>	352.0 ÷ 2229.7	666.9 ÷ 1314.8			 Brake	

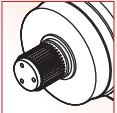
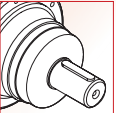
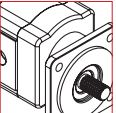
## CHPL

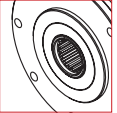
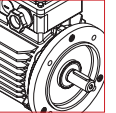
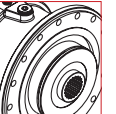
	<b>i</b>	<b>T<sub>2n</sub></b> (daNm)	<b>OUT</b>		<b>IN</b>	
<b>16002</b>	12.3 ÷ 36.7	666.9 ÷ 1314.8	 Ø100	 80X74 100X94 DIN 5482	 Ø42 Ø65	 Hydraulic Motor
<b>16003</b>	46.4 ÷ 266.4	666.9 ÷ 1314.8	 Ø120	 80X74 DIN 5482	 Electric Motor	
<b>16004</b>	140.1 ÷ 969.0	666.9 ÷ 1314.8			 Brake	

## CHPLB



## DATI TECNICI

## TECHNICAL DATA



CHPL	i	T <sub>2n</sub> (n <sub>1</sub> =1400 rpm) [daNm]	P <sub>1n</sub> (n <sub>1</sub> =1400 rpm) [kW]	P <sub>t</sub> [kW]	IEC		CHM	CM / CP
					(B5)			
16001	3.56	1314.8	541	40	160 200	180 225	CHM 110 CHM 130	CM65 CP65
	4.29	1146.7	392					
	5.6	876.9	230					
	6.75	666.9	145					
16002	13.4	1314.8	144	23	63 80 100 132 180	71 90 112 160	CHM 50 CHM 63 CHM 75 CHM 90 CHM 110 CHM 130	CM42 CM65 CP65
	16.2	1146.7	104					
	22.1	1146.7	76					
	28.9	876.9	44					
	33.6	876.9	38					
	40.5	666.9	24					
	48.9	666.9	20					
	57.6	1314.8	33					
	62.9	1314.8	31					
16003	75.2	1314.8	26	15	63 80 100 132	71 90 112 160	CHM 50 CHM 63 CHM 75 CHM 90	CM42
	82.1	1314.8	23					
	94.9	1146.7	18					
	109.3	1146.7	15					
	118.5	876.9	11					
	124	1146.7	14					
	129.4	876.9	10					
	144	876.9	8.9					
	155.9	876.9	8.2					
	188.2	876.9	6.8					
	195.3	876.9	6.6					
	209.7	666.9	4.7					
	226.8	876.9	5.7					
	235.4	666.9	4.2					
	274.1	876.9	4.7					
	330.3	666.9	3.0					
16004	352	1314.8	5.5	11	63 80 100 132	71 90 112 160	CHM 50 CHM 63 CHM 75 CHM 90	CM42
	388.6	1314.8	5.0					
	421.2	1314.8	4.6					
	440.9	1146.7	3.8					
	459.9	1314.8	4.2					
	507.7	1314.8	3.8					
	531.4	1146.7	3.2					
	554.4	1314.8	3.5					
	576.1	876.9	2.2					
	612	1146.7	2.7					
	640.5	1146.7	2.6					
	724.4	876.9	1.8					
	806.4	876.9	1.6					
	907.3	876.9	1.4					
	1008.9	1146.7	1.7					
	1093.7	876.9	1.2					
	1270.1	876.9	1.0					
1530.9	876.9	0.84						
1849.8	876.9	0.7						
2229.7	666.9	0.44						

n<sub>1max</sub> = 2800 rpm

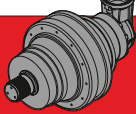

## DATI TECNICI

## TECHNICAL DATA

 CHPLB	i	T <sub>2n</sub> (n <sub>1</sub> =1400 rpm)	P <sub>1n</sub> (n <sub>1</sub> =1400 rpm)	P <sub>t</sub>	IEC	 CM / CP
		[daNm]	[kW]	[kW]	(B5)	
<b>16002</b>	12.3	1314.8	157	23	63   71 80   90 100   112 132   160 180	CM42 CM65 CP65
	14.8	1146.7	114			
	19.3	876.9	67			
	23.3	666.9	42			
	30.5	876.9	42			
	36.7	666.9	27			
<b>16003</b>	46.4	1314.8	42	15	63   71 80   90 100   112 132   160	CM42 CM65 CP65
	50.7	1314.8	38			
	61.1	1146.7	28			
	76.5	1146.7	22			
	88.8	1146.7	19			
	96.2	1146.7	17			
	116.1	876.9	11			
	120.6	1146.7	14			
	125.8	876.9	10			
	140	1146.7	12			
	157.5	876.9	8.2			
	182.9	876.9	7.0			
	221	876.9	5.8			
	266.4	666.9	3.7			
<b>16004</b>	140.1	1314.8	14	11	63   71 80   90 100   112 132   160	CM42 CM65 CP65
	168.9	1314.8	11			
	184.4	1146.7	9.1			
	203.5	1146.7	8.3			
	230.9	1146.7	7.3			
	240.9	876.9	5.3			
	290.4	1146.7	5.8			
	301.8	876.9	4.3			
	320.6	1146.7	5.2			
	347.5	876.9	3.7			
	379.5	876.9	3.4			
	418.9	876.9	3.1			
	457.4	876.9	2.8			
	510.4	876.9	2.5			
	551.9	876.9	2.3			
	665.3	876.9	1.9			
803.9	876.9	1.6				
969	666.9	1.0				

n<sub>1max</sub> = 2800 rpm

CHPL/CHPLB 16000



## DIMENSIONI CMS

## CMS DIMENSIONS

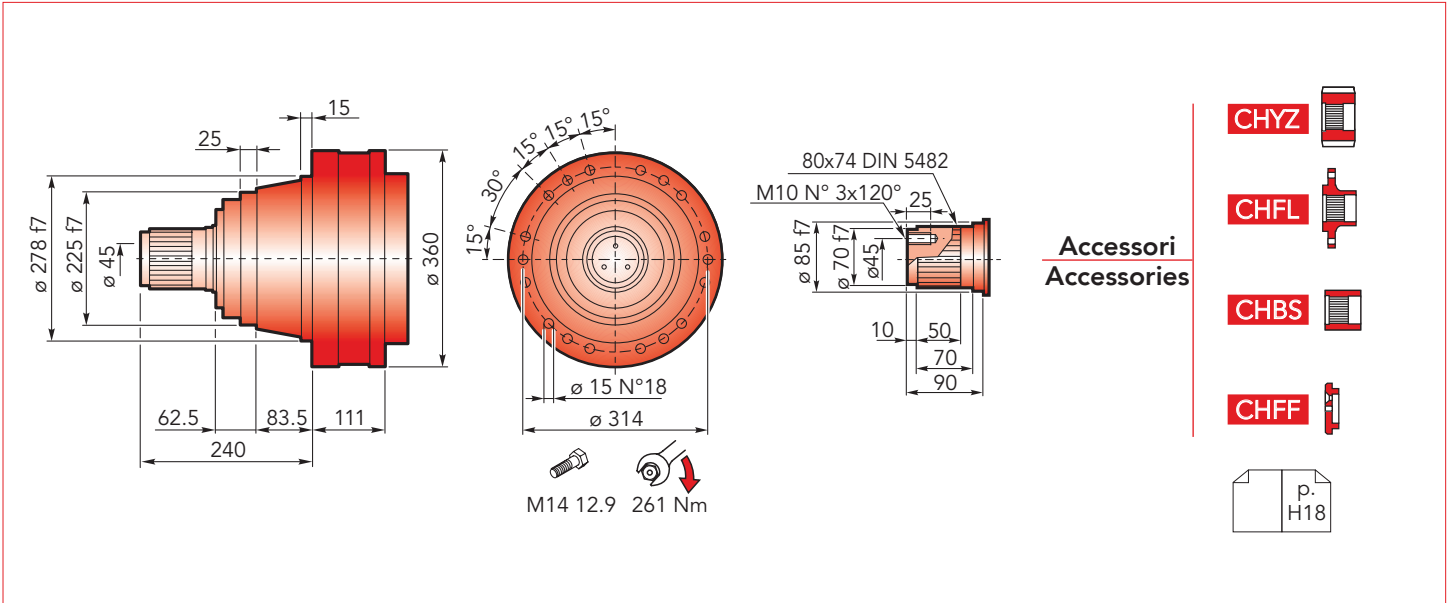

### CHPL 16000 CMS - Flange motori IEC

### CHPL 16000 CMS- IEC Motor flanges

CHPL	IEC 63			IEC 71			IEC 80			IEC 90			IEC 100		
	LP	P	ØD	LP	P	ØD	LP	P	ØD	LP	P	ØD	LP	P	ØD
16001	-			-			-			-			-		
16002	248.5			248.5			268.5			268.5			278.5		
16003	309.5	36	140	309.5	36	160	329.5	56	200	329.5	56	200	339.5	66	250
16004	357.5			357.5			377.5			377.5			387.5		

CHPL	IEC 112			IEC 132			IEC 160			IEC 180			IEC 200			IEC 225		
	LP	P	ØD	LP	P	ØD	LP	P	ØD	LP	P	ØD	LP	P	ØD	LP	P	ØD
16001	-			-			259	118	350	259	118	350	289	148	400	280	139	450
16002	278.5			312.5			351.5			351.5	139	350	-			-		
16003	339.5	66	250	373.5	100	300	412.5	139	350	-			-			-		
16004	387.5			421.5			-			-			-			-		

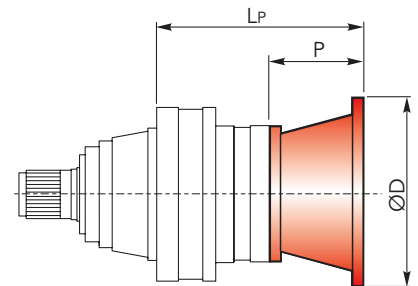

### CHPL 16000 CMS - Alberi maschi entrata

### CHPL 16000 CMS - Male input shafts

CHPL	CM42				CM65				CP65				
	LT	T	LE	ØE	LT	T	LE	ØE	LT	T	LE	ØE	
16001	-				262.5				294				
16002	305.5				347.5	121.5	105	65 h6	379	153	105	65 h6	
16003	366.5	93	82	42 h6	-			-			-		
16004	414.5				-			-			-		

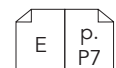
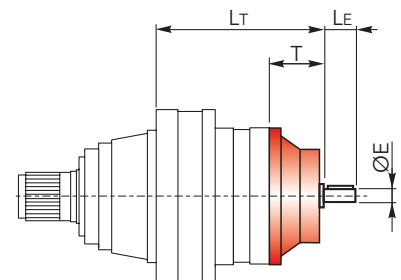



## DIMENSIONI CMS

## CMS DIMENSIONS

CHPL/CHPLB 16000

CHPL 16000 CMS - Riduttore a vite senza fine CHM in entrata

CHPL 16000 CMS - CHM input worm gearboxes

CHPL	CHM 50					CHM 63					CHM 75				
	Lv	I	H	M	N	Lv	I	H	M	N	Lv	I	H	M	N
16001	-					-					-				
16002	338					347.5					326.5				
16003	399	50	110	60	80	408.5	63	135	72	95	387.5	75	161	86	112.5
16004	447					456.5					435.5				

CHPL	CHM 90					CHM 110					CHM 130				
	Lv	I	H	M	N	Lv	I	H	M	N	Lv	I	H	M	N
16001	-					-					-				
16002	336.5					364	110	237.5	127.5	160	286	130	277.5	147.5	180
16003	397.5	90	193	103	129.5										
16004	445.5														

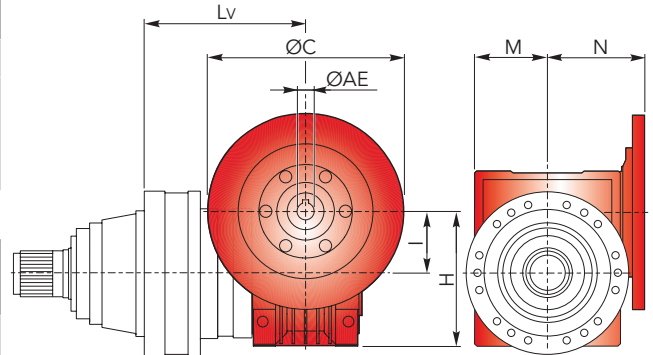

CHPLB 16000 CMS - Flange motori IEC

CHPLB 16000 CMS - IEC Motor flanges

CHPLB	IEC 63				IEC 71				IEC 80				IEC 90			
	L	Lp	P	ØD	L	Lp	P	ØD	L	Lp	P	ØD	L	Lp	P	ØD
16002	229				229	276	36	140	229	296	56	200	229	296	56	200
16003	314	276	36	140	314	276	36	160	314	296	56	200	314	296	56	200
16004	348.5	196			348.5	196			348.5	216			348.5	216		

CHPLB	IEC 100				IEC 112				IEC 132				IEC 160				IEC 180			
	L	Lp	P	ØD	L	Lp	P	ØD	L	Lp	P	ØD	L	Lp	P	ØD	L	Lp	P	ØD
16002	229				229	306	66	250	229	340	100	300	229	379	139	350	229	379	139	350
16003	314	306	66	250	314	306	66	250	314	340	100	300	314	379	139	350				
16004	348.5	226			348.5	226			348.5	260			348.5	299						

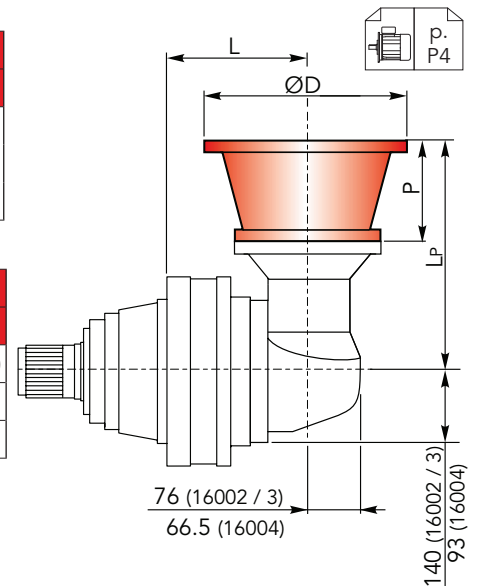

CHPLB 16000 CMS - Alberi maschi entrata

CHPL 16000 CMS - Male input shafts

CHPLB	CM42					CM65					CP65				
	L	Lt	T	Le	ØE	L	Lt	T	Le	ØE	L	Lt	T	Le	ØE
16002	229					229	377.5				229	409			
16003	314	333	93	82	42 h6	314	377.5	121.5	105	65 h6	314	409	153	105	65 h6
16004	348.5	253				348.5	297.5				348.5	329			

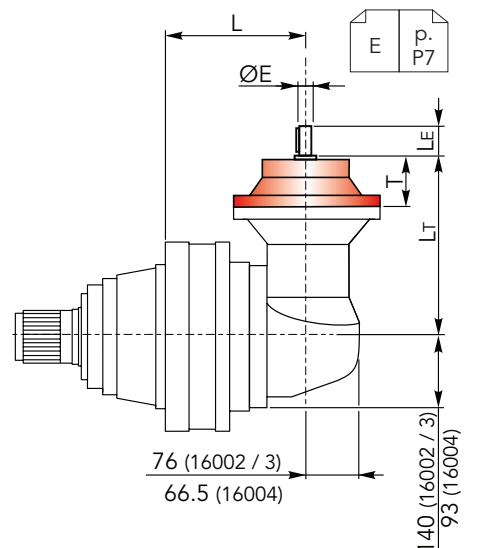



## DIMENSIONI CMC

## CMC DIMENSIONS

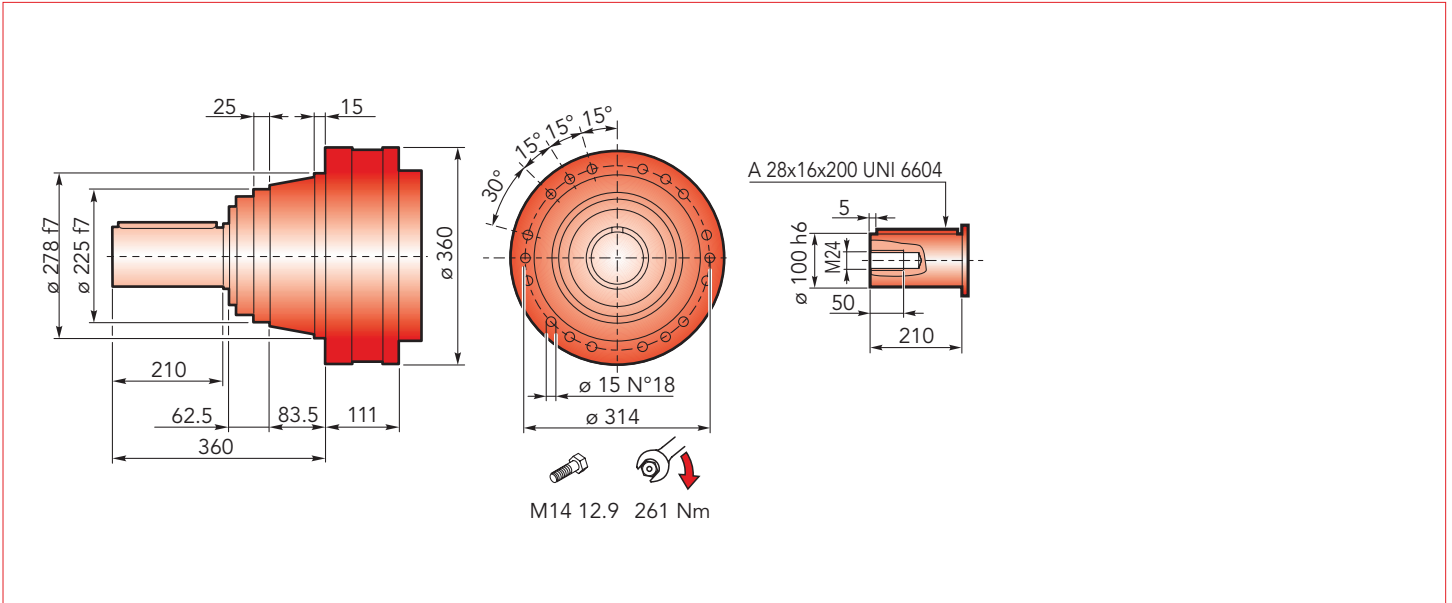

### CHPL 16000 CMC - Flange motori IEC

### CHPL 16000 CMC- IEC Motor flanges

CHPL	IEC 63			IEC 71			IEC 80			IEC 90			IEC 100		
	LP	P	ØD	LP	P	ØD	LP	P	ØD	LP	P	ØD	LP	P	ØD
16001	-			-			-			-			-		
16002	248.5			248.5			268.5			268.5			278.5		
16003	309.5	36	140	309.5	36	160	329.5	56	200	329.5	56	200	339.5	66	250
16004	357.5			357.5			377.5			377.5			387.5		

CHPL	IEC 112			IEC 132			IEC 160			IEC 180			IEC 200			IEC 225		
	LP	P	ØD	LP	P	ØD	LP	P	ØD	LP	P	ØD	LP	P	ØD	LP	P	ØD
16001	-			-			259	118	350	259	118	350	289	148	400	280	139	450
16002	278.5			312.5			351.5			351.5	139	350	-			-		
16003	339.5	66	250	373.5	100	300	412.5	139	350	-			-			-		
16004	387.5			421.5			-			-			-			-		

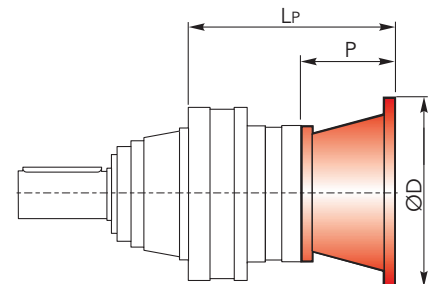

### CHPL 16000 CMC - Alberi maschi entrata

### CHPL 16000 CMC - Male input shafts

CHPL	CM42				CM65				CP65				
	LT	T	LE	ØE	LT	T	LE	ØE	LT	T	LE	ØE	
16001	-				262.5				294				
16002	305.5				347.5	121.5	105	65 h6	379	153	105	65 h6	
16003	366.5	93	82	42 h6	-			-			-		
16004	414.5				-			-			-		

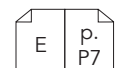
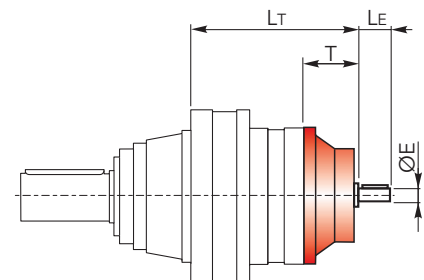





## DIMENSIONI CMC

## CMC DIMENSIONS

CHPL/CHPLB 16000

CHPL 16000 CMC - Riduttore a vite senza fine CHM in entrata CHPL 16000 CMC - CHM input worm gearboxes

CHPL	CHM 50					CHM 63					CHM 75				
	Lv	I	H	M	N	Lv	I	H	M	N	Lv	I	H	M	N
16001	-					-					-				
16002	338					347.5					326.5				
16003	399	50	110	60	80	408.5	63	135	72	95	387.5	75	161	86	112.5
16004	447					456.5					435.5				

CHPL	CHM 90					CHM 110					CHM 130					
	Lv	I	H	M	N	Lv	I	H	M	N	Lv	I	H	M	N	
16001	-					279					286					
16002	336.5					364	110	237.5	127.5	160	371	130	277.5	147.5	180	
16003	397.5	90	193	103	129.5											
16004	445.5															

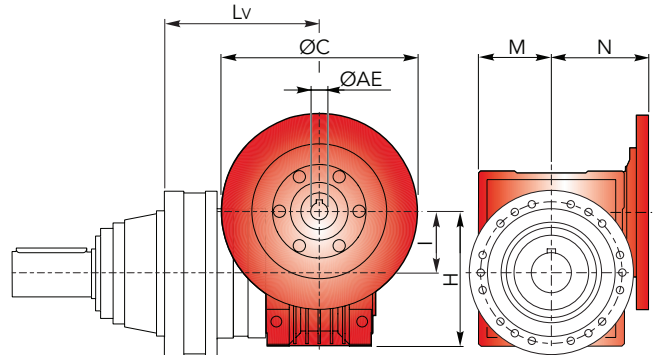

## CHPLB 16000 CMC - Flange motori IEC

## CHPLB 16000 CMC - IEC Motor flanges

CHPLB	IEC 63				IEC 71				IEC 80				IEC 90			
	L	Lp	P	ØD	L	Lp	P	ØD	L	Lp	P	ØD	L	Lp	P	ØD
16002	229				229	276	36	140	229	296	56	200	229	296	56	200
16003	314	276	36	140	314	276	36	160	314	296	56	200	314	296	56	200
16004	348.5	196			348.5	196			348.5	216			348.5	216		

CHPLB	IEC 100				IEC 112				IEC 132				IEC 160				IEC 180			
	L	Lp	P	ØD	L	Lp	P	ØD	L	Lp	P	ØD	L	Lp	P	ØD	L	Lp	P	ØD
16002	229				229	306	66	250	229	340	100	300	229	379	139	350	229	379	139	350
16003	314	306	66	250	314	306	66	250	314	340	100	300	314	379	139	350				
16004	348.5	226			348.5	226			348.5	260			348.5	299						

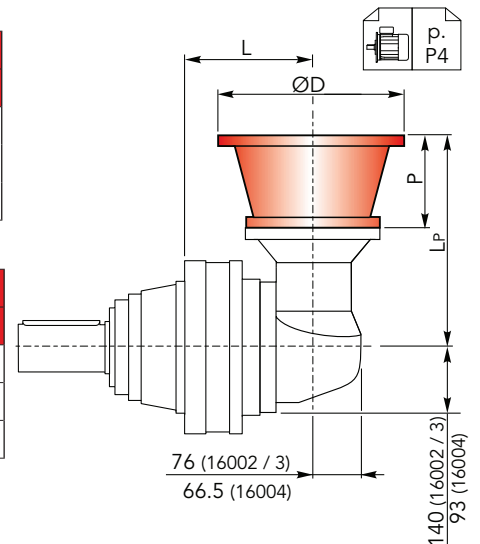

## CHPLB 16000 CMC - Alberi maschi entrata

## CHPL 16000 CMC - Male input shafts

CHPLB	CM42					CM65					CP65				
	L	Lt	T	Le	ØE	L	Lt	T	Le	ØE	L	Lt	T	Le	ØE
16002	229					229	377.5				229	409			
16003	314	333	93	82	42 h6	314	377.5	121.5	105	65 h6	314	409	153	105	65 h6
16004	348.5	253				348.5	297.5				348.5	329			

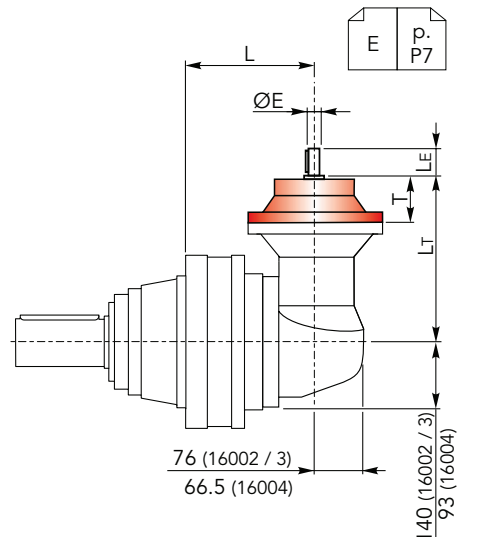



## DIMENSIONI CPS

## CPS DIMENSIONS

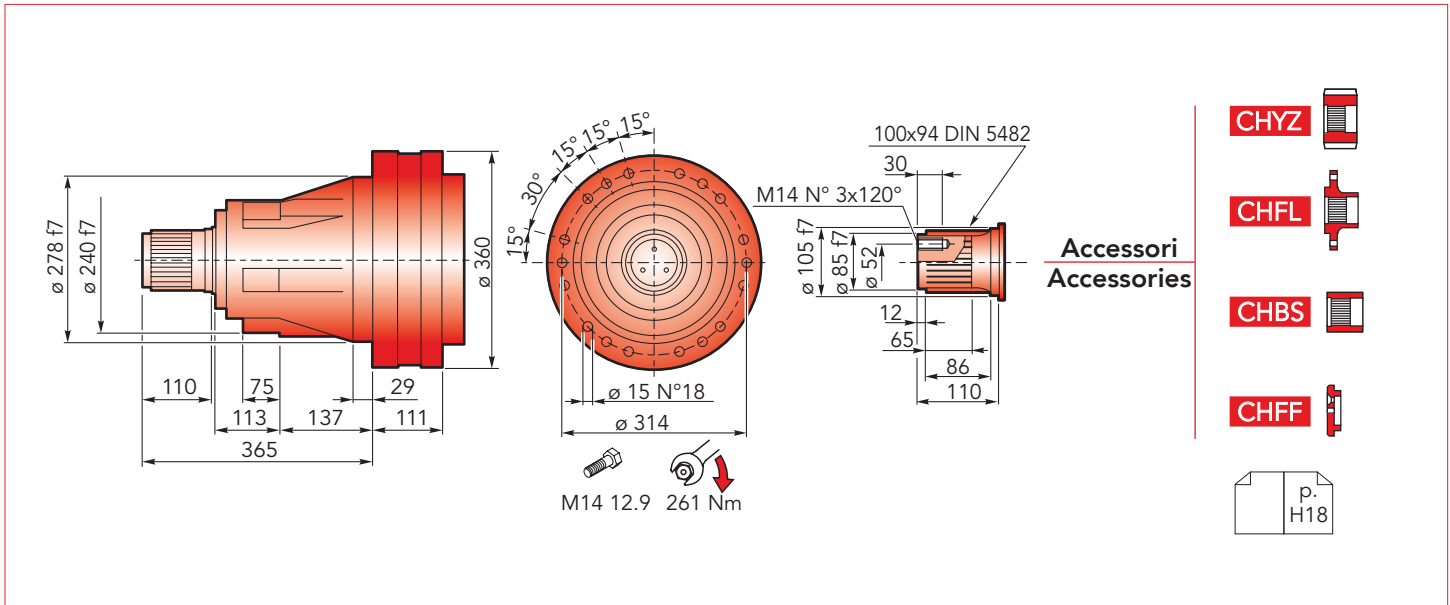

### CHPL 16000 CPS - Flange motori IEC

### CHPL 16000 CPS- IEC Motor flanges

CHPL	IEC 63			IEC 71			IEC 80			IEC 90			IEC 100		
	Lp	P	ØD	Lp	P	ØD	Lp	P	ØD	Lp	P	ØD	Lp	P	ØD
16001	-			-			-			-			-		
16002	248.5			248.5			268.5			268.5			278.5		
16003	309.5	36	140	309.5	36	160	329.5	56	200	329.5	56	200	339.5	66	250
16004	357.5			357.5			377.5			377.5			387.5		

CHPL	IEC 112			IEC 132			IEC 160			IEC 180			IEC 200			IEC 225		
	Lp	P	ØD	Lp	P	ØD	Lp	P	ØD	Lp	P	ØD	Lp	P	ØD	Lp	P	ØD
16001	-			-			259	118	350	259	118	350	289	148	400	280	139	450
16002	278.5			312.5			351.5			351.5	139	350	-			-		
16003	339.5	66	250	373.5	100	300	412.5	139	350	-			-			-		
16004	387.5			421.5			-			-			-			-		

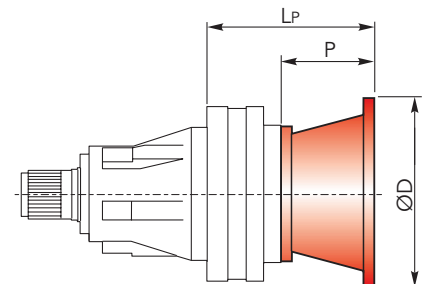

### CHPL 16000 CPS - Alberi maschi entrata

### CHPL 16000 CPS - Male input shafts

CHPL	CM42				CM65				CP65				
	Lt	T	Le	ØE	Lt	T	Le	ØE	Lt	T	Le	ØE	
16001	-				262.5				294				
16002	305.5				347.5	121.5	105	65 h6	379	153	105	65 h6	
16003	366.5	93	82	42 h6	-			-			-		
16004	414.5				-			-			-		

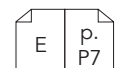
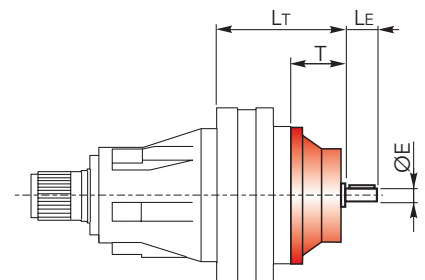



## DIMENSIONI CPS

## CPS DIMENSIONS

CHPL/CHPLB 16000

### CHPL 16000 CPS - Riduttore a vite senza fine CHM in entrata

### CHPL 16000 CPS - CHM input worm gearboxes

CHPL	CHM 50					CHM 63					CHM 75				
	Lv	I	H	M	N	Lv	I	H	M	N	Lv	I	H	M	N
16001	-					-					-				
16002	338					347.5					326.5				
16003	399	50	110	60	80	408.5	63	135	72	95	387.5	75	161	86	112.5
16004	447					456.5					435.5				

CHPL	CHM 90					CHM 110					CHM 130					
	Lv	I	H	M	N	Lv	I	H	M	N	Lv	I	H	M	N	
16001	-					279					286					
16002	336.5					364	110	237.5	127.5	160	371	130	277.5	147.5	180	
16003	397.5	90	193	103	129.5											
16004	445.5															

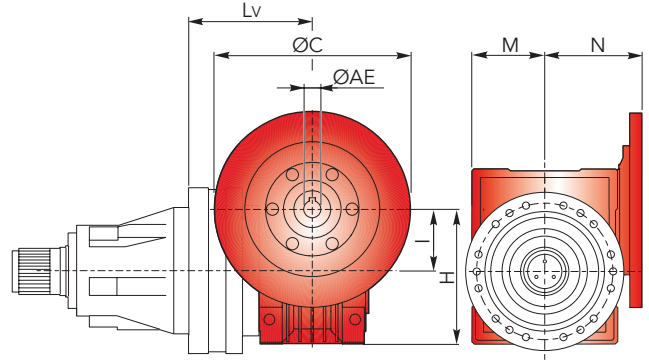

### CHPLB 16000 CPS - Flange motori IEC

### CHPLB 16000 CPS - IEC Motor flanges

CHPLB	IEC 63				IEC 71				IEC 80				IEC 90			
	L	Lp	P	ØD	L	Lp	P	ØD	L	Lp	P	ØD	L	Lp	P	ØD
16002	229				229				229				229			
16003	314	276	36	140	314	276	36	160	314	296	56	200	314	296	56	200
16004	348.5	196			348.5	196			348.5	216			348.5	216		

CHPLB	IEC 100				IEC 112				IEC 132				IEC 160				IEC 180			
	L	Lp	P	ØD	L	Lp	P	ØD	L	Lp	P	ØD	L	Lp	P	ØD	L	Lp	P	ØD
16002	229				229				229				229				229	379	139	350
16003	314	306	66	250	314	306	66	250	314	340	100	300	314	379	139	350				
16004	348.5	226			348.5	226			348.5	260			348.5	299						

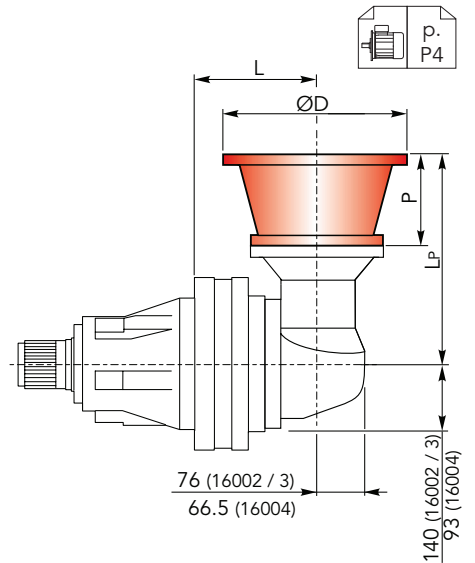

### CHPLB 16000 CPS - Alberi maschi entrata

### CHPL 16000 CPS - Male input shafts

CHPLB	CM42					CM65					CP65				
	L	Lt	T	Le	ØE	L	Lt	T	Le	ØE	L	Lt	T	Le	ØE
16002	229					229					229				
16003	314	333	93	82	42 h6	314	377.5	121.5	105	65 h6	314	409	153	105	65 h6
16004	348.5	253				348.5	297.5				348.5	329			

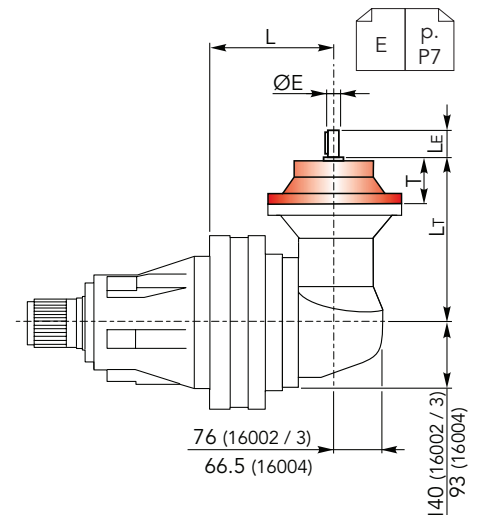



## DIMENSIONI CPC

## CPC DIMENSIONS

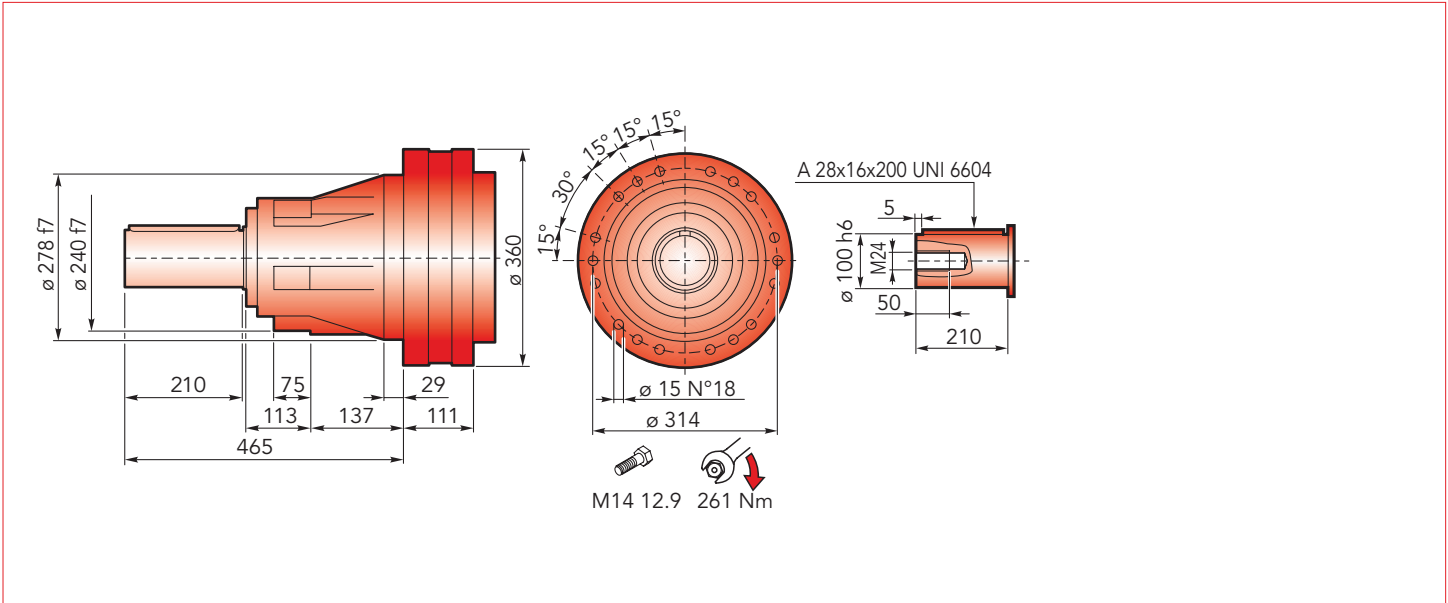

### CHPL 16000 CPC - Flange motori IEC

### CHPL 16000 CPC- IEC Motor flanges

CHPL	IEC 63			IEC 71			IEC 80			IEC 90			IEC 100		
	Lp	P	ØD	Lp	P	ØD	Lp	P	ØD	Lp	P	ØD	Lp	P	ØD
16001	-			-			-			-			-		
16002	248.5			248.5			268.5			268.5			278.5		
16003	309.5	36	140	309.5	36	160	329.5	56	200	329.5	56	200	339.5	66	250
16004	357.5			357.5			377.5			377.5			387.5		

CHPL	IEC 112			IEC 132			IEC 160			IEC 180			IEC 200			IEC 225		
	Lp	P	ØD	Lp	P	ØD	Lp	P	ØD	Lp	P	ØD	Lp	P	ØD	Lp	P	ØD
16001	-			-			259	118	350	259	118	350	289	148	400	280	139	450
16002	278.5			312.5			351.5			351.5	139	350	-			-		
16003	339.5	66	250	373.5	100	300	412.5	139	350	-			-			-		
16004	387.5			421.5			-			-			-			-		

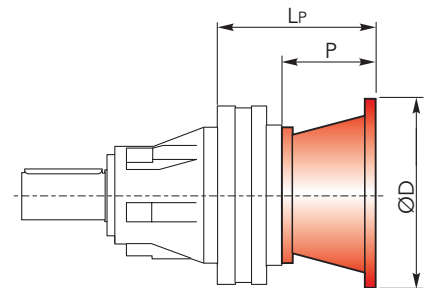

### CHPL 16000 CPC - Alberi maschi entrata

### CHPL 16000 CPC - Male input shafts

CHPL	CM42				CM65				CP65				
	Lt	T	Le	ØE	Lt	T	Le	ØE	Lt	T	Le	ØE	
16001	-				262.5				294				
16002	305.5				347.5	121.5	105	65 h6	379	153	105	65 h6	
16003	366.5	93	82	42 h6	-			-			-		
16004	414.5				-			-			-		

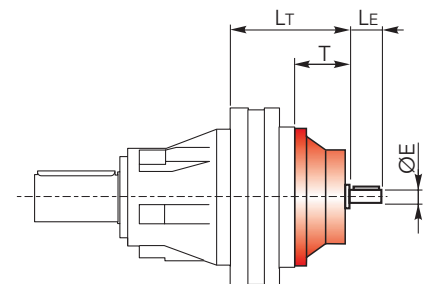



## DIMENSIONI CPC

## CPC DIMENSIONS

CHPL/CHPLB 16000

CHPL 16000 CPC - Riduttore a vite senza fine CHM in entrata

CHPL 16000 CPC - CHM input worm gearboxes

CHPL	CHM 50					CHM 63					CHM 75				
	Lv	I	H	M	N	Lv	I	H	M	N	Lv	I	H	M	N
16001	-					-					-				
16002	338					347.5					326.5				
16003	399	50	110	60	80	408.5	63	135	72	95	387.5	75	161	86	112.5
16004	447					456.5					435.5				

CHPL	CHM 90					CHM 110					CHM 130				
	Lv	I	H	M	N	Lv	I	H	M	N	Lv	I	H	M	N
16001	-					-					-				
16002	336.5					364	110	237.5	127.5	160	286	130	277.5	147.5	180
16003	397.5	90	193	103	129.5										
16004	445.5														

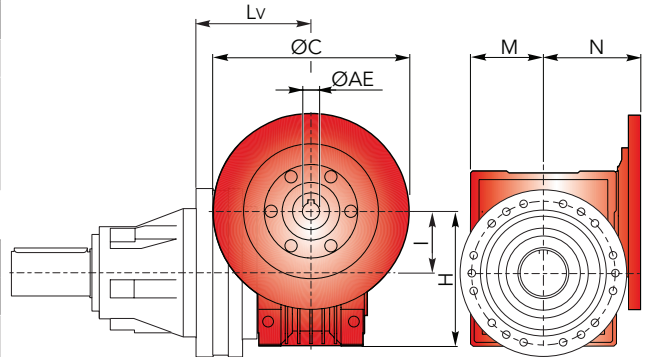

CHPLB 16000 CPC - Flange motori IEC

CHPLB 16000 CPC - IEC Motor flanges

CHPLB	IEC 63				IEC 71				IEC 80				IEC 90			
	L	Lp	P	ØD	L	Lp	P	ØD	L	Lp	P	ØD	L	Lp	P	ØD
16002	229				229	276	36	140	229	296	56	200	229	296	56	200
16003	314	276	36	140	314	276	36	160	314	296	56	200	314	296	56	200
16004	348.5	196			348.5	196			348.5	216			348.5	216		

CHPLB	IEC 100				IEC 112				IEC 132				IEC 160				IEC 180			
	L	Lp	P	ØD	L	Lp	P	ØD	L	Lp	P	ØD	L	Lp	P	ØD	L	Lp	P	ØD
16002	229				229	306	66	250	229	340	100	300	229	379	139	350	229	379	139	350
16003	314	306	66	250	314	306	66	250	314	340	100	300	314	379	139	350				
16004	348.5	226			348.5	226			348.5	260			348.5	299						

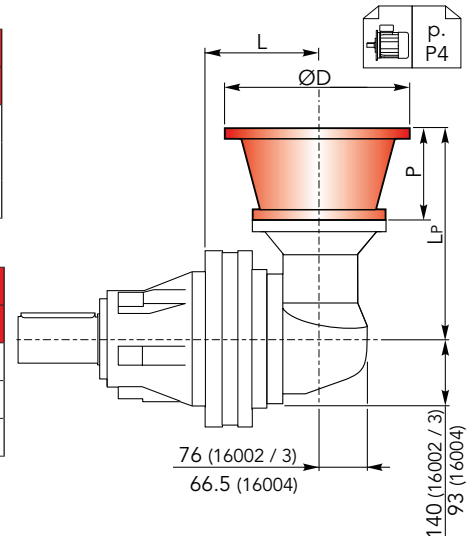

CHPLB 16000 CPC - Alberi maschi entrata

CHPL 16000 CPC - Male input shafts

CHPLB	CM42					CM65					CP65				
	L	Lt	T	Le	ØE	L	Lt	T	Le	ØE	L	Lt	T	Le	ØE
16002	229					229	377.5				229	409			
16003	314	333	93	82	42 h6	314	377.5	121.5	105	65 h6	314	409	153	105	65 h6
16004	348.5	253				348.5	297.5				348.5	329			

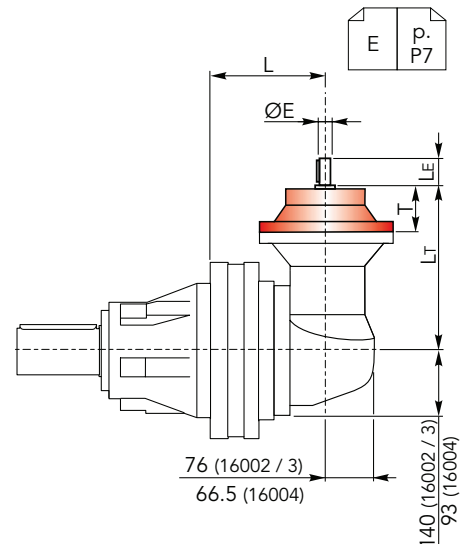

## DIMENSIONI CF

## CF DIMENSIONS

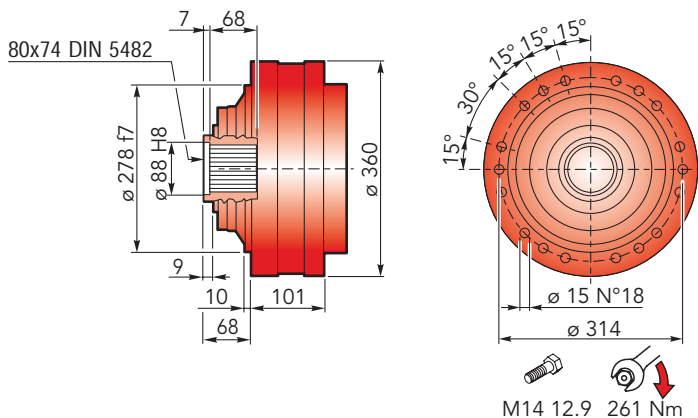

### CHPL 16000 CF - Flange motori IEC

### CHPL 16000 CF- IEC Motor flanges

CHPL	IEC 63			IEC 71			IEC 80			IEC 90			IEC 100		
	LP	P	ØD	LP	P	ØD	LP	P	ØD	LP	P	ØD	LP	P	ØD
16001	-	-	-	-	-	-	-	-	-	-	-	-	-	-	-
16002	238.5	-	-	238.5	-	-	258.5	-	-	258.5	-	-	268.5	-	-
16003	299.5	36	140	299.5	36	160	319.5	56	200	319.5	56	200	329.5	66	250
16004	347.5	-	-	347.5	-	-	367.5	-	-	367.5	-	-	377.5	-	-

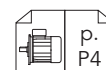
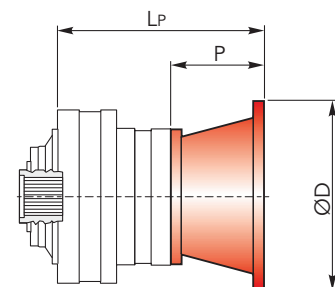

CHPL	IEC 112			IEC 132			IEC 160			IEC 180			IEC 200			IEC 225		
	LP	P	ØD	LP	P	ØD	LP	P	ØD	LP	P	ØD	LP	P	ØD	LP	P	ØD
16001	-	-	-	-	-	-	249	118	350	249	118	350	279	148	400	270	139	450
16002	268.5	-	-	302.5	-	-	341.5	-	-	341.5	139	350	-	-	-	-	-	-
16003	329.5	66	250	363.5	100	300	402.5	139	350	-	-	-	-	-	-	-	-	-
16004	377.5	-	-	411.5	-	-	450.5	-	-	-	-	-	-	-	-	-	-	-

### CHPL 16000 CF - Alberi maschi entrata

### CHPL 16000 CF - Male input shafts

CHPL	CM42				CM65				CP65				
	LT	T	LE	ØE	LT	T	LE	ØE	LT	T	LE	ØE	
16001	-	-	-	-	252.5	-	-	-	284	-	-	-	-
16002	295.5	-	-	-	337.5	121.5	105	65 h6	369	153	105	65 h6	-
16003	356.5	93	82	42 h6	-	-	-	-	-	-	-	-	-
16004	404.5	-	-	-	-	-	-	-	-	-	-	-	-

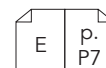
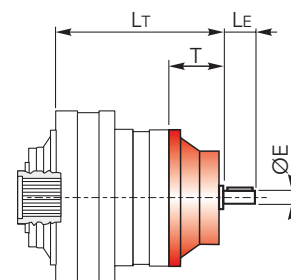



## DIMENSIONI CF

## CF DIMENSIONS

CHPL/CHPLB 16000

CHPL 16000 CF - Riduttore a vite senza fine CHM in entrata

CHPL 16000 CF - CHM input worm gearboxes

CHPL	CHM 50					CHM 63					CHM 75				
	Lv	I	H	M	N	Lv	I	H	M	N	Lv	I	H	M	N
16001	-					-					-				
16002	328					337.5					316.5				
16003	389	50	110	60	80	398.5	63	135	72	95	377.5	75	161	86	112.5
16004	437					446.5					425.5				

CHPL	CHM 90					CHM 110					CHM 130					
	Lv	I	H	M	N	Lv	I	H	M	N	Lv	I	H	M	N	
16001	-					269					276					
16002	326.5					354	110	237.5	127.5	160	361	130	277.5	147.5	180	
16003	387.5	90	193	103	129.5	-					-					
16004	435.5					-					-					

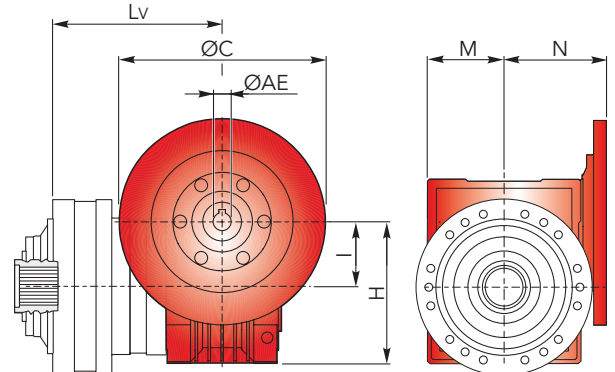

CHPLB 16000 CF - Flange motori IEC

CHPLB 16000 CF - IEC Motor flanges

CHPLB	IEC 63				IEC 71				IEC 80				IEC 90			
	L	Lp	P	ØD	L	Lp	P	ØD	L	Lp	P	ØD	L	Lp	P	ØD
16002	219				219				219				219			
16003	304	276	36	140	304	276	36	160	304	296	56	200	304	296	56	200
16004	338.5	196			338.5	196			338.5	216			338.5	216		

CHPLB	IEC 100				IEC 112				IEC 132				IEC 160				IEC 180			
	L	Lp	P	ØD	L	Lp	P	ØD	L	Lp	P	ØD	L	Lp	P	ØD	L	Lp	P	ØD
16002	219				219				219				219				219	379	139	350
16003	304	306	66	250	304	306	66	250	304	340	100	300	304	379	139	350	-			
16004	338.5	226			338.5	226			338.5	260			338.5	299			-			

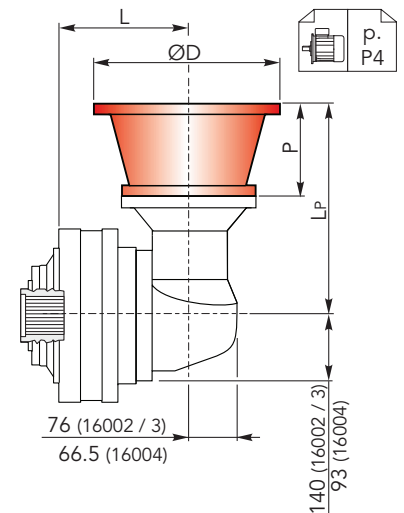

CHPLB 16000 CF - Alberi maschi entrata

CHPL 16000 CF - Male input shafts

CHPLB	CM42					CM65					CP65				
	L	Lt	T	Le	ØE	L	Lt	T	Le	ØE	L	Lt	T	Le	ØE
16002	219					219					219				
16003	304	333	93	82	42 h6	304	377.5	121.5	105	65 h6	304	409	153	105	65 h6
16004	338.5	253				338.5	297.5				338.5	329			

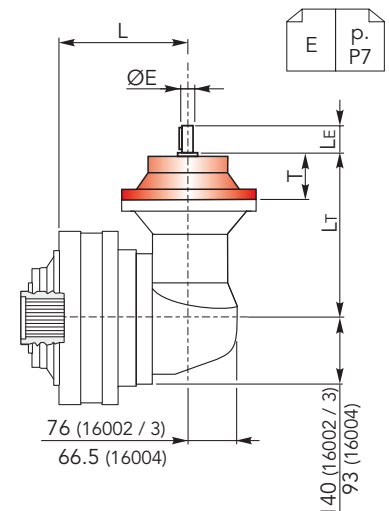



## DIMENSIONI CFS

## CFS DIMENSIONS

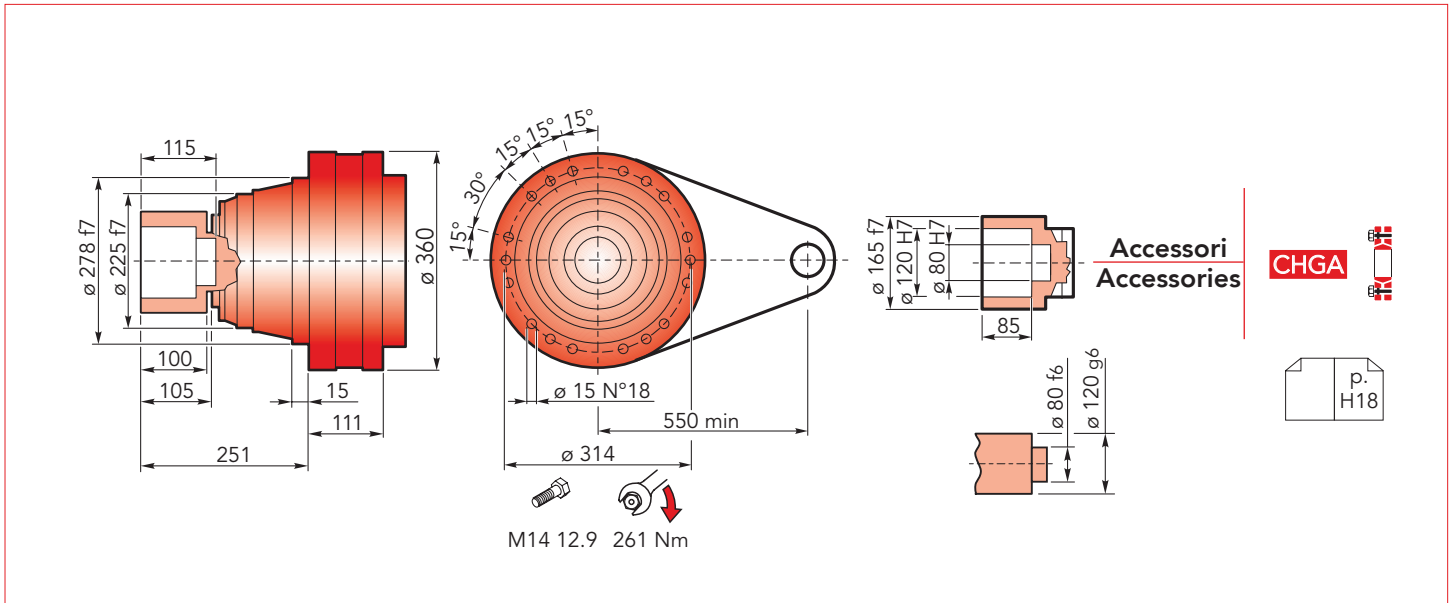

### CHPL 16000 CFS - Flange motori IEC

### CHPL 16000 CFS- IEC Motor flanges

CHPL	IEC 63			IEC 71			IEC 80			IEC 90			IEC 100		
	LP	P	ØD	LP	P	ØD	LP	P	ØD	LP	P	ØD	LP	P	ØD
16001	-			-			-			-			-		
16002	248.5			248.5			268.5			268.5			278.5		
16003	309.5	36	140	309.5	36	160	329.5	56	200	329.5	56	200	339.5	66	250
16004	357.5			357.5			377.5			377.5			387.5		

CHPL	IEC 112			IEC 132			IEC 160			IEC 180			IEC 200			IEC 225		
	LP	P	ØD	LP	P	ØD	LP	P	ØD	LP	P	ØD	LP	P	ØD	LP	P	ØD
16001	-			-			259	118	350	259	118	350	289	148	400	280	139	450
16002	278.5			312.5			351.5			351.5	139	350	-			-		
16003	339.5	66	250	373.5	100	300	412.5	139	350	-			-			-		
16004	387.5			421.5			-			-			-			-		

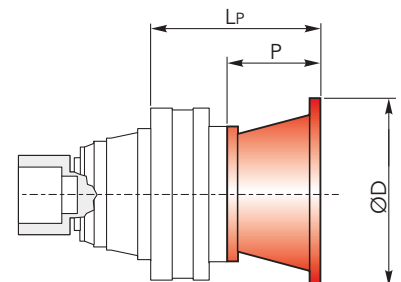

### CHPL 16000 CFS - Alberi maschi entrata

### CHPL 16000 CFS - Male input shafts

CHPL	CM42				CM65				CP65				
	LT	T	LE	ØE	LT	T	LE	ØE	LT	T	LE	ØE	
16001	-				262.5				294				
16002	305.5				347.5	121.5	105	65 h6	379	153	105	65 h6	
16003	366.5	93	82	42 h6	-			-			-		
16004	414.5				-			-			-		

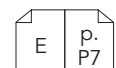
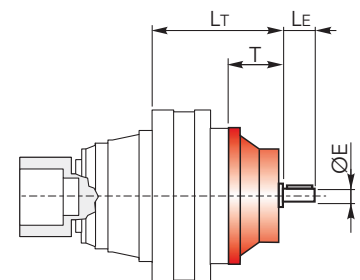





## DIMENSIONI CFS

## CFS DIMENSIONS

CHPL/CHPLB 16000

CHPL 16000 CFS - Riduttore a vite senza fine CHM in entrata CHPL 16000 CFS - CHM input worm gearboxes

CHPL	CHM 50					CHM 63					CHM 75				
	Lv	I	H	M	N	Lv	I	H	M	N	Lv	I	H	M	N
16001	-					-					-				
16002	338					347.5					326.5				
16003	399	50	110	60	80	408.5	63	135	72	95	387.5	75	161	86	112.5
16004	447					456.5					435.5				

CHPL	CHM 90					CHM 110					CHM 130				
	Lv	I	H	M	N	Lv	I	H	M	N	Lv	I	H	M	N
16001	-					-					-				
16002	336.5					364	110	237.5	127.5	160	371	130	277.5	147.5	180
16003	397.5	90	193	103	129.5										
16004	445.5														

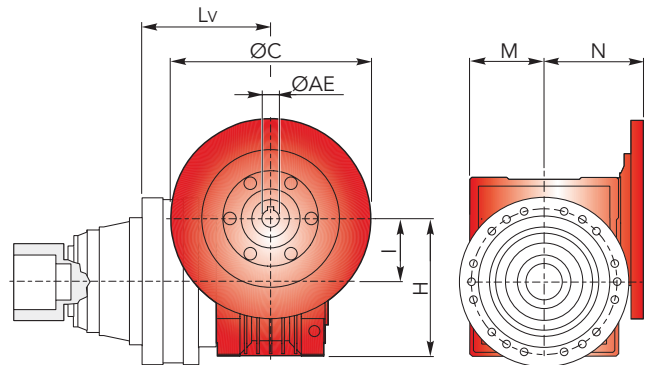

## CHPLB 16000 CFS - Flange motori IEC

## CHPLB 16000 CFS - IEC Motor flanges

CHPLB	IEC 63				IEC 71				IEC 80				IEC 90			
	L	Lp	P	ØD	L	Lp	P	ØD	L	Lp	P	ØD	L	Lp	P	ØD
16002	229				229				229				229			
16003	314	276	36	140	314	276	36	160	314	296	56	200	314	296	56	200
16004	348.5	196			348.5	196			348.5	216			348.5	216		

CHPLB	IEC 100				IEC 112				IEC 132				IEC 160				IEC 180				
	L	Lp	P	ØD	L	Lp	P	ØD	L	Lp	P	ØD	L	Lp	P	ØD	L	Lp	P	ØD	
16002	229				229				229				229				229				350
16003	314	306	66	250	314	306	66	250	314	340	100	300	314	379	139	350					
16004	348.5	226			348.5	226			348.5	260			348.5	299							

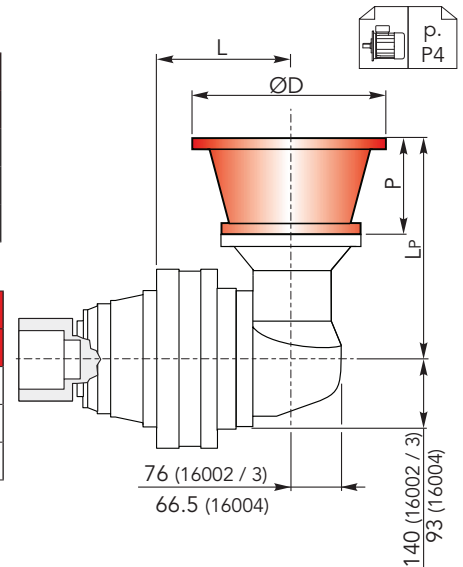

## CHPLB 16000 CFS - Alberi maschi entrata

## CHPL 16000 CFS - Male input shafts

CHPLB	CM42					CM65					CP65				
	L	Lt	T	Le	ØE	L	Lt	T	Le	ØE	L	Lt	T	Le	ØE
16002	229					229					229				
16003	314	333	93	82	42 h6	314	377.5	121.5	105	65 h6	314	409	153	105	65 h6
16004	348.5	253				348.5	297.5				348.5	329			

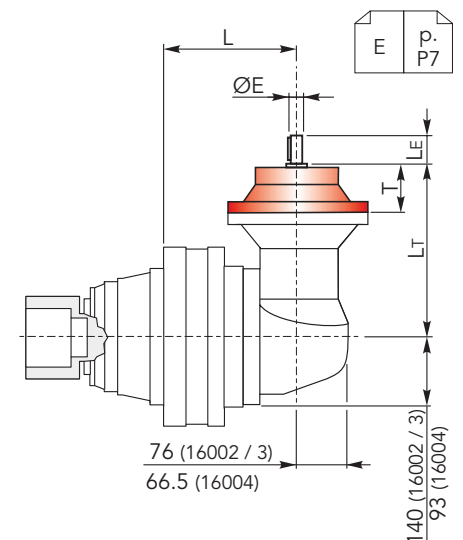



## DIMENSIONI CCPC

## CCPC DIMENSIONS

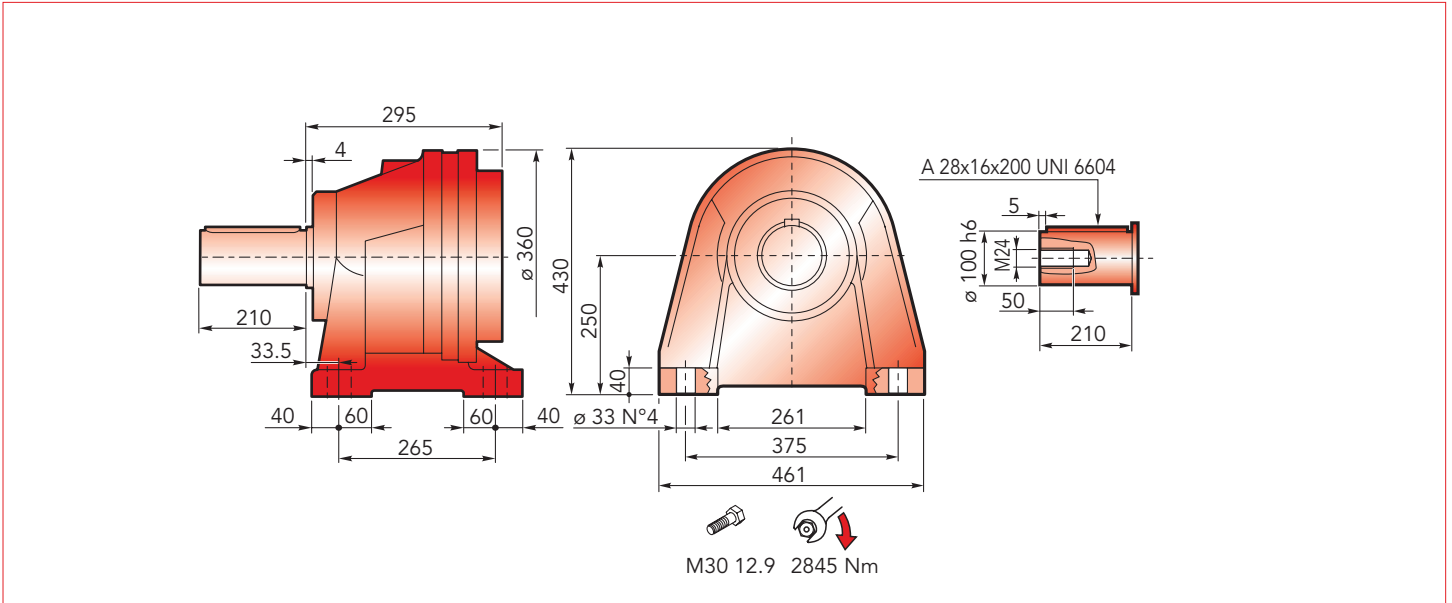

### CHPL 16000 CCPC - Flange motori IEC

### CHPL 16000 CCPC- IEC Motor flanges

CHPL	IEC 63			IEC 71			IEC 80			IEC 90			IEC 100		
	Lp	P	ØD	Lp	P	ØD	Lp	P	ØD	Lp	P	ØD	Lp	P	ØD
16001	-			-			-			-			-		
16002	352.5			352.5			372.5			372.5			382.5		
16003	463.5	36	140	463.5	36	160	483.5	56	200	483.5	56	200	493.5	66	250
16004	511.5			511.5			531.5			531.5			541.5		

CHPL	IEC 112			IEC 132			IEC 160			IEC 180			IEC 200			IEC 225		
	Lp	P	ØD	Lp	P	ØD	Lp	P	ØD	Lp	P	ØD	Lp	P	ØD	Lp	P	ØD
16001	-			-			413	118	350	413	118	350	443	148	400	434	139	450
16002	382.5			416.5			455.5			455.5	139	350	-			-		
16003	493.5	66	250	527.5	100	300	566.5	139	350	-			-			-		
16004	541.5			575.5			614.5			-			-			-		

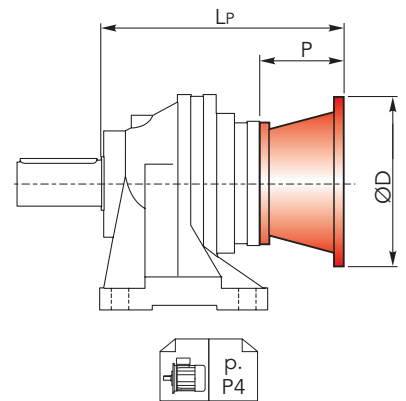

### CHPL 16000 CCPC - Alberi maschi entrata

### CHPL 16000 CCPC - Male input shafts

CHPL	CM42				CM65				CP65			
	Lt	T	Le	ØE	Lt	T	Le	ØE	Lt	T	Le	ØE
16001	-				416.5				448			
16002	409.5				451.5	121.5	105	65 h6	483	153	105	65 h6
16003	520.5	93	82	42 h6	-				-			
16004	568.5				-				-			

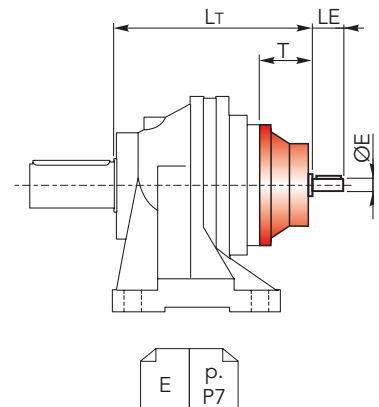



## DIMENSIONI CCPC

## CCPC DIMENSIONS

CHPL/CHPLB 16000

CHPL 16000 CCPC - Riduttore a vite senza fine CHM in entrata CHPL 16000 CCPC - CHM input worm gearboxes

CHPL	CHM 50					CHM 63					CHM 75				
	Lv	I	H	M	N	Lv	I	H	M	N	Lv	I	H	M	N
16001	-					-					-				
16002	442					451.5					430.5				
16003	553	50	110	60	80	562.5	63	135	72	95	541.5	75	161	86	112.5
16004	601					610.5					589.5				

CHPL	CHM 90					CHM 110					CHM 130					
	Lv	I	H	M	N	Lv	I	H	M	N	Lv	I	H	M	N	
16001	-					433					440					
16002	440.5					468	110	237.5	127.5	160	475	130	277.5	147.5	180	
16003	551.5	90	193	103	129.5	-					-					
16004	599.5					-					-					

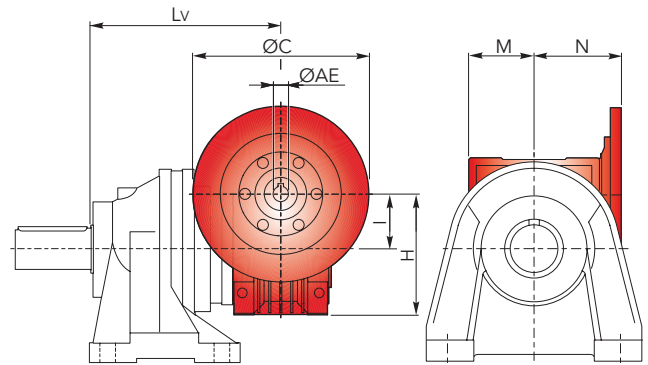

## CHPLB 16000 CCPC - Flange motori IEC

## CHPLB 16000 CCPC - IEC Motor flanges

CHPLB	IEC 63				IEC 71				IEC 80				IEC 90			
	L	Lp	P	ØD	L	Lp	P	ØD	L	Lp	P	ØD	L	Lp	P	ØD
16002	383				383				383				383			
16003	468	276	36	140	468	276	36	160	468	296	56	200	468	296	56	200
16004	502.5	196			502.5	196			502.5	216			502.5	216		

CHPLB	IEC 100				IEC 112				IEC 132				IEC 160				IEC 180			
	L	Lp	P	ØD	L	Lp	P	ØD	L	Lp	P	ØD	L	Lp	P	ØD	L	Lp	P	ØD
16002	383				383				383				383				383	379	139	350
16003	468	306	66	250	468	306	66	250	468	340	100	300	468	379	139	350	-			
16004	502.5	226			502.5	226			502.5	260			502.5	299			-			

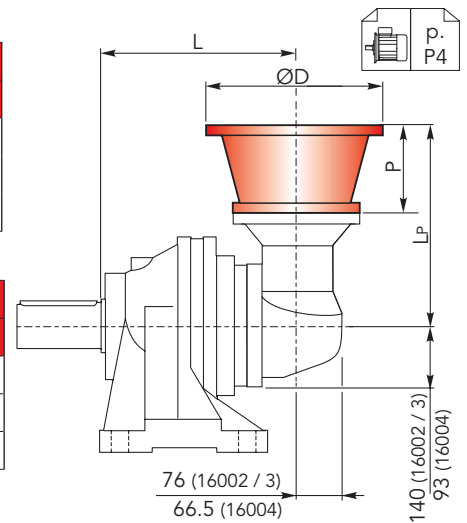

## CHPLB 16000 CCPC - Alberi maschi entrata

## CHPL 16000 CCPC - Male input shafts

CHPLB	CM42					CM65					CP65				
	L	Lt	T	Le	ØE	L	Lt	T	Le	ØE	L	Lt	T	Le	ØE
16002	383					383					383				
16003	468	333	93	82	42 h6	468	377.5	121.5	105	65 h6	468	409	153	105	65 h6
16004	502.5	253				502.5	297.5				502.5	329			

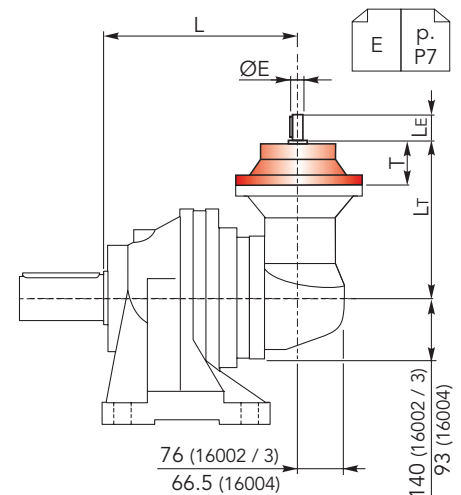



## ACCESSORI

## ACCESSORIES

### CHYZ Pignoni / Pinions

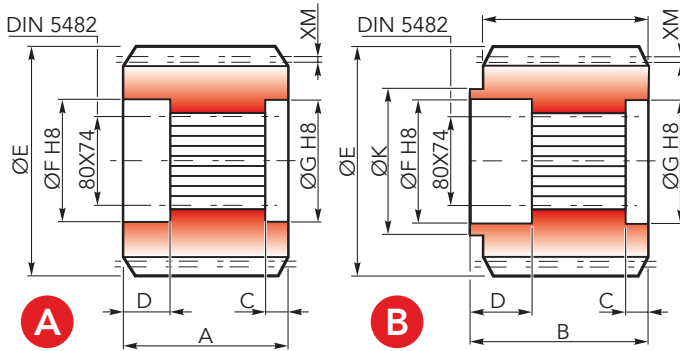

	Uscita / Output	M	Z	XM	A	B	C	D	E	F	G	K	Codice / Code
A	CMS	10	12	0	90	-	10	31	140	85	80	-	1071.236.042
	CMS	10	14	0	90	-	10	31	160	85	80	-	1071.238.042
	CPS	14	13	7	122	-	24	33	224	105	105	-	1071.293.042
B	CMS	12	14	3	90	115	25	31	194.5	85	80	130	1071.286.042

### CHFF Fondello di arresto / Stop bottom plate

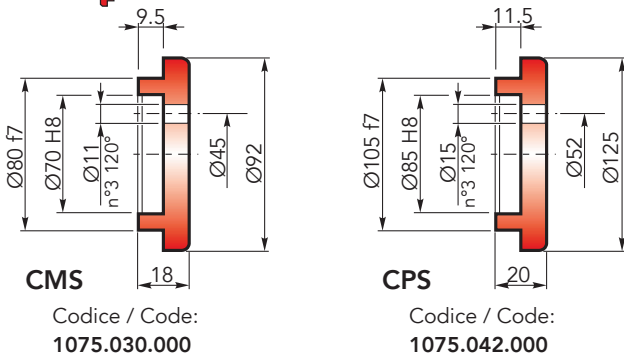

### CHBS Boccola scanalata / Splined bushing

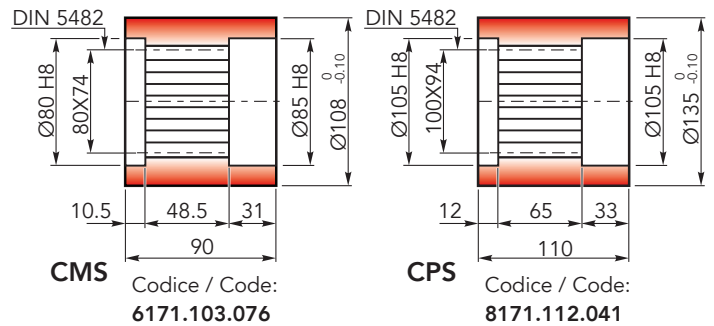

### CHKB Barra scanalata / Splined rod

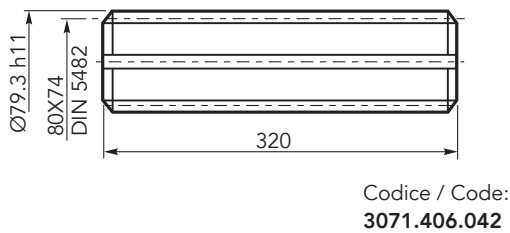

### CHGA Giunto di attrito / Shrink disc

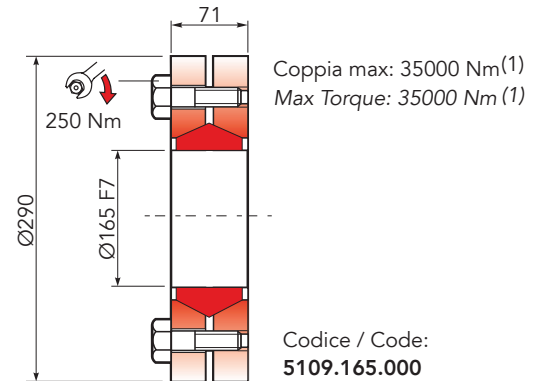

### CHFL Flangia / Flange

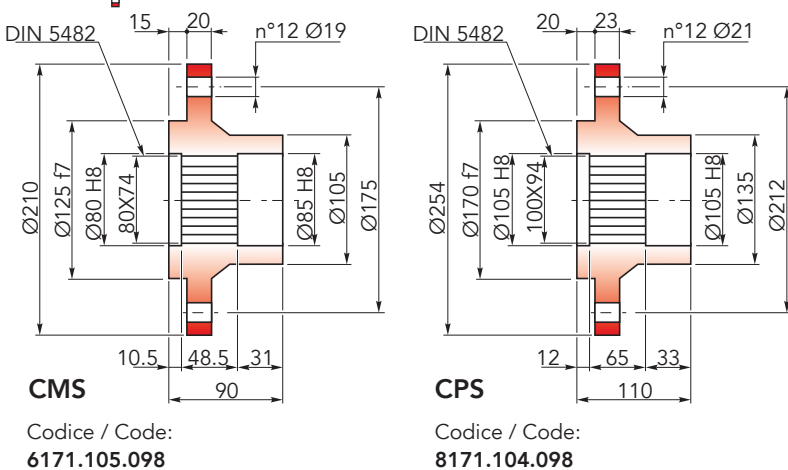

(1): Coppia max indicata è valida solo con calettatori forniti da Chiaravalli S.p.A.  
(1): The maximum torque indicated is valid only with shrink discs supplied by Chiaravalli S.p.A.



## CARICHI RADIALI (Fr)

## RADIAL LOADS (Fr)

Nel diagramma seguente, sono indicati i carichi radiali  $F_r$  (N) applicabili sull'albero uscita in funzione della distanza di applicazione  $L$  rispetto alla battuta dell'albero.

The hereunder table shows the allowable radial loads  $F_r$  (N) on the output shaft with reference to the distance  $L$ .

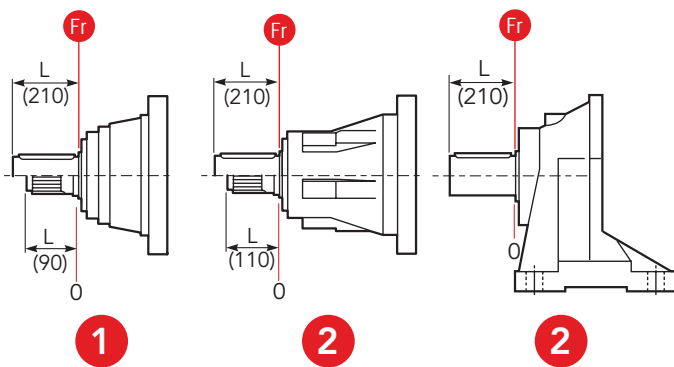
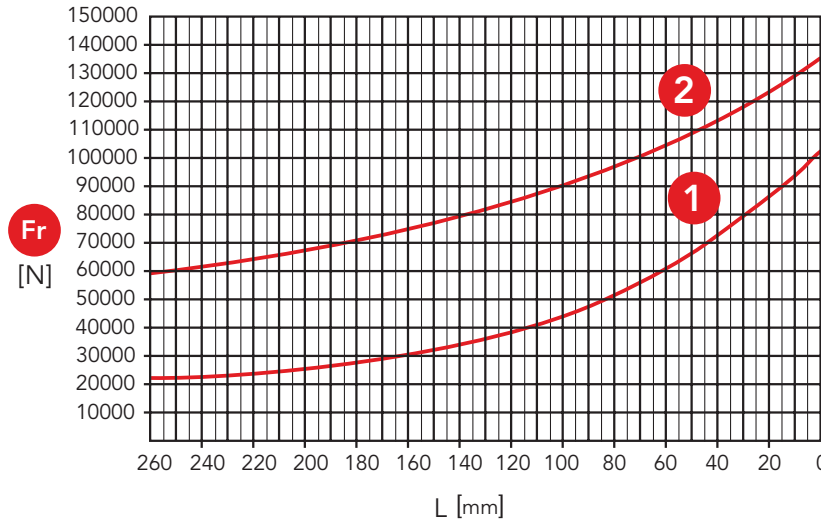

- 1** Uscita / Output: CMS, CMC
- 2** Uscita / Output: CPS, CPC, CCPC

## CARICHI ASSIALI (Fa)

## AXIAL LOADS (Fa)

Nella tabella seguente sono indicati i carichi assiali  $F_a$  (N) applicabili sull'albero di uscita in funzione della direzione di applicazione del carico e della versione.

The hereunder table shows the allowable axial loads  $F_a$  (N) on the output shaft with reference to the load direction and the output type.

	<b>1</b>	<b>2</b>	
<b>Fa</b> [N]	45000	85000	←
	65000	85000	→

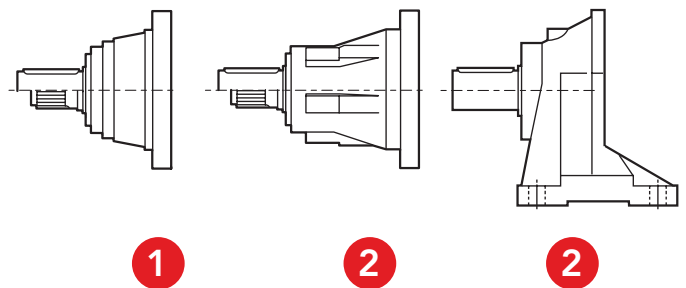

- 1** Uscita / Output: CMS, CMC
- 2** Uscita / Output: CPS, CPC, CCPC





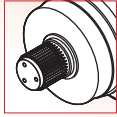
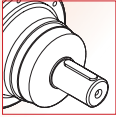
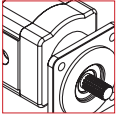
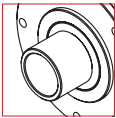
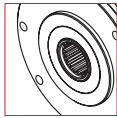
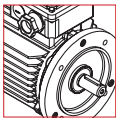
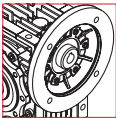
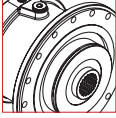

# CHPL/CHPLB 18000

	<b>i</b>	<b>T<sub>2n</sub></b> (daNm)	<b>OUT</b>		<b>IN</b>	
<b>18002</b>	13.0 ÷ 30.0	1146.7 ÷ 1314.8	 Ø100	 80X74 100X94 DIN 5482	 Ø42 Ø65	 Hydraulic Motor
<b>18003</b>	53.8 ÷ 180.2	1146.7 ÷ 1314.8	 Ø120	 80X74 DIN 5482	 Electric Motor	 Worm gearboxes
<b>18004</b>	348.6 ÷ 1216.4	1146.7 ÷ 1314.8			 Brake	

## CHPL

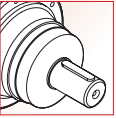
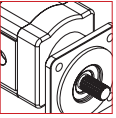
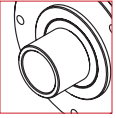
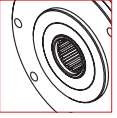
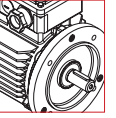
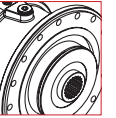

	<b>i</b>	<b>T<sub>2n</sub></b> (daNm)	<b>OUT</b>		<b>IN</b>	
<b>18002</b>	10.9 ÷ 20.0	1146.7 ÷ 1314.8	 Ø100	 80X74 100X94 DIN 5482	 Ø42 Ø65	 Hydraulic Motor
<b>18003</b>	54.4 ÷ 163.3	1146.7 ÷ 1314.8	 Ø120	 80X74 DIN 5482	 Electric Motor	
<b>18004</b>	185.8 ÷ 981.2	1146.7 ÷ 1314.8			 Brake	

## CHPLB

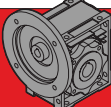

## DATI TECNICI

## TECHNICAL DATA

 <b>CHPL</b>	i	$T_{2n}$ ( $n_1=1400$ rpm) [daNm]	$P_{1n}$ ( $n_1=1400$ rpm) [kW]	$P_t$ [kW]	IEC (B5)	 <b>CHM</b>	 <b>CM / CP</b>
18002	13	1314.8	148	25	160   180	CHM 110 CHM 130	CM65 CP65
	15.7	1314.8	123				
	19	1146.7	88				
	21.4	1146.7	79				
	24.9	1146.7	68				
18003	30	1146.7	56	17	63   71 80   90 100   112 132   160	CHM 50 CHM 63 CHM 75 CHM 90 CHM 110 CHM 130	CM42 CM65 CP65
	53.8	1314.8	36				
	65	1314.8	30				
	73.3	1314.8	26				
	81.4	1314.8	24				
	94.5	1314.8	20				
	106.7	1314.8	18				
	128.4	1146.7	13				
18004	149.1	1146.7	11	13	63   71 80   90 100   112 132   160	CHM 50 CHM 63 CHM 75 CHM 90	CM42
	180.2	1146.7	9.3				
	348.6	1314.8	5.5				
	377.2	1314.8	5.1				
	438.4	1314.8	4.4				
	489.2	1314.8	3.9				
	549.1	1314.8	3.5				
	620	1314.8	3.1				
	677.9	1314.8	2.8				
	720	1314.8	2.7				
	770.5	1314.8	2.5				
	818.8	1314.8	2.4				
	849.8	1146.7	2.0				
	928.8	1146.7	1.8				
987.4	1146.7	1.7					
1113	1146.7	1.5					
1216.4	1146.7	1.4					



 $n_{1max} = 2800$  rpm



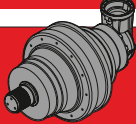

## DATI TECNICI

## TECHNICAL DATA

 CHPLB	i	T <sub>2n</sub> (n <sub>1</sub> =1400 rpm)	P <sub>1n</sub> (n <sub>1</sub> =1400 rpm)	P <sub>t</sub>	IEC	 CM / CP
		[daNm]	[kW]	[kW]	(B5)	
<b>18002</b>	10.9	1314.8	177	25	160   180	CM65 CP65
	13.2	1146.7	127			
	16.6	1314.8	116			
	20	1146.7	84			
<b>18003</b>	54.4	1314.8	35	17	63   71 80   90 100   112 132   160	CM42 CM65 CP65
	71.2	1314.8	27			
	85.7	1314.8	22			
	103.3	1146.7	16			
	116.7	1146.7	14			
	135.5	1314.8	14			
	163.3	1146.7	10			
<b>18004</b>	185.8	1314.8	10	13	63   71 80   90 100   112 132   160	CM42 CM65 CP65
	224.4	1314.8	8.6			
	281	1314.8	6.9			
	323.8	1314.8	6.0			
	353.6	1314.8	5.5			
	394.3	1314.8	4.9			
	442.9	1314.8	4.4			
	500.1	1314.8	3.9			
	558.2	1146.7	3.0			
	580.7	1314.8	3.3			
	622.5	1146.7	2.7			
	699.2	1146.7	2.4			
	749.1	1146.7	2.2			
	812	1146.7	2.1			
981.2	1146.7	1.7				

n<sub>1max</sub> = 2800 rpm



## DIMENSIONI CMS

## CMS DIMENSIONS

**Accessori**  
Accessories

- CHYZ**
- CHFL**
- CHBS**
- CHFF**

p. 118

### CHPL 18000 CMS - Flange motori IEC

### CHPL 18000 CMS- IEC Motor flanges

CHPL	IEC 63			IEC 71			IEC 80			IEC 90			IEC 100		
	LP	P	ØD	LP	P	ØD	LP	P	ØD	LP	P	ØD	LP	P	ØD
18002	-			-			-			-			-		
18003	336.5	36	140	336.5	36	160	356.5	56	200	356.5	56	200	366.5	66	250
18004	380.5			380.5			400.5			400.5			410.5		

CHPL	IEC 112			IEC 132			IEC 160			IEC 180		
	LP	P	ØD	LP	P	ØD	LP	P	ØD	LP	P	ØD
18002	-			-			359	118	350	359	118	350
18003	366.5	66	250	400.5	100	300	439.5	139		-		
18004	410.5			444.5			483.5			-		

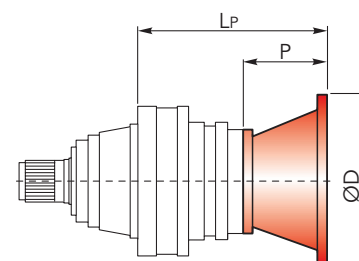

p. P4

### CHPL 18000 CMS - Alberi maschi entrata

### CHPL 18000 CMS - Male Input shafts

CHPL	CM42				CM65				CP65			
	LT	T	LE	ØE	LT	T	LE	ØE	LT	T	LE	ØE
18002	-				362.5	121.5	105	65 h6	394	153	105	65 h6
18003	393.5	93	82	42 h6	435.5				467			
18004	437.5				-				-			

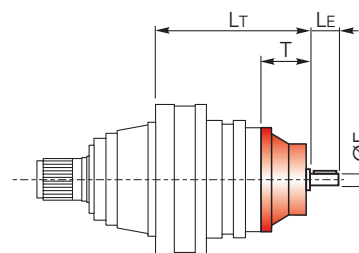

E p. P7



## DIMENSIONI CMS

## CMS DIMENSIONS

CHPL/CHPLB 18000

CHPL 18000 CMS - Riduttore a vite senza fine CHM in entrata

CHPL 18000 CMS - CHM input worm gearboxes

CHPL	CHM 50					CHM 63					CHM 75				
	Lv	I	H	M	N	Lv	I	H	M	N	Lv	I	H	M	N
18002	-					-					-				
18003	426	50	110	60	80	435.5	63	135	72	95	414.5	75	161	86	112.5
18004	470					479.5					458.5				

CHPL	CHM 90					CHM 110					CHM 130					
	Lv	I	H	M	N	Lv	I	H	M	N	Lv	I	H	M	N	
18002	-					379	110	237.5	127.5	160	386	130	277.5	147.5	180	
18003	424.5	90	193	103	129.5	452					459					
18004	468.5															

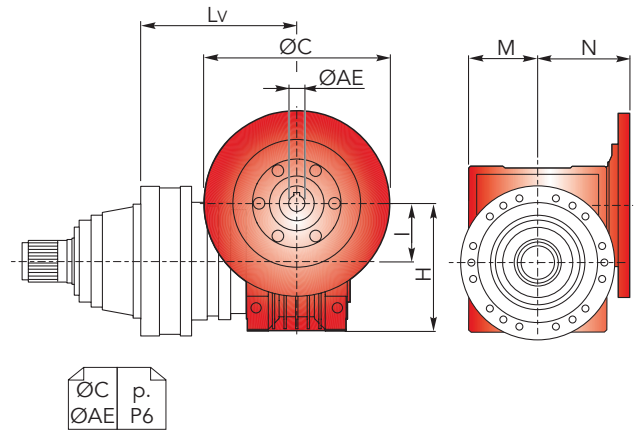

CHPLB 18000 CMS - Flange motori IEC

CHPLB 18000 CMS - IEC Motor flanges

CHPLB	IEC 63				IEC 71				IEC 80				IEC 90			
	L	LP	P	ØD	L	LP	P	ØD	L	LP	P	ØD	L	LP	P	ØD
18002	-				-				-				-			
18003	333	276	36	140	333	276	36	160	333	296	56	200	333	296	56	200
18004	406				406				406				406			

CHPLB	IEC 100				IEC 112				IEC 132				IEC 160				IEC 180				
	L	LP	P	ØD	L	LP	P	ØD	L	LP	P	ØD	L	LP	P	ØD	L	LP	P	ØD	
18002	-				-				-				276	433	118		276	433	118	350	
18003	333	306	66	250	333	306	66	250	333	340	100	300	333	379	139	350					
18004	406				406				406				406								

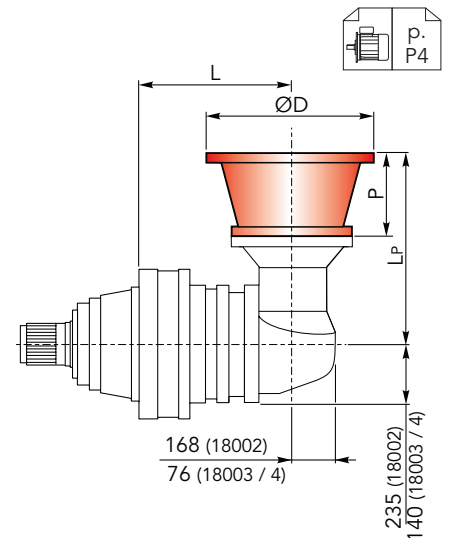

CHPLB 18000 CMS - Alberi maschi entrata

CHPL 18000 CMS - Male input shafts

CHPLB	CM42					CM65					CP65				
	L	Lt	T	Le	ØE	L	Lt	T	Le	ØE	L	Lt	T	Le	ØE
18002	-					276	436.5				276	468			
18003	333	333	93	82	42 h6	333	377.5	121.5	105	65 h6	333	409	153	105	65 h6
18004	406					406					406				

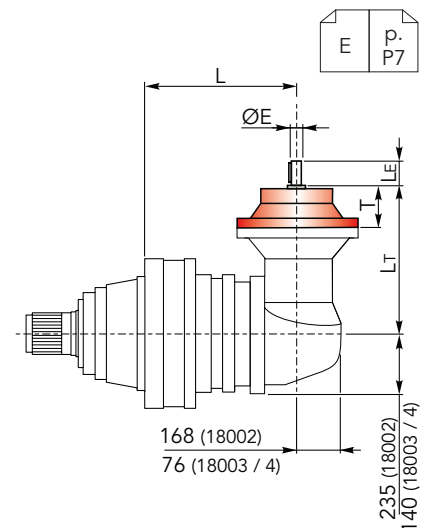



## DIMENSIONI CMC

## CMC DIMENSIONS

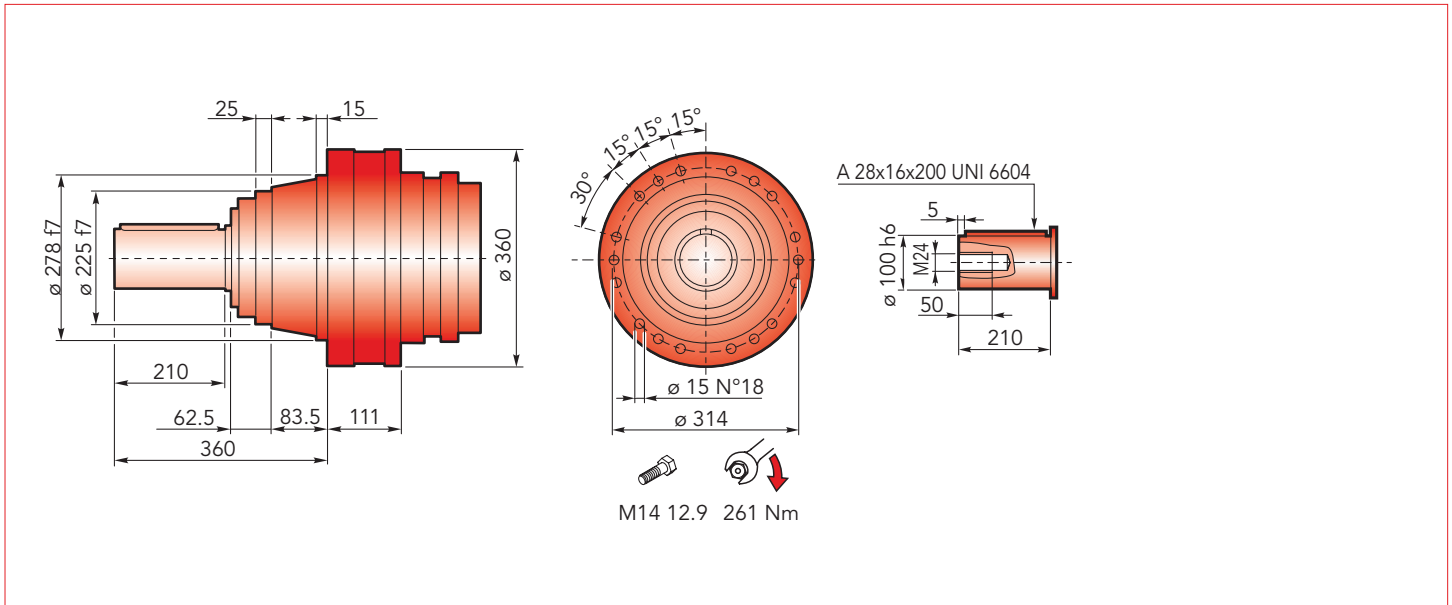

## CHPL 18000 CMC - Flange motori IEC

## CHPL 18000 CMC- IEC Motor flanges

CHPL	IEC 63			IEC 71			IEC 80			IEC 90			IEC 100		
	LP	P	ØD	LP	P	ØD	LP	P	ØD	LP	P	ØD	LP	P	ØD
18002	-	-	-	-	-	-	-	-	-	-	-	-	-	-	-
18003	336.5	36	140	336.5	36	160	356.5	56	200	356.5	56	200	366.5	66	250
18004	380.5	-	-	380.5	-	-	400.5	-	-	400.5	-	-	410.5	-	-

CHPL	IEC 112			IEC 132			IEC 160			IEC 180		
	LP	P	ØD	LP	P	ØD	LP	P	ØD	LP	P	ØD
18002	-	-	-	-	-	-	359	118	350	359	118	350
18003	366.5	66	250	400.5	100	300	439.5	139	-	-	-	-
18004	410.5	-	-	444.5	-	-	483.5	-	-	-	-	-

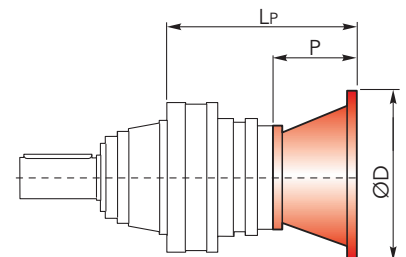

## CHPL 18000 CMC - Alberi maschi entrata

## CHPL 18000 CMC - Male input shafts

CHPL	CM42				CM65				CP65			
	LT	T	LE	ØE	LT	T	LE	ØE	LT	T	LE	ØE
18002	-	-	-	-	362.5	121.5	105	65 h6	394	153	105	65 h6
18003	393.5	93	82	42 h6	435.5	-	-	-	467	-	-	-
18004	437.5	-	-	-	-	-	-	-	-	-	-	-

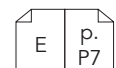
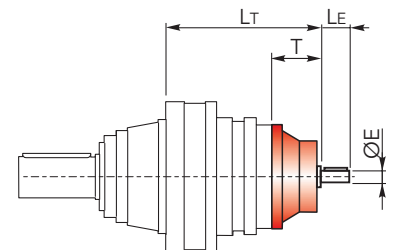



## DIMENSIONI CMC

## CMC DIMENSIONS

CHPL/CHPLB 18000

CHPL 18000 CMC - Riduttore a vite senza fine CHM in entrata CHPL 18000 CMC - CHM input worm gearboxes

CHPL	CHM 50					CHM 63					CHM 75				
	Lv	I	H	M	N	Lv	I	H	M	N	Lv	I	H	M	N
18002	-					-					-				
18003	426	50	110	60	80	435.5	63	135	72	95	414.5	75	161	86	112.5
18004	470					479.5					458.5				

CHPL	CHM 90					CHM 110					CHM 130					
	Lv	I	H	M	N	Lv	I	H	M	N	Lv	I	H	M	N	
18002	-					379	110	237.5	127.5	160	386	130	277.5	147.5	180	
18003	424.5	90	193	103	129.5	452					459					
18004	468.5															

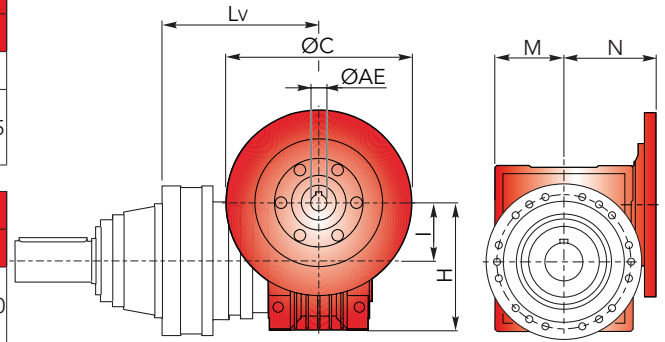

## CHPLB 18000 CMC - Flange motori IEC

## CHPLB 18000 CMC - IEC Motor flanges

CHPLB	IEC 63				IEC 71				IEC 80				IEC 90			
	L	LP	P	ØD	L	LP	P	ØD	L	LP	P	ØD	L	LP	P	ØD
18002	-				-				-				-			
18003	333	276	36	140	333	276	36	160	333	296	56	200	333	296	56	200
18004	406				406				406				406			

CHPLB	IEC 100				IEC 112				IEC 132				IEC 160				IEC 180				
	L	LP	P	ØD	L	LP	P	ØD	L	LP	P	ØD	L	LP	P	ØD	L	LP	P	ØD	
18002	-				-				-				276	433	118		276	433	118	350	
18003	333	306	66	250	333	306	66	250	333	340	100	300	333	379	139	350					
18004	406				406				406				406								

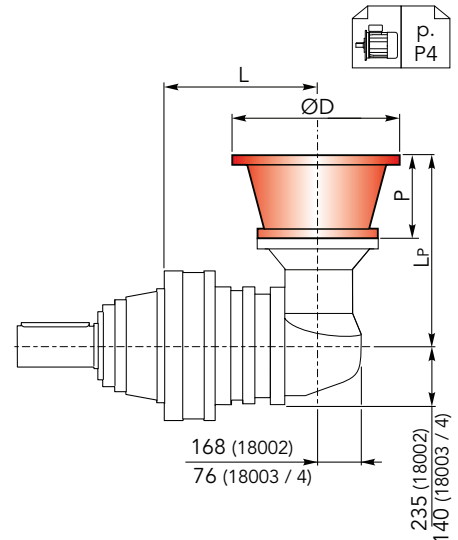

## CHPLB 18000 CMC - Alberi maschi entrata

## CHPL 18000 CMC - Male input shafts

CHPLB	CM42					CM65					CP65					
	L	Lt	T	LE	ØE	L	Lt	T	LE	ØE	L	Lt	T	LE	ØE	
18002	-					276	436.5				276	468				
18003	333	333	93	82	42 h6	333	377.5	121.5	105	65 h6	333	409	153	105	65 h6	
18004	406					406					406					

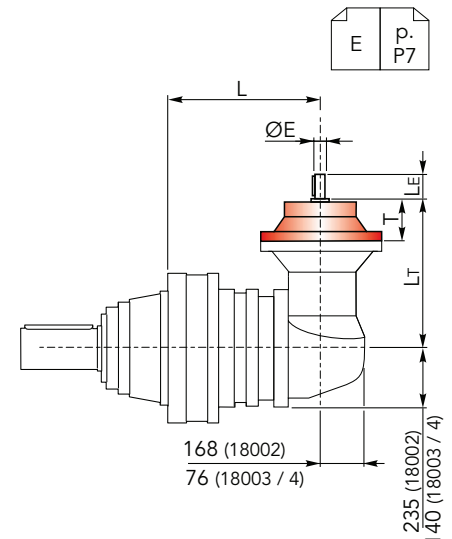



## DIMENSIONI CPS

## CPS DIMENSIONS

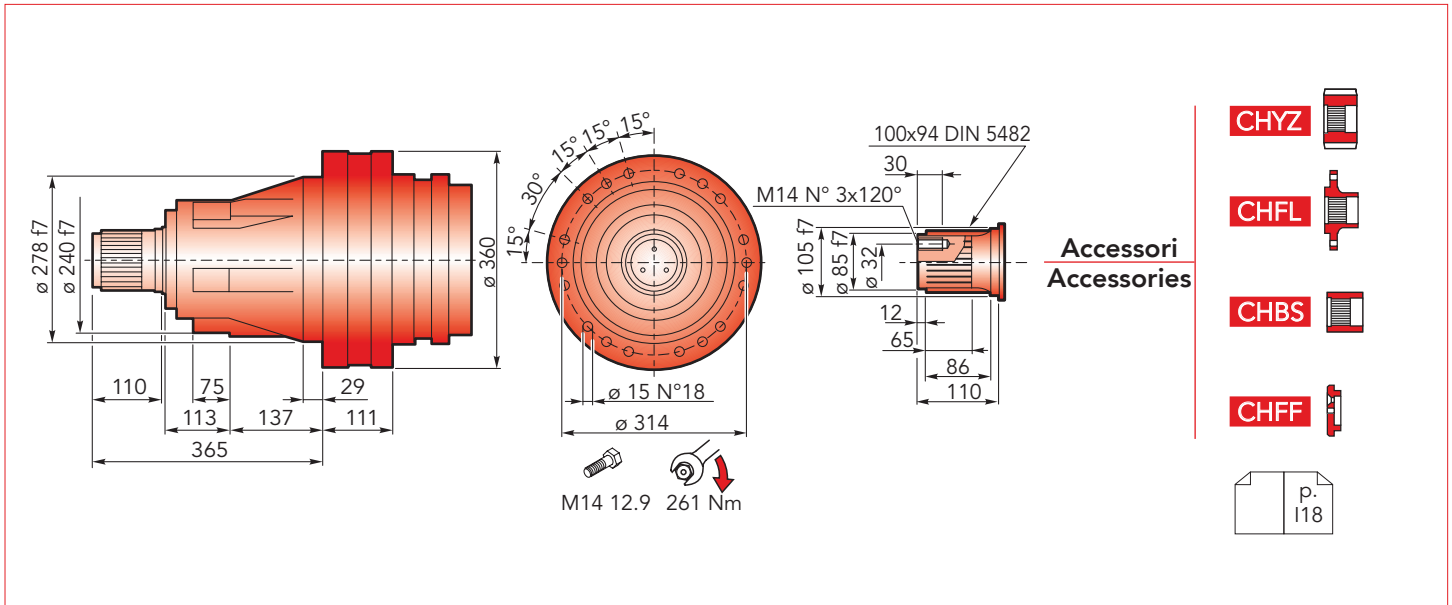

## CHPL 18000 CPS - Flange motori IEC

## CHPL 18000 CPS- IEC Motor flanges

CHPL	IEC 63			IEC 71			IEC 80			IEC 90			IEC 100		
	Lp	P	ØD	Lp	P	ØD	Lp	P	ØD	Lp	P	ØD	Lp	P	ØD
18002	-	-	-	-	-	-	-	-	-	-	-	-	-	-	-
18003	336.5	36	140	336.5	36	160	356.5	56	200	356.5	56	200	366.5	66	250
18004	380.5	-	-	380.5	-	-	400.5	-	-	400.5	-	-	410.5	-	-

CHPL	IEC 112			IEC 132			IEC 160			IEC 180		
	Lp	P	ØD	Lp	P	ØD	Lp	P	ØD	Lp	P	ØD
18002	-	-	-	-	-	-	359	118	350	359	118	350
18003	366.5	66	250	400.5	100	300	439.5	139	-	-	-	-
18004	410.5	-	-	444.5	-	-	483.5	-	-	-	-	-

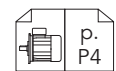
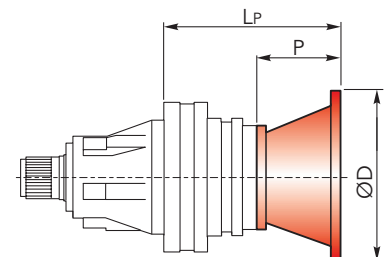

## CHPL 18000 CPS - Alberi maschi entrata

## CHPL 18000 CPS - Male input shafts

CHPL	CM42				CM65				CP65			
	Lt	T	Le	ØE	Lt	T	Le	ØE	Lt	T	Le	ØE
18002	-	-	-	-	362.5	121.5	105	65 h6	394	153	105	65 h6
18003	393.5	93	82	42 h6	435.5	-	-	-	467	-	-	-
18004	437.5	-	-	-	-	-	-	-	-	-	-	-

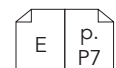
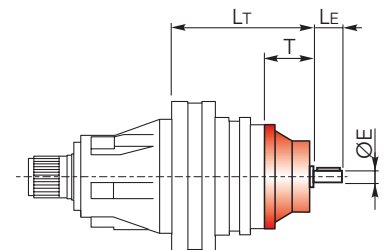



## DIMENSIONI CPS

## CPS DIMENSIONS

CHPL/CHPLB 18000

CHPL 18000 CPS - Riduttore a vite senza fine CHM in entrata

CHPL 18000 CPS - CHM input worm gearboxes

CHPL	CHM 50					CHM 63					CHM 75				
	Lv	I	H	M	N	Lv	I	H	M	N	Lv	I	H	M	N
18002	-					-					-				
18003	426	50	110	60	80	435.5	63	135	72	95	414.5	75	161	86	112.5
18004	470					479.5					458.5				

CHPL	CHM 90					CHM 110					CHM 130				
	Lv	I	H	M	N	Lv	I	H	M	N	Lv	I	H	M	N
18002	-					379	110	237.5	127.5	160	386	130	277.5	147.5	180
18003	424.5	90	193	103	129.5	452					459				
18004	468.5														

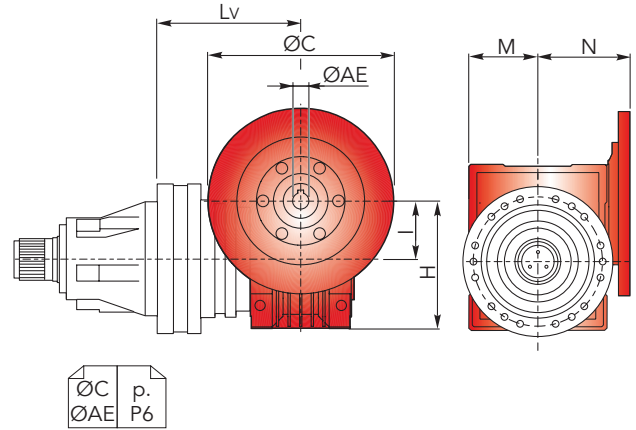

$\begin{matrix} \square & \square \\ \text{ØC} & \text{p.} \\ \text{ØAE} & \text{P6} \end{matrix}$

CHPLB 18000 CPS - Flange motori IEC

CHPLB 18000 CPS - IEC Motor flanges

CHPLB	IEC 63				IEC 71				IEC 80				IEC 90			
	L	Lp	P	ØD	L	Lp	P	ØD	L	Lp	P	ØD	L	Lp	P	ØD
18002	-				-				-				-			
18003	333	276	36	140	333	276	36	160	333	296	56	200	333	296	56	200
18004	406				406				406				406			

CHPLB	IEC 100				IEC 112				IEC 132				IEC 160				IEC 180			
	L	Lp	P	ØD	L	Lp	P	ØD	L	Lp	P	ØD	L	Lp	P	ØD	L	Lp	P	ØD
18002	-				-				-				276	433	118		276	433	118	350
18003	333	306	66	250	333	306	66	250	333	340	100	300	333	379	139		350			
18004	406				406				406				406							

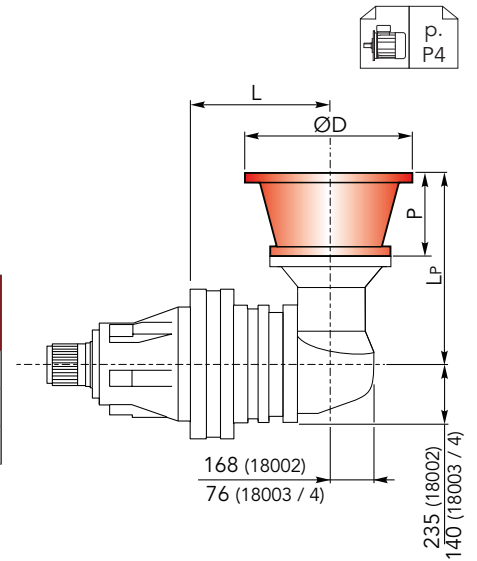

$\begin{matrix} \square & \square \\ \text{p.} \\ \text{P4} \end{matrix}$

CHPLB 18000 CPS - Alberi maschi entrata

CHPL 18000 CPS - Male input shafts

CHPLB	CM42					CM65					CP65				
	L	Lt	T	Le	ØE	L	Lt	T	Le	ØE	L	Lt	T	Le	ØE
18002	-					276	436.5				276	468			
18003	333	333	93	82	42 h6	333	377.5	121.5	105	65 h6	333	409	153	105	65 h6
18004	406					406					406				

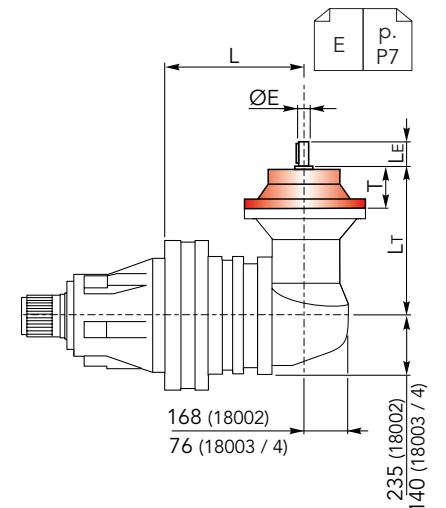

$\begin{matrix} \square & \square \\ \text{E} & \text{p.} \\ \text{P7} \end{matrix}$



## DIMENSIONI CPC

## CPC DIMENSIONS

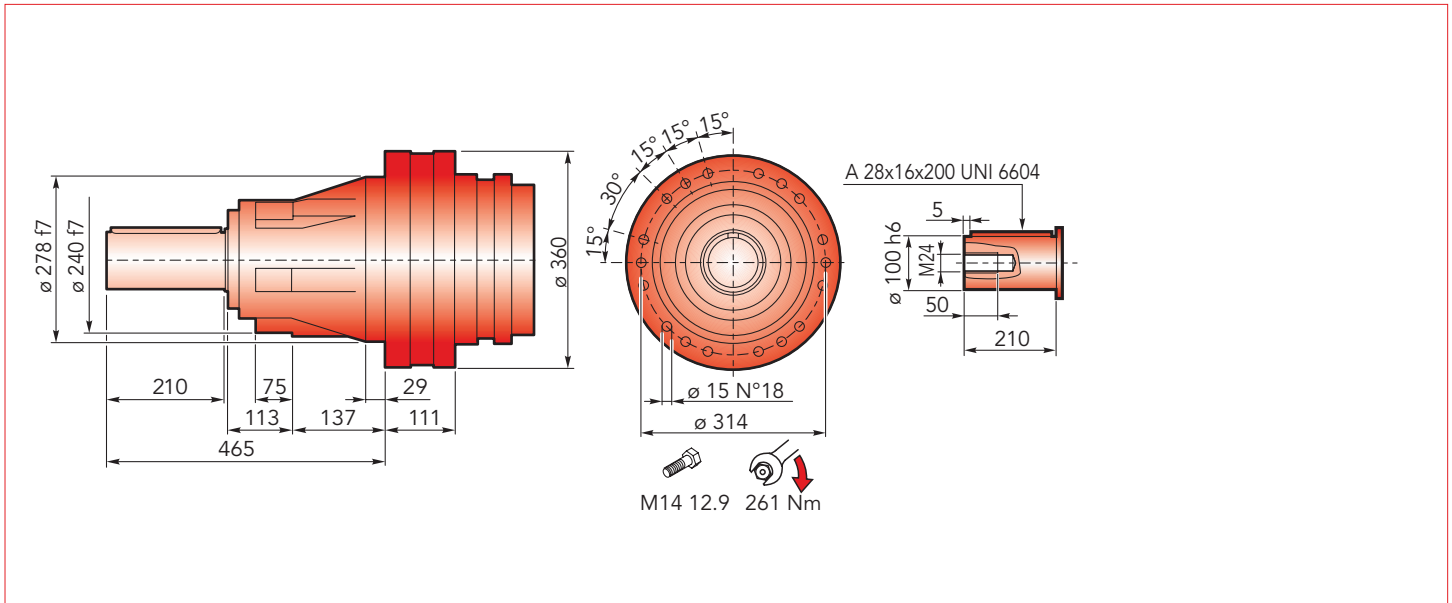

## CHPL 18000 CPC - Flange motori IEC

## CHPL 18000 CPC- IEC Motor flanges

CHPL	IEC 63			IEC 71			IEC 80			IEC 90			IEC 100		
	LP	P	ØD	LP	P	ØD	LP	P	ØD	LP	P	ØD	LP	P	ØD
18002	-	-	-	-	-	-	-	-	-	-	-	-	-	-	-
18003	336.5	36	140	336.5	36	160	356.5	56	200	356.5	56	200	366.5	66	250
18004	380.5	-	-	380.5	-	-	400.5	-	-	400.5	-	-	410.5	-	-

CHPL	IEC 112			IEC 132			IEC 160			IEC 180		
	LP	P	ØD	LP	P	ØD	LP	P	ØD	LP	P	ØD
18002	-	-	-	-	-	-	359	118	350	359	118	350
18003	366.5	66	250	400.5	100	300	439.5	139	-	-	-	-
18004	410.5	-	-	444.5	-	-	483.5	-	-	-	-	-

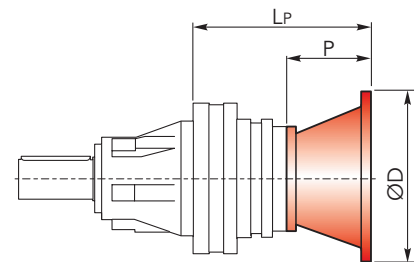

## CHPL 18000 CPC - Alberi maschi entrata

## CHPL 18000 CPC - Male input shafts

CHPL	CM42				CM65				CP65			
	LT	T	LE	ØE	LT	T	LE	ØE	LT	T	LE	ØE
18002	-	-	-	-	362.5	121.5	105	65 h6	394	153	105	65 h6
18003	393.5	93	82	42 h6	435.5	-	-	-	467	-	-	-
18004	437.5	-	-	-	-	-	-	-	-	-	-	-

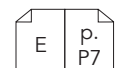
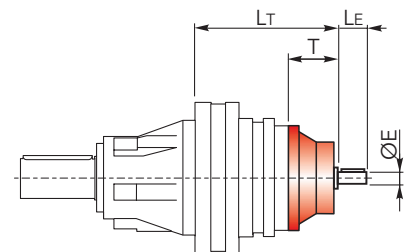





## DIMENSIONI CPC

## CPC DIMENSIONS

CHPL/CHPLB 18000

CHPL 18000 CPC - Riduttore a vite senza fine CHM in entrata

CHPL 18000 CPC - CHM input worm gearboxes

CHPL	CHM 50					CHM 63					CHM 75				
	Lv	I	H	M	N	Lv	I	H	M	N	Lv	I	H	M	N
18002	-					-					-				
18003	426	50	110	60	80	435.5	63	135	72	95	414.5	75	161	86	112.5
18004	470					479.5					458.5				

CHPL	CHM 90					CHM 110					CHM 130				
	Lv	I	H	M	N	Lv	I	H	M	N	Lv	I	H	M	N
18002	-					379	110	237.5	127.5	160	386	130	277.5	147.5	180
18003	424.5	90	193	103	129.5	452					459				
18004	468.5														

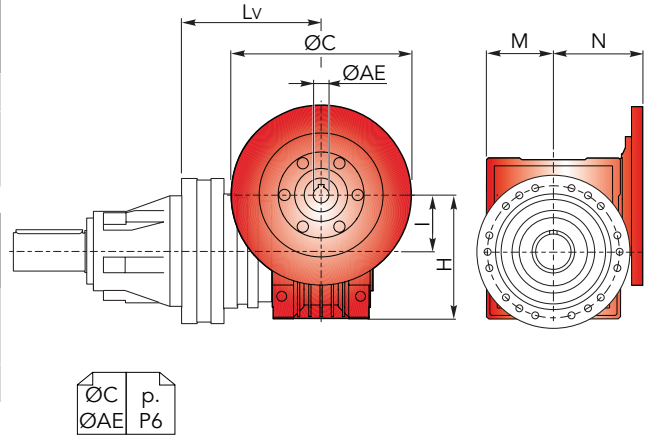

CHPLB 18000 CPC - Flange motori IEC

CHPLB 18000 CPC - IEC Motor flanges

CHPLB	IEC 63				IEC 71				IEC 80				IEC 90			
	L	LP	P	ØD	L	LP	P	ØD	L	LP	P	ØD	L	LP	P	ØD
18002	-				-				-				-			
18003	333	276	36	140	333	276	36	160	333	296	56	200	333	296	56	200
18004	406				406				406				406			

CHPLB	IEC 100				IEC 112				IEC 132				IEC 160				IEC 180			
	L	LP	P	ØD	L	LP	P	ØD	L	LP	P	ØD	L	LP	P	ØD	L	LP	P	ØD
18002	-				-				-				276	433	118		276	433	118	350
18003	333	306	66	250	333	306	66	250	333	340	100	300	333	379	139	350				
18004	406				406				406				406							

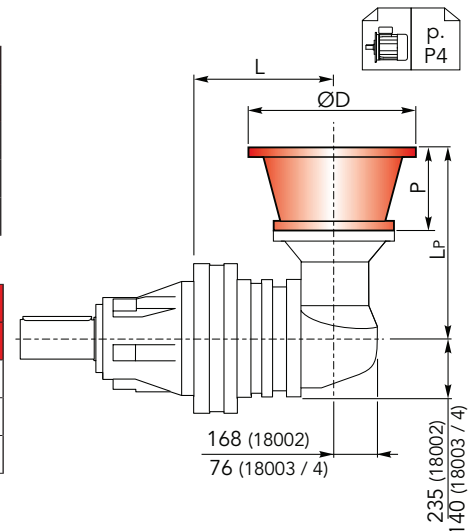

CHPLB 18000 CPC - Alberi maschi entrata

CHPL 18000 CPC - Male input shafts

CHPLB	CM42					CM65					CP65				
	L	Lt	T	LE	ØE	L	Lt	T	LE	ØE	L	Lt	T	LE	ØE
18002	-					276	436.5				276	468			
18003	333	333	93	82	42 h6	333	377.5	121.5	105	65 h6	333	409	153	105	65 h6
18004	406					406					406				

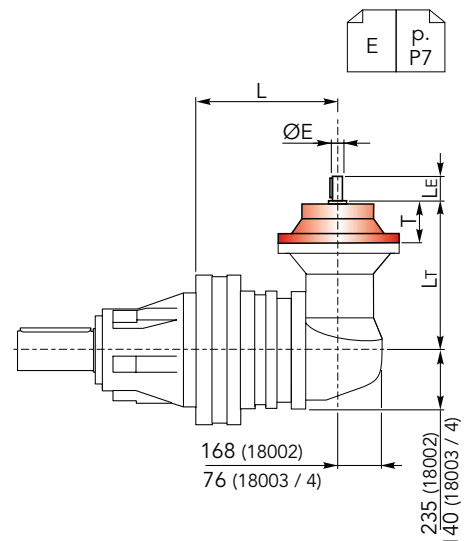



## DIMENSIONI CF

## CF DIMENSIONS

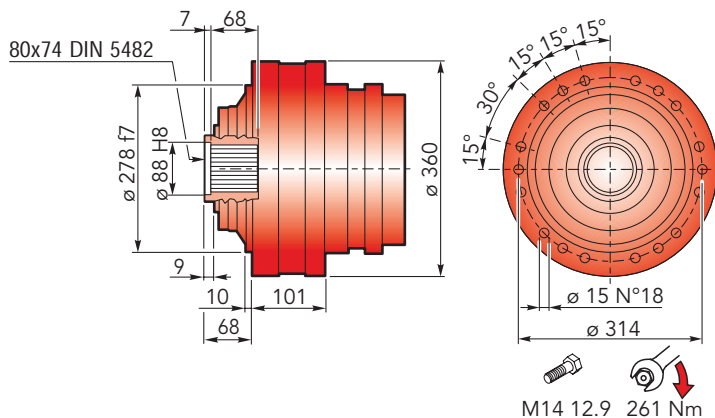

Accessori  
Accessories

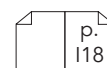

### CHPL 18000 CF - Flange motori IEC

### CHPL 18000 CF- IEC Motor flanges

CHPL	IEC 63			IEC 71			IEC 80			IEC 90			IEC 100		
	LP	P	ØD	LP	P	ØD	LP	P	ØD	LP	P	ØD	LP	P	ØD
18002	-	-	-	-	-	-	-	-	-	-	-	-	-	-	-
18003	326.5	36	140	326.5	36	160	346.5	56	200	346.5	56	200	356.5	66	250
18004	370.5	-	-	370.5	-	-	390.5	-	-	390.5	-	-	400.5	-	-

CHPL	IEC 112			IEC 132			IEC 160			IEC 180		
	LP	P	ØD	LP	P	ØD	LP	P	ØD	LP	P	ØD
18002	-	-	-	-	-	-	349	118	350	349	118	350
18003	356.5	66	250	390.5	100	300	429.5	139	-	-	-	-
18004	400.5	-	-	434.5	-	-	473.5	-	-	-	-	-

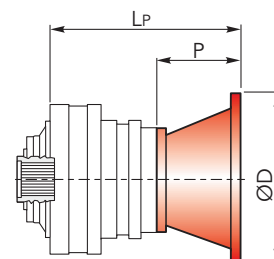

### CHPL 18000 CF - Alberi maschi entrata

### CHPL 18000 CF - Male input shafts

CHPL	CM42				CM65				CP65			
	LT	T	LE	ØE	LT	T	LE	ØE	LT	T	LE	ØE
18002	-	-	-	-	352.5	121.5	105	65 h6	384	153	105	65 h6
18003	383.5	93	82	42 h6	425.5	-	-	-	457	-	-	-
18004	427.5	-	-	-	-	-	-	-	-	-	-	-

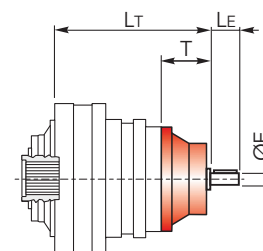



## DIMENSIONI CF

## CF DIMENSIONS

CHPL/CHPLB 18000

CHPL 18000 CF - Riduttore a vite senza fine CHM in entrata

CHPL 18000 CF - CHM input worm gearboxes

CHPL	CHM 50					CHM 63					CHM 75				
	Lv	I	H	M	N	Lv	I	H	M	N	Lv	I	H	M	N
18002	-					-					-				
18003	416	50	110	60	80	425.5	63	135	72	95	404.5	75	161	86	112.5
18004	460					469.5					448.5				

CHPL	CHM 90					CHM 110					CHM 130				
	Lv	I	H	M	N	Lv	I	H	M	N	Lv	I	H	M	N
18002	-					369	110	237.5	127.5	160	376	130	277.5	147.5	180
18003	414.5	90	193	103	129.5	442					449				
18004	458.5					-					-				

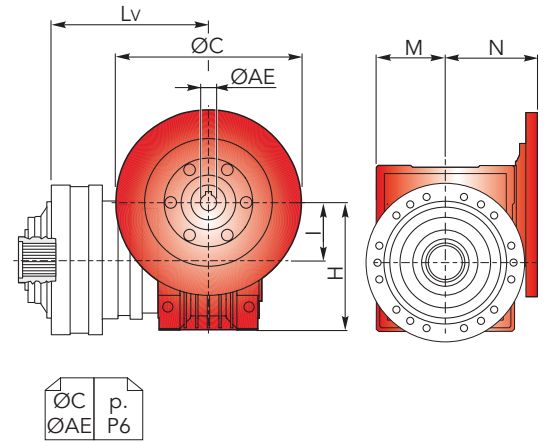

CHPLB 18000 CF - Flange motori IEC

CHPLB 18000 CF - IEC Motor flanges

CHPLB	IEC 63				IEC 71				IEC 80				IEC 90			
	L	Lp	P	ØD	L	Lp	P	ØD	L	Lp	P	ØD	L	Lp	P	ØD
18002	-				-				-				-			
18003	323	276	36	140	323	276	36	160	323	296	56	200	323	296	56	200
18004	396				396				396				396			

CHPLB	IEC 100				IEC 112				IEC 132				IEC 160				IEC 180			
	L	Lp	P	ØD	L	Lp	P	ØD	L	Lp	P	ØD	L	Lp	P	ØD	L	Lp	P	ØD
18002	-				-				-				266	433	118	350	266	433	118	350
18003	323	306	66	250	323	306	66	250	323	340	100	300	323	379	139	350	-			
18004	396				396				396				396				-			

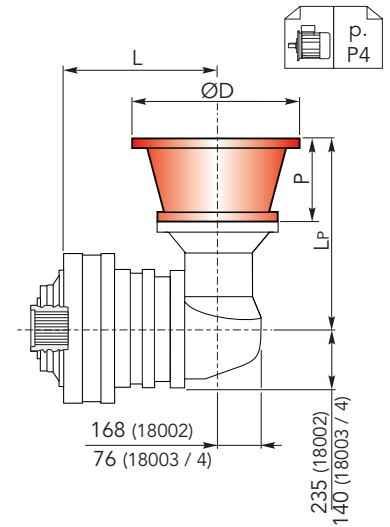

CHPLB 18000 CF - Alberi maschi entrata

CHPL 18000 CF - Male input shafts

CHPLB	CM42					CM65					CP65				
	L	Lt	T	Le	ØE	L	Lt	T	Le	ØE	L	Lt	T	Le	ØE
18002	-					266	436.5				266	468			
18003	323	333	93	82	42 h6	323	377.5	121.5	105	65 h6	323	409	153	105	65 h6
18004	396					396					396				

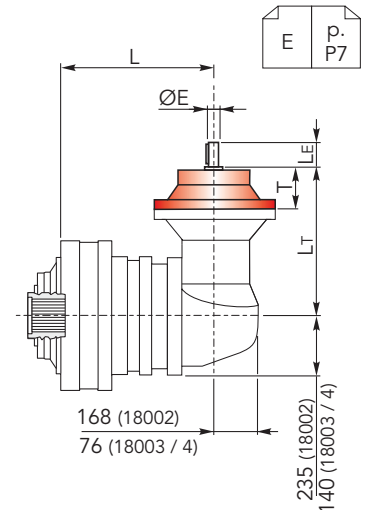



## DIMENSIONI CFS

## CFS DIMENSIONS

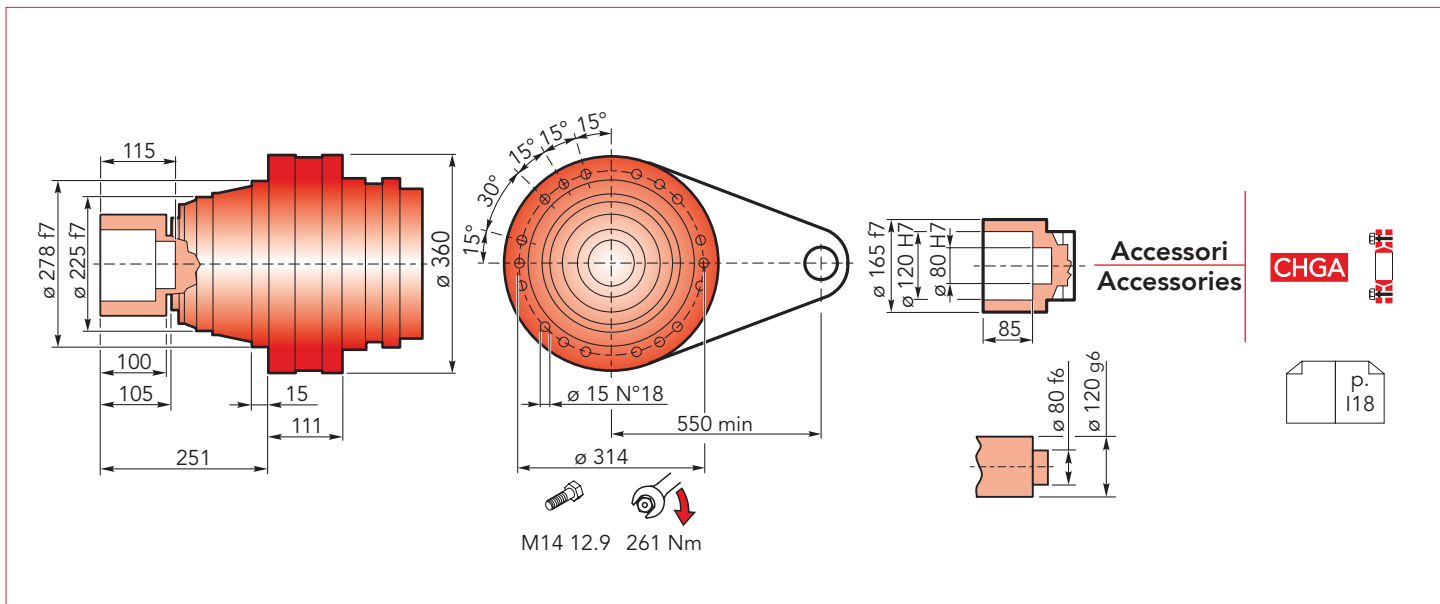

### CHPL 18000 CFS - Flange motori IEC

### CHPL 18000 CFS- IEC Motor flanges

CHPL	IEC 63			IEC 71			IEC 80			IEC 90			IEC 100		
	LP	P	ØD	LP	P	ØD	LP	P	ØD	LP	P	ØD	LP	P	ØD
18002	-	-	-	-	-	-	-	-	-	-	-	-	-	-	-
18003	336.5	36	140	336.5	36	160	356.5	56	200	356.5	56	200	366.5	66	250
18004	380.5	-	-	380.5	-	-	400.5	-	-	400.5	-	-	410.5	-	-

CHPL	IEC 112			IEC 132			IEC 160			IEC 180		
	LP	P	ØD	LP	P	ØD	LP	P	ØD	LP	P	ØD
18002	-	-	-	-	-	-	359	118	350	359	118	350
18003	366.5	66	250	400.5	100	300	439.5	139	-	-	-	-
18004	410.5	-	-	444.5	-	-	483.5	-	-	-	-	-

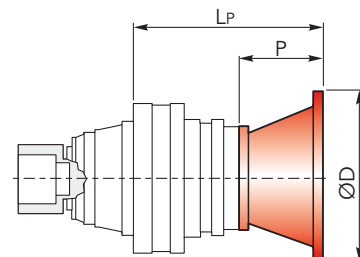

### CHPL 18000 CFS - Alberi maschi entrata

### CHPL 18000 CFS - Male input shafts

CHPL	CM42				CM65				CP65			
	LT	T	LE	ØE	LT	T	LE	ØE	LT	T	LE	ØE
18002	-	-	-	-	362.5	121.5	105	65 h6	394	153	105	65 h6
18003	393.5	93	82	42 h6	435.5	-	-	-	467	-	-	-
18004	437.5	-	-	-	-	-	-	-	-	-	-	-

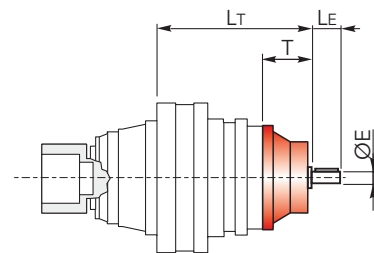



## DIMENSIONI CFS

## CFS DIMENSIONS

CHPL/CHPLB 18000

CHPL 18000 CFS - Riduttore a vite senza fine CHM in entrata CHPL 18000 CFS - CHM input worm gearboxes

CHPL	CHM 50					CHM 63					CHM 75				
	Lv	I	H	M	N	Lv	I	H	M	N	Lv	I	H	M	N
18002	-					-					-				
18003	426	50	110	60	80	435.5	63	135	72	95	414.5	75	161	86	112.5
18004	470					479.5					458.5				

CHPL	CHM 90					CHM 110					CHM 130				
	Lv	I	H	M	N	Lv	I	H	M	N	Lv	I	H	M	N
18002	-					379	110	237.5	127.5	160	386	130	277.5	147.5	180
18003	424.5	90	193	103	129.5	452					459				
18004	468.5					-					-				

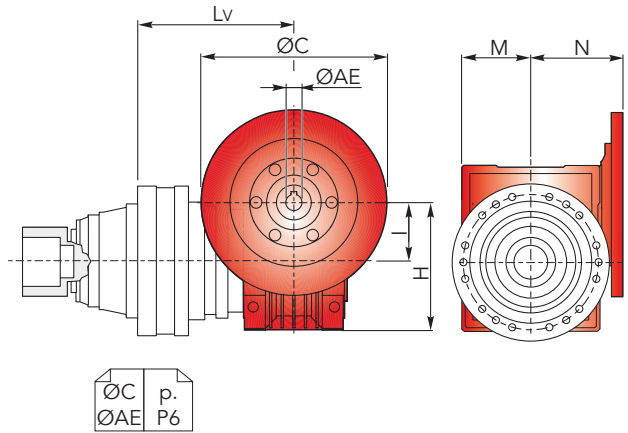

## CHPLB 18000 CFS - Flange motori IEC

## CHPLB 18000 CFS - IEC Motor flanges

CHPLB	IEC 63				IEC 71				IEC 80				IEC 90			
	L	LP	P	ØD	L	LP	P	ØD	L	LP	P	ØD	L	LP	P	ØD
18002	-				-				-				-			
18003	333	276	36	140	333	276	36	160	333	296	56	200	333	296	56	200
18004	406				406				406				406			

CHPLB	IEC 100				IEC 112				IEC 132				IEC 160				IEC 180			
	L	LP	P	ØD	L	LP	P	ØD	L	LP	P	ØD	L	LP	P	ØD	L	LP	P	ØD
18002	-				-				-				276	433	118		276	433	118	350
18003	333	306	66	250	333	306	66	250	333	340	100	300	333	379	139	350	-			
18004	406				406				406				406				-			

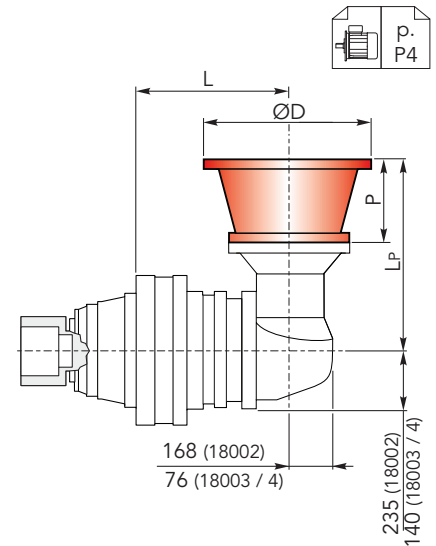

## CHPLB 18000 CFS - Alberi maschi entrata

## CHPL 18000 CFS - Male input shafts

CHPLB	CM42					CM65					CP65				
	L	Lt	T	Le	ØE	L	Lt	T	Le	ØE	L	Lt	T	Le	ØE
18002	-					276	436.5				276	468			
18003	333	333	93	82	42 h6	333	377.5	121.5	105	65 h6	333	409	153	105	65 h6
18004	406					406					406				

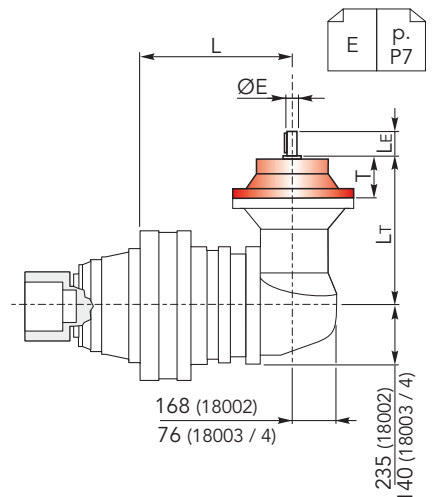



## DIMENSIONI CCPC

## CCPC DIMENSIONS

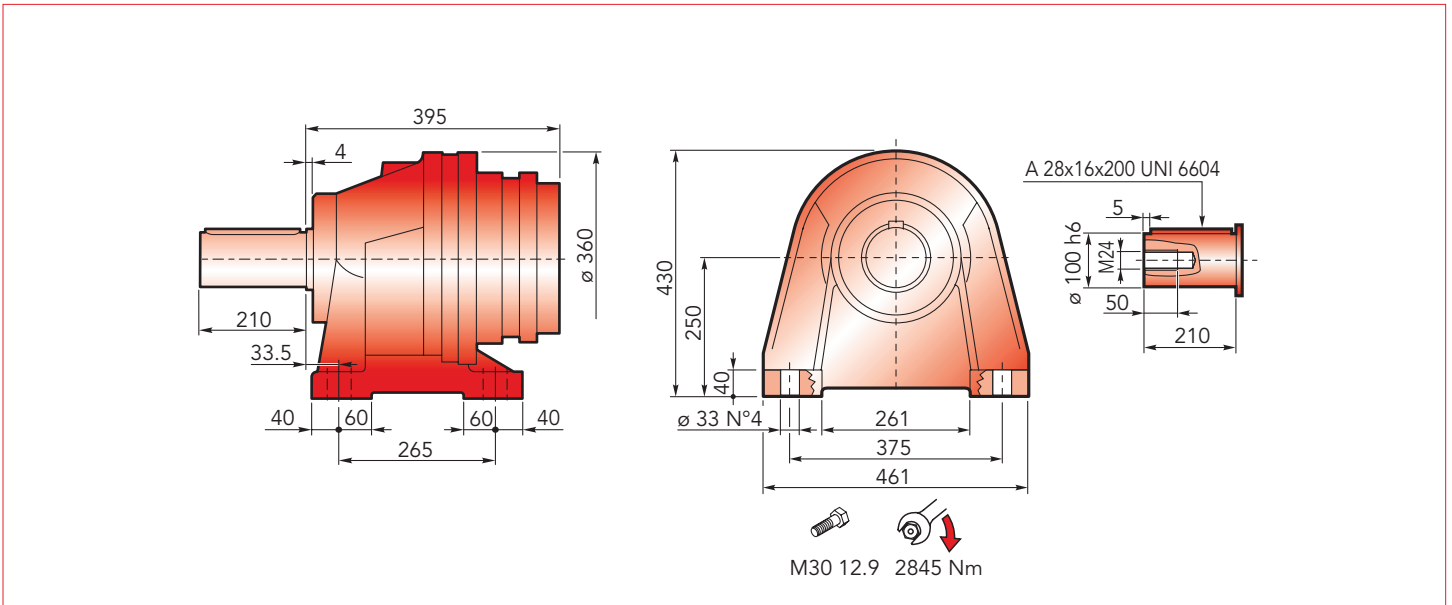

### CHPL 18000 CCPC - Flange motori IEC

### CHPL 18000 CCPC- IEC Motor flanges

CHPL	IEC 63			IEC 71			IEC 80			IEC 90			IEC 100		
	LP	P	ØD	LP	P	ØD	LP	P	ØD	LP	P	ØD	LP	P	ØD
18002	-	-	-	-	-	-	-	-	-	-	-	-	-	-	-
18003	490.5	36	140	490.5	36	160	510.5	56	200	510.5	56	200	520.5	66	250
18004	538.5	-	-	538.5	-	-	558.5	-	-	558.5	-	-	568.5	-	-

CHPL	IEC 112			IEC 132			IEC 160			IEC 180		
	LP	P	ØD	LP	P	ØD	LP	P	ØD	LP	P	ØD
18002	-	-	-	-	-	-	513	118	350	513	118	350
18003	520.5	66	250	554.5	100	300	593.5	139	-	-	-	-
18004	568.5	-	-	602.5	-	-	641.5	-	-	-	-	-

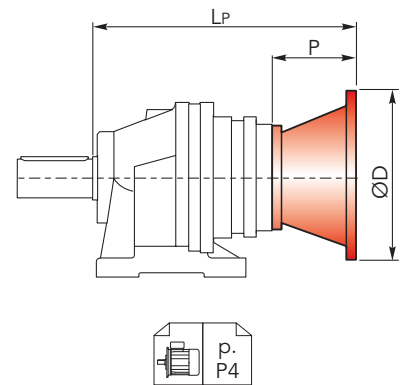

### CHPL 18000 CCPC - Alberi maschi entrata

### CHPL 18000 CCPC - Male input shafts

CHPL	CM42				CM65				CP65			
	LT	T	LE	ØE	LT	T	LE	ØE	LT	T	LE	ØE
18002	-	-	-	-	516.5	121.5	105	65 h6	548	153	105	65 h6
18003	547.5	93	82	42 h6	589.5	-	-	-	621	-	-	-
18004	595.5	-	-	-	-	-	-	-	-	-	-	-

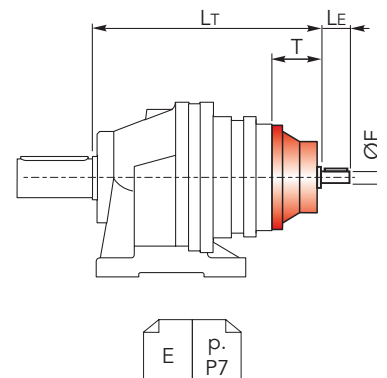



## DIMENSIONI CCPC

## CCPC DIMENSIONS

CHPL/CHPLB 18000

CHPL 18000 CCPC - Riduttore a vite senza fine CHM in entrata CHPL 18000 CCPC - CHM input worm gearboxes

CHPL	CHM 50					CHM 63					CHM 75				
	Lv	I	H	M	N	Lv	I	H	M	N	Lv	I	H	M	N
18002	-					-					-				
18003	580					589.5					568.5				
18004	628	50	110	60	80	637.5	63	135	72	95	616.5	75	161	86	112.5

CHPL	CHM 90					CHM 110					CHM 130					
	Lv	I	H	M	N	Lv	I	H	M	N	Lv	I	H	M	N	
18002	-					533					540					
18003	578.5					606	110	237.5	127.5	160	613	130	277.5	147.5	180	
18004	626.5	90	193	103	129.5	-					-					

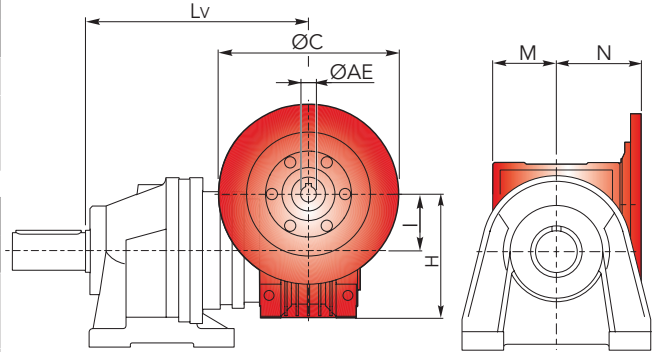

## CHPLB 18000 CCPC - Flange motori IEC

## CHPLB 18000 CCPC - IEC Motor flanges

CHPLB	IEC 63				IEC 71				IEC 80				IEC 90			
	L	LP	P	ØD	L	LP	P	ØD	L	LP	P	ØD	L	LP	P	ØD
18002	-				-				-				-			
18003	483				483				483				483			
18004	542.5	276	36	140	542.5	276	36	160	542.5	296	56	200	542.5	296	56	200

CHPLB	IEC 100				IEC 112				IEC 132				IEC 160				IEC 180					
	L	LP	P	ØD	L	LP	P	ØD	L	LP	P	ØD	L	LP	P	ØD	L	LP	P	ØD		
18002	-				-				-				430	433	118		430	433	118	350		
18003	483				483				483				483				483					
18004	542.5	306	66	250	542.5	306	66	250	542.5	340	100	300	542.5	379	139							

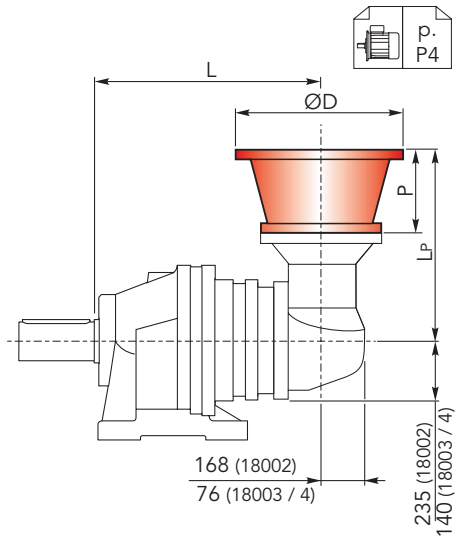

## CHPLB 18000 CCPC - Alberi maschi entrata

## CHPL 18000 CCPC - Male input shafts

CHPLB	CM42					CM65					CP65					
	L	Lt	T	Le	ØE	L	Lt	T	Le	ØE	L	Lt	T	Le	ØE	
18002	-					430	436.5				430	468				
18003	483					483		121.5	105	65 h6	483		153	105	65 h6	
18004	542.5	333	93	82	42 h6	542.5	377.5				542.5	409				

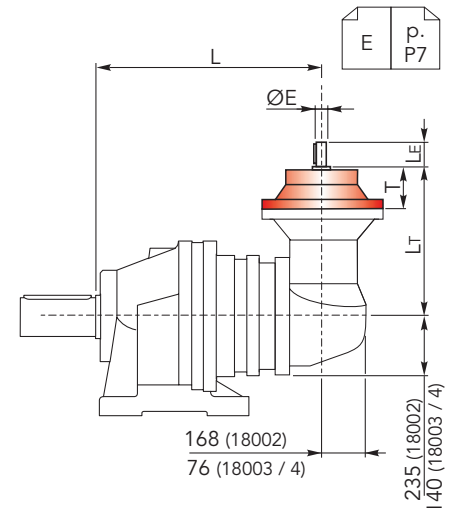



## ACCESSORI

## ACCESSORIES

CHYZ



## Pignoni / Pinions

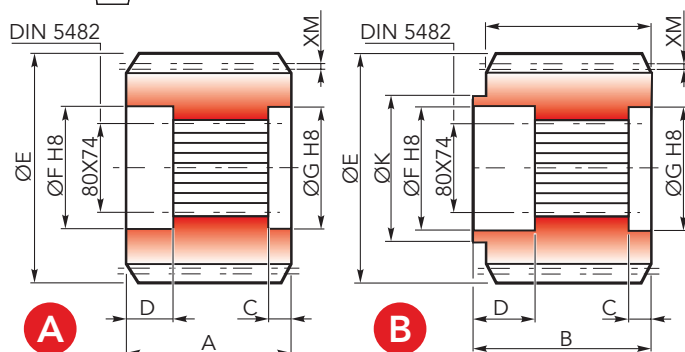

	Uscita / Output	M	Z	XM	A	B	C	D	E	F	G	K	Codice / Code
A	CMS	10	12	0	90	-	10	31	140	85	80	-	1071.236.042
	CMS	10	14	0	90	-	10	31	160	85	80	-	1071.238.042
	CMS	10	15	5	90	-	10	31	180	85	80	-	1071.138.042
B	CMS	10	18	5	85	114	31	24	209.3	85	95	160	1071.261.042
	CMS	12	14	3	90	105	15	31	194.5	85	95	130	1071.269.042

CHFF



## Fondello di arresto / Stop bottom plate

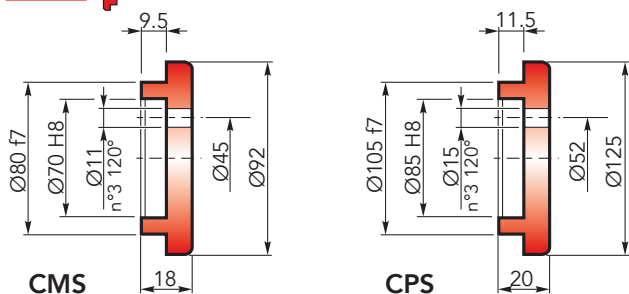

CMS

Codice / Code:  
1075.030.000

CPS

Codice / Code:  
1075.042.000

CHBS



## Boccola scanalata / Splined bushing

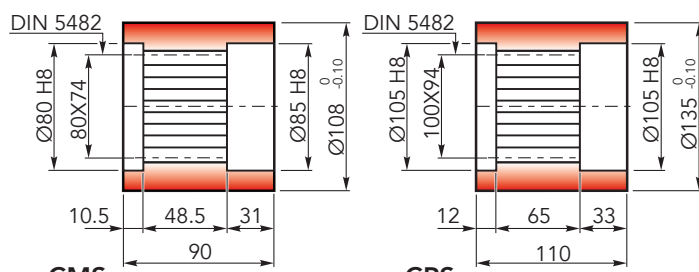

CMS

Codice / Code:  
6171.103.076

CPS

Codice / Code:  
8171.112.041

CHKB

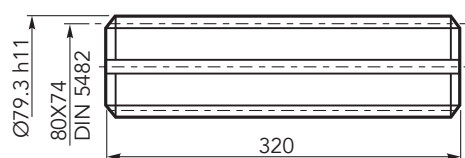

## Barra scanalata / Splined rod

Codice / Code:  
3071.406.042

CHGA

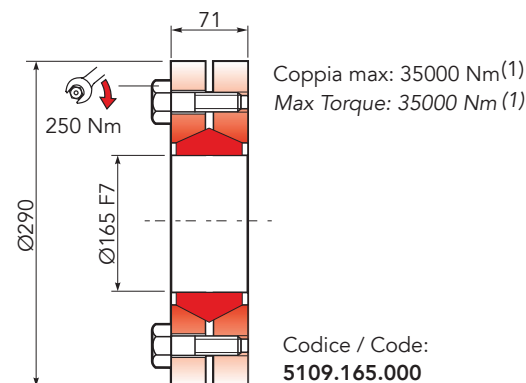

## Giunto di attrito / Shrink disc

Coppia max: 35000 Nm<sup>(1)</sup>  
Max Torque: 35000 Nm<sup>(1)</sup>Codice / Code:  
5109.165.000

(1): Coppia max indicata è valida solo con calettatori forniti da Chiaravalli S.p.A.

(1): The maximum torque indicated is valid only with shrink discs supplied by Chiaravalli S.p.A.

CHFL



## Flangia / Flange

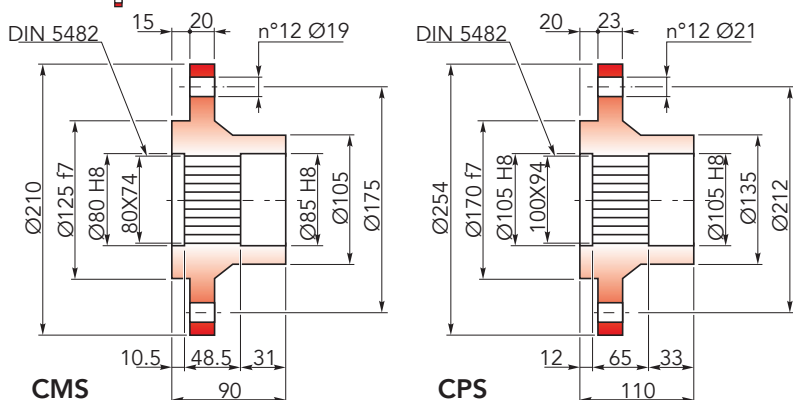

CMS

Codice / Code:  
6171.105.098

CPS

Codice / Code:  
8171.104.098



## CARICHI RADIALI ( $F_r$ )

Nel diagramma seguente, sono indicati i carichi radiali  $F_r$  (N) applicabili sull'albero uscita in funzione della distanza di applicazione  $L$  rispetto alla battuta dell'albero.

## RADIAL LOADS ( $F_r$ )

The hereunder table shows the allowable radial loads  $F_r$  (N) on the output shaft with reference to the distance  $L$ .

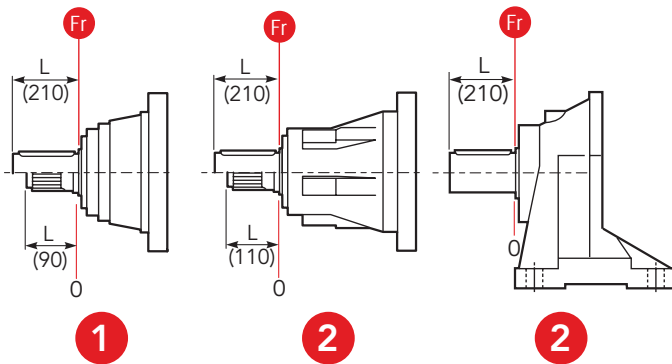
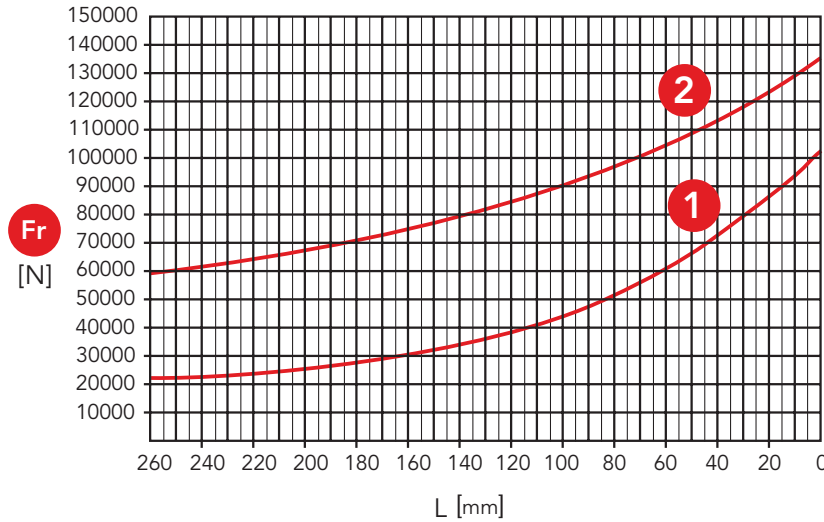

- 1** Uscita / Output: CMS, CMC
- 2** Uscita / Output: CPS, CPC, CCPC

## CARICHI ASSIALI ( $F_a$ )

Nella tabella seguente sono indicati i carichi assiali  $F_a$  (N) applicabili sull'albero di uscita in funzione della direzione di applicazione del carico e della versione.

## AXIAL LOADS ( $F_a$ )

The hereunder table shows the allowable axial loads  $F_a$  (N) on the output shaft with reference to the load direction and the output type.

	<b>1</b>	<b>2</b>	
<b><math>F_a</math></b> [N]	45000	85000	←
	65000	85000	→

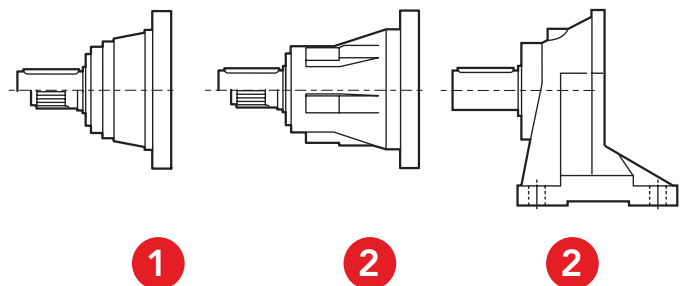



- 1** Uscita / Output: CMS, CMC
- 2** Uscita / Output: CPS, CPC, CCPC



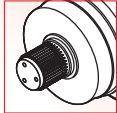
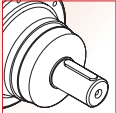
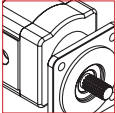
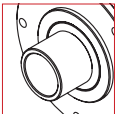
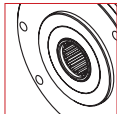
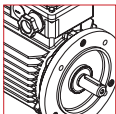
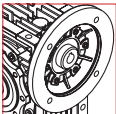
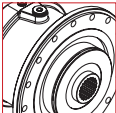

# CHPL/CHPLB 25000

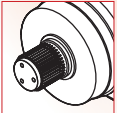
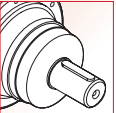
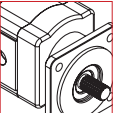
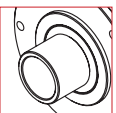
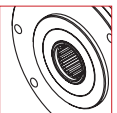
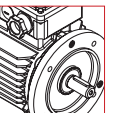
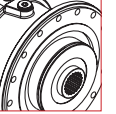

	<b>i</b>	<b>T<sub>2n</sub></b> (daNm)	<b>OUT</b>		<b>IN</b>	
<b>25001</b>	4.00 ÷ 6.25	1339.5 ÷ 2244.9	 Ø110	 100X94 DIN 5482	 Ø42 Ø65	 Hydraulic Motor
<b>25002</b>	14.7 ÷ 43.8	1339.5 ÷ 2244.9	 Ø135	 100X94 DIN 5482	 Electric Motor	 Worm gearboxes
<b>25003</b>	55.4 ÷ 317.2	1339.5 ÷ 2244.9				
<b>25004</b>	338.8 ÷ 1774.0	1339.5 ÷ 2244.9			 Brake	

	<b>i</b>	<b>T<sub>2n</sub></b> (daNm)	<b>OUT</b>		<b>IN</b>	
<b>25002</b>	12.3 ÷ 29.2	1339.5 ÷ 2244.9	 Ø110	 100X94 DIN 5482	 Ø42 Ø65	 Hydraulic Motor
<b>25003</b>	50.7 ÷ 238.2	1339.5 ÷ 2244.9	 Ø135	 100X94 DIN 5482	 Electric Motor	
<b>25004</b>	252.4 ÷ 1726.9	1339.5 ÷ 2244.9			 Brake	

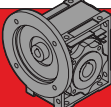

## DATI TECNICI

## TECHNICAL DATA



 CHPL	i	T <sub>2n</sub> (n <sub>1</sub> =1400 rpm) [daNm]	P <sub>1n</sub> (n <sub>1</sub> =1400 rpm) [kW]	P <sub>t</sub> [kW]	IEC (B5)	 CHM	 CM / CP
25001	4	2244.9	823	50	160   180 200   225 250	-	-
	5.2	1735.7	489				
	6.25	1339.5	314				
25002	14.7	2244.9	224	30	160   180 200	CHM 110 CHM 130	CM65 CP65
	17.7	2244.9	186				
	20	2244.9	165				
	23	1735.7	111				
	26	1735.7	98				
	30.2	1735.7	84				
	36.3	1339.5	54				
	43.8	1339.5	45				
	25003	55.4	2244.9				
60.5		2244.9	54				
73.1		2244.9	45				
88		2244.9	37				
95		1735.7	27				
106.3		2244.9	31				
114.4		1735.7	22				
128.4		2244.9	26				
134.3		1735.7	19				
156		1735.7	16				
167		1735.7	15				
188.5		1735.7	13				
218.7		1735.7	12				
226.6		1339.5	8.7				
262.8		1339.5	7.5				
317.2		1339.5	6.2				
25004	338.8	2244.9	9.7	15	63   71 80   90 100   112 132   160	CHM 50 CHM 63 CHM 75 CHM 90	CM42
	374	2244.9	8.8				
	408.4	2244.9	8.1				
	424.3	2244.9	7.8				
	455.5	2244.9	7.2				
	493.2	2244.9	6.7				
	556.9	2244.9	5.9				
	617.8	2244.9	5.3				
	697.5	2244.9	4.7				
	752.3	1734.7	3.4				
	803.1	1734.7	3.2				
	873.6	1734.7	2.9				
	934.9	1734.7	2.7				
	1013.4	1734.7	2.5				
	1126.9	1734.7	2.3				
	1272.4	1734.7	2.0				
1354.5	1339.5	1.4					
1476	1734.7	1.7					
1529.3	1339.5	1.3					
1774	1339.5	1.1					

n<sub>1max</sub> = 2800 rpmSolo per / Only for CHPL25001: n<sub>1max</sub> = 1500 rpm

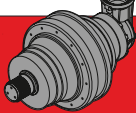

## DATI TECNICI

## TECHNICAL DATA

 CHPLB	i	T <sub>2n</sub> (n <sub>1</sub> =1400 rpm)	P <sub>1n</sub> (n <sub>1</sub> =1400 rpm)	P <sub>t</sub>	IEC	 CM / CP
		[daNm]	[kW]	[kW]	(B5)	
25002	12.3	2244.9	268	30	160   180 200	CM65 CP65
	16	1735.7	159			
	19.2	1339.5	102			
	24.3	1735.7	105			
	29.2	1339.5	67			
25003	50.7	2244.9	65	20	63   71 80   90 100   112 132   160 180	CM42 CM65 CP65
	61.2	2244.9	54			
	69.1	2244.9	48			
	79.6	1735.7	32			
	89.8	1735.7	28			
	96.4	2244.9	34			
	104.2	1735.7	24			
	125.4	1735.7	20			
	141.6	1735.7	18			
	164.2	1735.7	15			
	197.4	1339.5	10			
	238.2	1339.5	8			
	25004	252.4	2244.9			
285		2244.9	12			
304		2244.9	11			
364.3		2244.9	9.0			
397.8		2244.9	8.3			
449.2		2244.9	7.3			
498.3		2244.9	6.6			
562.6		2244.9	5.8			
651.2		1735.7	3.9			
731.4		1735.7	3.5			
789.4		2244.9	4.2			
985.2		1735.7	2.6			
1190.5		1735.7	2.1			
1430.9		1339.5	1.4			
1726.9	1339.5	1.1				

n<sub>1max</sub> = 2800 rpmSolo per / Only for CHPLB 25002: n<sub>1max</sub> = 2000 rpm



## DIMENSIONI CMS

## CMS DIMENSIONS

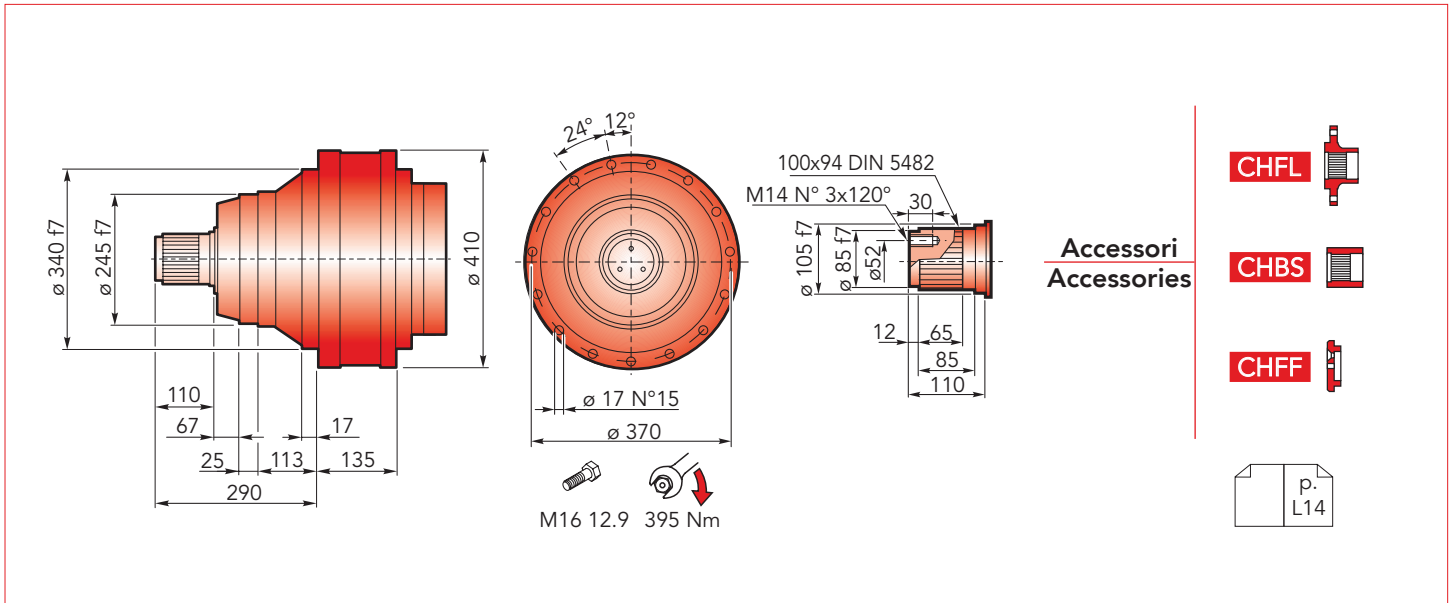

## CHPL 25000 CMS - Flange motori IEC

## CHPL 25000 CMS- IEC Motor flanges

CHPL	IEC 63			IEC 71			IEC 80			IEC 90			IEC 100			IEC 112		
	Lp	P	ØD	Lp	P	ØD	Lp	P	ØD	Lp	P	ØD	Lp	P	ØD	Lp	P	ØD
25001	-	-	-	-	-	-	-	-	-	-	-	-	-	-	-	-	-	-
25002	-	-	-	-	-	-	-	-	-	-	-	-	-	-	-	-	-	-
25003	419.5	36	140	419.5	36	160	439.5	56	200	439.5	56	200	449.5	66	250	449.5	66	250
25004	467.5	36	140	467.5	36	160	487.5	56	200	487.5	56	200	497.5	66	250	497.5	66	250

CHPL	IEC 132			IEC 160			IEC 180			IEC 200			IEC 225			IEC 250		
	Lp	P	ØD	Lp	P	ØD	Lp	P	ØD	Lp	P	ØD	Lp	P	ØD	Lp	P	ØD
25001	-	-	-	380	150	-	380	150	-	380	150	400	369	139	450	369	139	550
25002	-	-	-	442	118	350	442	118	350	472	148	400	-	-	-	-	-	-
25003	483.5	100	300	522.5	139	350	522.5	139	350	-	-	-	-	-	-	-	-	-
25004	531.5	100	300	570.5	139	350	-	-	-	-	-	-	-	-	-	-	-	-

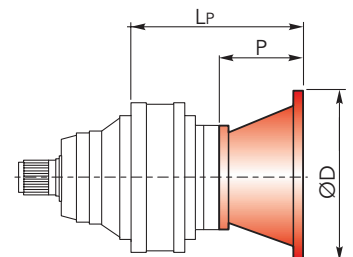

## CHPL 25000 CMS - Alberi maschi entrata

## CHPL 25000 CMS - Male input shafts

CHPL	CM42				CM65				CP65			
	Lt	T	Le	ØE	Lt	T	Le	ØE	Lt	T	Le	ØE
25001	-	-	-	-	-	-	-	-	-	-	-	-
25002	-	-	-	-	445.5	121.5	105	65 h6	477	153	105	65 h6
25003	476.5	93	82	42 h6	518.5	-	-	-	550	-	-	-
25004	524.5	93	82	42 h6	-	-	-	-	-	-	-	-

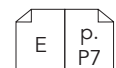
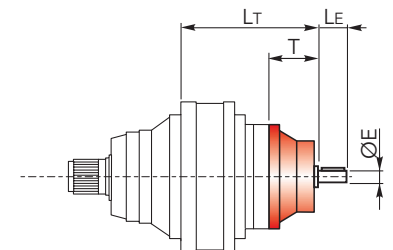



## DIMENSIONI CMS

## CMS DIMENSIONS

CHPL/CHPLB 25000

CHPL 25000 CMS - Riduttore a vite senza fine CHM in entrata

CHPL 25000 CMS - CHM input worm gearboxes

CHPL	CHM 50					CHM 63					CHM 75				
	Lv	I	H	M	N	Lv	I	H	M	N	Lv	I	H	M	N
25001	-					-					-				
25002	-					-					-				
25003	509	50	110	60	80	518.5	63	135	72	95	497.5	75	161	86	112.5
25004	557					566.5					545.5				

CHPL	CHM 90					CHM 110					CHM 130					
	Lv	I	H	M	N	Lv	I	H	M	N	Lv	I	H	M	N	
25001	-					-					-					
25002	-					462					469					
25003	507.5	90	193	103	129.5	535	110	237.5	127.5	160	542	130	277.5	147.5	180	
25004	555.5															

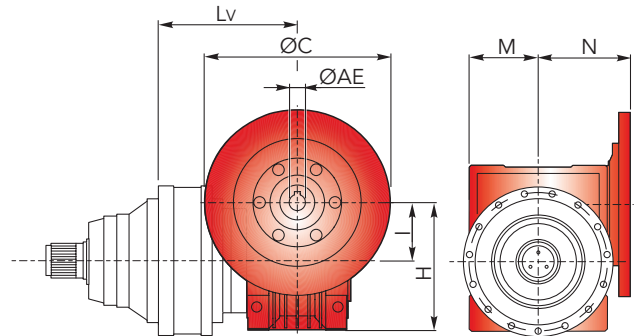

CHPLB 25000 CMS - Flange motori IEC

CHPLB 25000 CMS - IEC Motor flanges

CHPLB	IEC 63				IEC 71				IEC 80				IEC 90				IEC 100			
	L	LP	P	ØD	L	LP	P	ØD	L	LP	P	ØD	L	LP	P	ØD	L	LP	P	ØD
25002	-				-				-				-				-			
25003	410	276	36	140	410	276	36	160	410	296	56	200	410	296	56	200	410	306	66	250
25004	483				483				483				483				483			

CHPLB	IEC 112				IEC 132				IEC 160				IEC 180				IEC 200			
	L	LP	P	ØD	L	LP	P	ØD	L	LP	P	ØD	L	LP	P	ØD	L	LP	P	ØD
25002	-				-				308	433	118		308	433	118		308	463	148	400
25003	410	306	66	250	410	340	100	300	410	379	139	350	410	379	139	350				
25004	483				483				483											

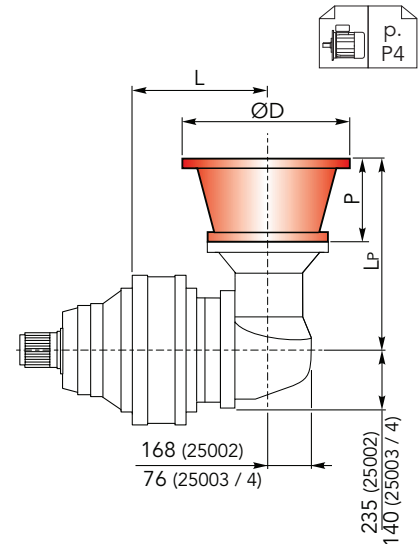

CHPLB 25000 CMS - Alberi maschi entrata

CHPL 25000 CMS - Male input shafts

CHPLB	CM42					CM65					CP65				
	L	Lt	T	Le	ØE	L	Lt	T	Le	ØE	L	Lt	T	Le	ØE
25002	-					308	436.5				308	468			
25003	410	333	93	82	42 h6	410	377.5	121.5	105	65 h6	410	409	153	105	65 h6
25004	483					483					483				

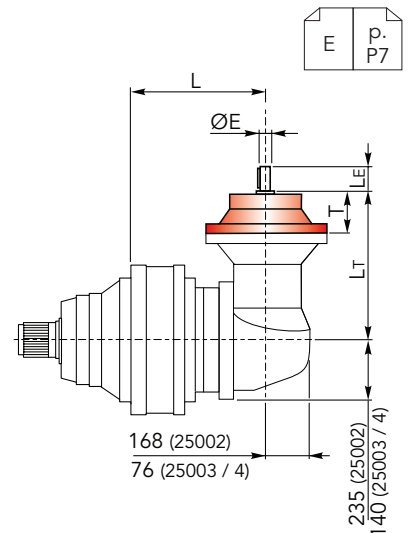



## DIMENSIONI CMC

## CMC DIMENSIONS

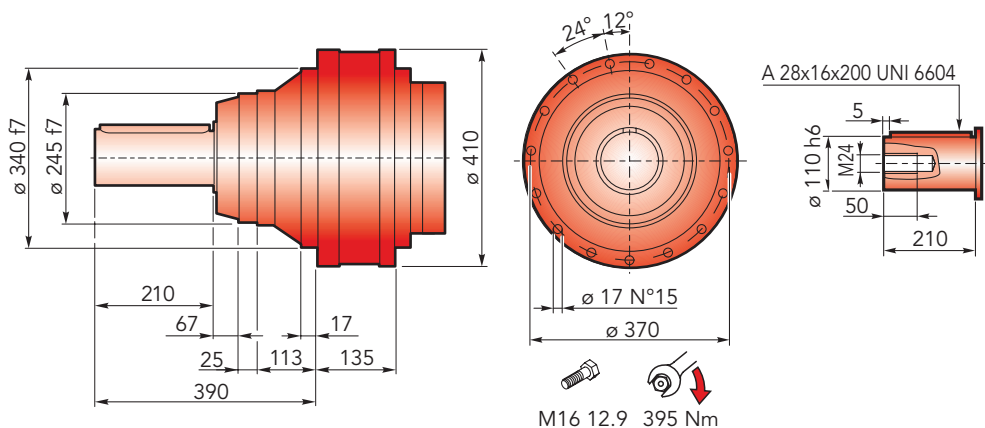

## CHPL 25000 CMC - Flange motori IEC

## CHPL 25000 CMC- IEC Motor flanges

CHPL	IEC 63			IEC 71			IEC 80			IEC 90			IEC 100			IEC 112		
	Lp	P	ØD	Lp	P	ØD	Lp	P	ØD	Lp	P	ØD	Lp	P	ØD	Lp	P	ØD
25001	-	-	-	-	-	-	-	-	-	-	-	-	-	-	-	-	-	-
25002	-	-	-	-	-	-	-	-	-	-	-	-	-	-	-	-	-	-
25003	419.5	36	140	419.5	36	160	439.5	56	200	439.5	56	200	449.5	66	250	449.5	66	250
25004	467.5	36	140	467.5	36	160	487.5	56	200	487.5	56	200	497.5	66	250	497.5	66	250

CHPL	IEC 132			IEC 160			IEC 180			IEC 200			IEC 225			IEC 250		
	Lp	P	ØD	Lp	P	ØD	Lp	P	ØD	Lp	P	ØD	Lp	P	ØD	Lp	P	ØD
25001	-	-	-	380	150	-	380	150	-	380	150	400	369	139	450	369	139	550
25002	-	-	-	442	118	350	442	118	350	472	148	400	-	-	-	-	-	-
25003	483.5	100	300	522.5	139		522.5	139	-	-	-	-	-	-	-	-	-	-
25004	531.5	100	300	570.5	139	-	-	-	-	-	-	-	-	-	-	-	-	

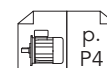
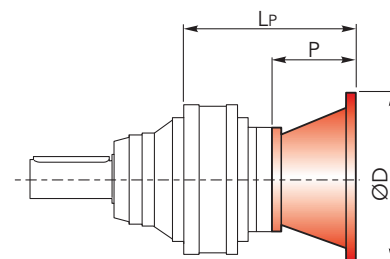

## CHPL 25000 CMC - Alberi maschi entrata

## CHPL 25000 CMC - Male input shafts

CHPL	CM42				CM65				CP65			
	Lt	T	Le	ØE	Lt	T	Le	ØE	Lt	T	Le	ØE
25001	-	-	-	-	-	-	-	-	-	-	-	-
25002	-	-	-	-	445.5	121.5	105	65 h6	477	153	105	65 h6
25003	476.5	93	82	42 h6	518.5	-	-	-	550	-	-	-
25004	524.5	-	-	-	-	-	-	-	-	-	-	-

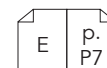
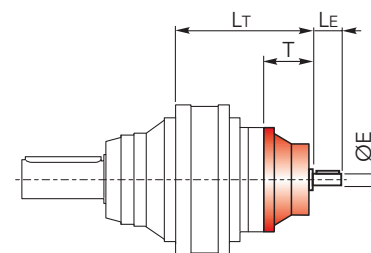





## DIMENSIONI CMC

## CMC DIMENSIONS

CHPL/CHPLB 25000

CHPL 25000 CMC - Riduttore a vite senza fine CHM in entrata CHPL 25000 CMC - CHM input worm gearboxes

CHPL	CHM 50					CHM 63					CHM 75				
	Lv	I	H	M	N	Lv	I	H	M	N	Lv	I	H	M	N
25001	-					-					-				
25002	-					-					-				
25003	509	50	110	60	80	518.5	63	135	72	95	497.5	75	161	86	112.5
25004	557					566.5					545.5				

CHPL	CHM 90					CHM 110					CHM 130					
	Lv	I	H	M	N	Lv	I	H	M	N	Lv	I	H	M	N	
25001	-					-					-					
25002	-					462	110	237.5	127.5	160	469	130	277.5	147.5	180	
25003	507.5	90	193	103	129.5	535				542						
25004	555.5															

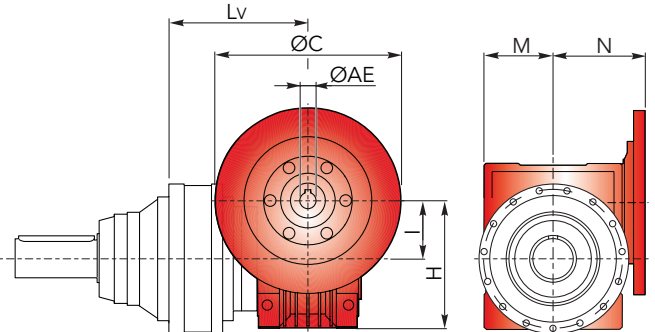

CHPLB 25000 CMC - Flange motori IEC

CHPLB 25000 CMC - IEC Motor flanges

CHPLB	IEC 63				IEC 71				IEC 80				IEC 90				IEC 100			
	L	Lp	P	ØD	L	Lp	P	ØD	L	Lp	P	ØD	L	Lp	P	ØD	L	Lp	P	ØD
25002	-				-				-				-				-			
25003	410	276	36	140	410	276	36	160	410	296	56	200	410	296	56	200	410	306	66	250
25004	483				483				483				483				483			

CHPLB	IEC 112				IEC 132				IEC 160				IEC 180				IEC 200			
	L	Lp	P	ØD	L	Lp	P	ØD	L	Lp	P	ØD	L	Lp	P	ØD	L	Lp	P	ØD
25002	-				-				308	433	118		308	433	118		308	463	148	400
25003	410	306	66	250	410	340	100	300	410	379	139	350	410	379	139	350				
25004	483				483				483											

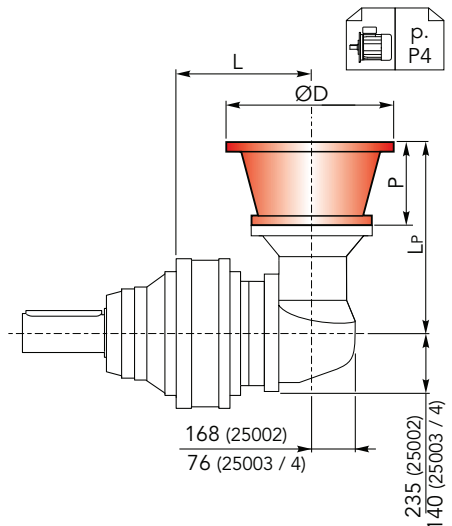

CHPLB 25000 CMC - Alberi maschi entrata

CHPL 25000 CMC - Male input shafts

CHPLB	CM42					CM65					CP65				
	L	Lt	T	Le	ØE	L	Lt	T	Le	ØE	L	Lt	T	Le	ØE
25002	-					308	436.5				308	468			
25003	410	333	93	82	42 h6	410	377.5	121.5	105	65 h6	410	409	153	105	65 h6
25004	483					483					483				

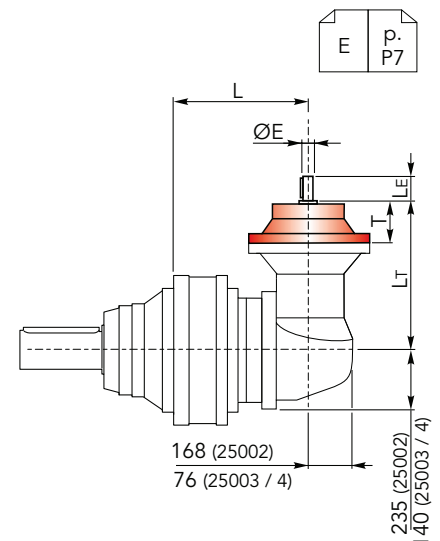



## DIMENSIONI CF

## CF DIMENSIONS

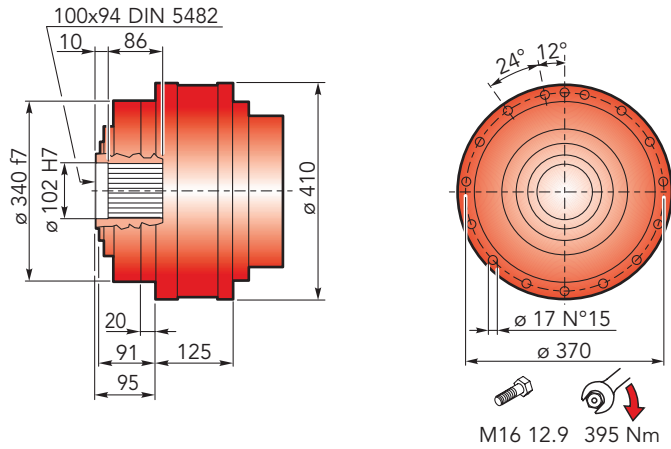

Accessori  
Accessories

CHKB

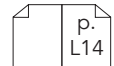

## CHPL 25000 CF - Flange motori IEC

## CHPL 25000 CF- IEC Motor flanges

CHPL	IEC 63			IEC 71			IEC 80			IEC 90			IEC 100			IEC 112		
	Lp	P	ØD	Lp	P	ØD	Lp	P	ØD	Lp	P	ØD	Lp	P	ØD	Lp	P	ØD
25001	-	-	-	-	-	-	-	-	-	-	-	-	-	-	-	-	-	-
25002	-	-	-	-	-	-	-	-	-	-	-	-	-	-	-	-	-	-
25003	409.5	36	140	409.5	36	160	429.5	56	200	429.5	56	200	439.5	66	250	439.5	66	250
25004	457.5	36	140	457.5	36	160	477.5	56	200	477.5	56	200	487.5	66	250	487.5	66	250

CHPL	IEC 132			IEC 160			IEC 180			IEC 200			IEC 225			IEC 250		
	Lp	P	ØD	Lp	P	ØD	Lp	P	ØD	Lp	P	ØD	Lp	P	ØD	Lp	P	ØD
25001	-	-	-	370	150	-	370	150	-	370	150	400	359	139	450	359	139	550
25002	-	-	-	432	118	350	432	118	350	462	148	400	-	-	-	-	-	-
25003	473.5	100	300	512.5	139	350	512.5	139	350	-	-	-	-	-	-	-	-	-
25004	521.5	100	300	560.5	139	350	-	-	-	-	-	-	-	-	-	-	-	-

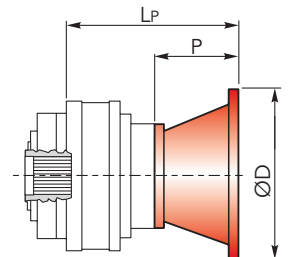

## CHPL 25000 CF - Alberi maschi entrata

## CHPL 25000 CF - Male input shafts

CHPL	CM42				CM65				CP65			
	Lt	T	Le	ØE	Lt	T	Le	ØE	Lt	T	Le	ØE
25001	-	-	-	-	-	-	-	-	-	-	-	-
25002	-	-	-	-	435.5	121.5	105	65 h6	467	153	105	65 h6
25003	466.5	93	82	42 h6	508.5	-	-	-	540	-	-	-
25004	514.5	-	-	-	-	-	-	-	-	-	-	-

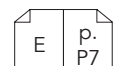
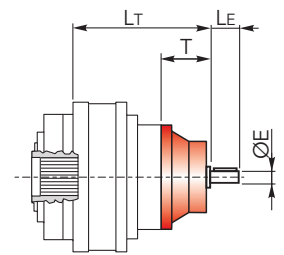



## DIMENSIONI CF

## CF DIMENSIONS

CHPL/CHPLB 25000

CHPL 25000 CF - Riduttore a vite senza fine CHM in entrata

CHPL 25000 CF - CHM input worm gearboxes

CHPL	CHM 50					CHM 63					CHM 75				
	Lv	I	H	M	N	Lv	I	H	M	N	Lv	I	H	M	N
25001	-					-					-				
25002	-					-					-				
25003	499	50	110	60	80	508.5	63	135	72	95	487.5	75	161	86	112.5
25004	547					556.5					535.5				

CHPL	CHM 90					CHM 110					CHM 130					
	Lv	I	H	M	N	Lv	I	H	M	N	Lv	I	H	M	N	
25001	-					-					-					
25002	-					452					459					
25003	497.5	90	193	103	129.5	525	110	237.5	127.5	160	532	130	277.5	147.5	180	
25004	545.5															

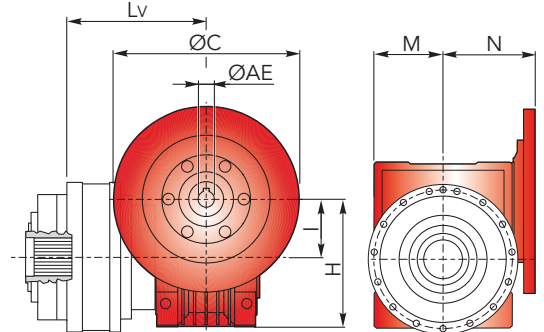

CHPLB 25000 CF - Flange motori IEC

CHPLB 25000 CF - IEC Motor flanges

CHPLB	IEC 63				IEC 71				IEC 80				IEC 90				IEC 100			
	L	Lp	P	ØD	L	Lp	P	ØD	L	Lp	P	ØD	L	Lp	P	ØD	L	Lp	P	ØD
25002	-				-				-				-				-			
25003	400	276	36	140	400	276	36	160	400	296	56	200	400	296	56	200	400	306	66	250
25004	473				473				473				473				473			

CHPLB	IEC 112				IEC 132				IEC 160				IEC 180				IEC 200			
	L	Lp	P	ØD	L	Lp	P	ØD	L	Lp	P	ØD	L	Lp	P	ØD	L	Lp	P	ØD
25002	-				-				298	433	118		298	433	118		298	463	148	400
25003	400				400				400	379	139	350	400	379	139	350				
25004	473	306	66	250	473	340	100	300	473											

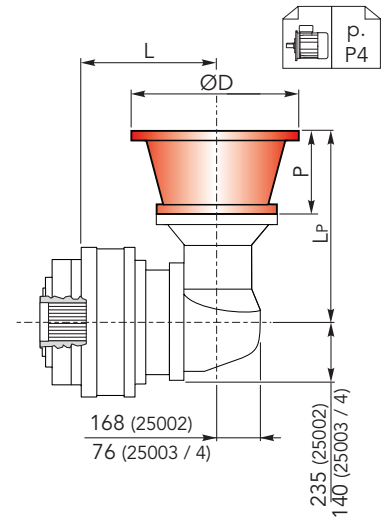

CHPLB 25000 CF - Alberi maschi entrata

CHPL 25000 CF - Male input shafts

CHPLB	CM42					CM65					CP65				
	L	Lt	T	Le	ØE	L	Lt	T	Le	ØE	L	Lt	T	Le	ØE
25002	-					298	436.5				298	468			
25003	400	333	93	82	42 h6	400	377.5	121.5	105	65 h6	400	409	153	105	65 h6
25004	473					473					473				

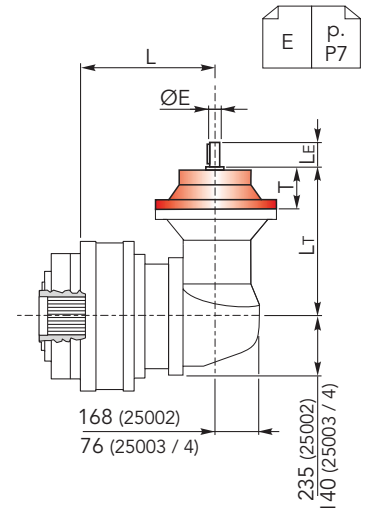



## DIMENSIONI CFS

## CFS DIMENSIONS

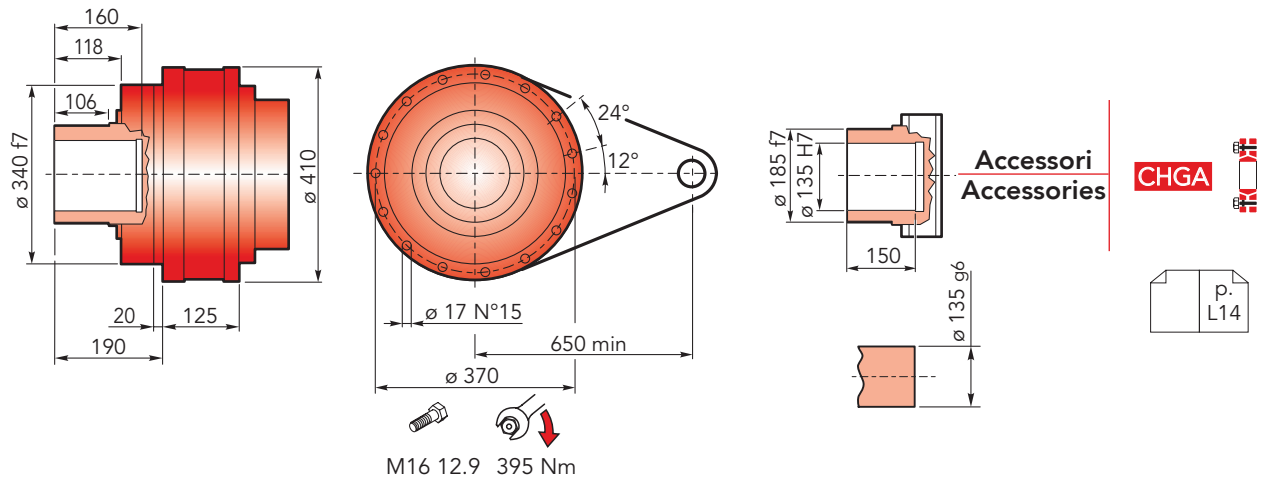

## CHPL 25000 CFS - Flange motori IEC

## CHPL 25000 CFS- IEC Motor flanges

CHPL	IEC 63			IEC 71			IEC 80			IEC 90			IEC 100			IEC 112		
	Lp	P	ØD	Lp	P	ØD	Lp	P	ØD	Lp	P	ØD	Lp	P	ØD	Lp	P	ØD
25001	-	-	-	-	-	-	-	-	-	-	-	-	-	-	-	-	-	-
25002	-	-	-	-	-	-	-	-	-	-	-	-	-	-	-	-	-	-
25003	409.5	36	140	409.5	36	160	429.5	56	200	429.5	56	200	439.5	66	250	439.5	66	250
25004	457.5	36	140	457.5	36	160	477.5	56	200	477.5	56	200	487.5	66	250	487.5	66	250

CHPL	IEC 132			IEC 160			IEC 180			IEC 200			IEC 225			IEC 250		
	Lp	P	ØD	Lp	P	ØD	Lp	P	ØD	Lp	P	ØD	Lp	P	ØD	Lp	P	ØD
25001	-	-	-	370	150	-	370	150	-	370	150	400	359	139	450	359	139	550
25002	-	-	-	432	118	350	432	118	350	462	148	400	-	-	-	-	-	-
25003	473.5	100	300	512.5	139	350	512.5	139	350	-	-	-	-	-	-	-	-	-
25004	521.5	100	300	560.5	139	350	-	-	-	-	-	-	-	-	-	-	-	-

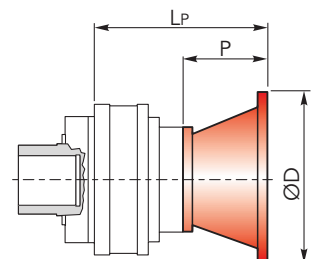

## CHPL 25000 CFS - Alberi maschi entrata

## CHPL 25000 CFS - Male input shafts

CHPL	CM42				CM65				CP65			
	Lt	T	Le	ØE	Lt	T	Le	ØE	Lt	T	Le	ØE
25001	-	-	-	-	-	-	-	-	-	-	-	-
25002	-	-	-	-	435.5	121.5	105	65 h6	467	153	105	65 h6
25003	466.5	93	82	42 h6	508.5	-	-	-	540	-	-	-
25004	514.5	-	-	-	-	-	-	-	-	-	-	-

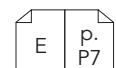
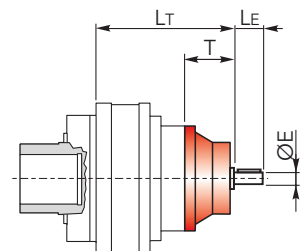



## DIMENSIONI CFS

## CFS DIMENSIONS

CHPL 25000 CFS - Riduttore a vite senza fine CHM in entrata CHPL 25000 CFS - CHM input worm gearboxes

CHPL	CHM 50					CHM 63					CHM 75				
	Lv	I	H	M	N	Lv	I	H	M	N	Lv	I	H	M	N
25001	-					-					-				
25002	-					-					-				
25003	499	50	110	60	80	508.5	63	135	72	95	487.5	75	161	86	112.5
25004	547					556.5					535.5				

CHPL	CHM 90					CHM 110					CHM 130					
	Lv	I	H	M	N	Lv	I	H	M	N	Lv	I	H	M	N	
25001	-					-					-					
25002	-					452	110	237.5	127.5	160	459	130	277.5	147.5	180	
25003	497.5	90	193	103	129.5	525					532					
25004	545.5															

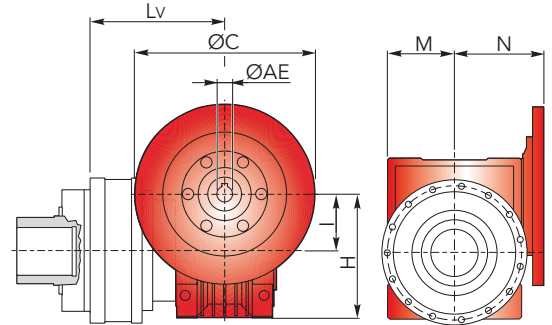

## CHPLB 25000 CFS - Flange motori IEC

## CHPLB 25000 CFS - IEC Motor flanges

CHPLB	IEC 63				IEC 71				IEC 80				IEC 90				IEC 100			
	L	Lp	P	ØD	L	Lp	P	ØD	L	Lp	P	ØD	L	Lp	P	ØD	L	Lp	P	ØD
25002	-				-				-				-				-			
25003	400	276	36	140	400	276	36	160	400	296	56	200	400	296	56	200	400	306	66	250
25004	473				473				473				473				473			

CHPLB	IEC 112				IEC 132				IEC 160				IEC 180				IEC 200			
	L	Lp	P	ØD	L	Lp	P	ØD	L	Lp	P	ØD	L	Lp	P	ØD	L	Lp	P	ØD
25002	-				-				298	433	118		298	433	118		298	463	148	400
25003	400	306	66	250	400	340	100	300	400	379	139	350	400	379	139	350				
25004	473				473				473											

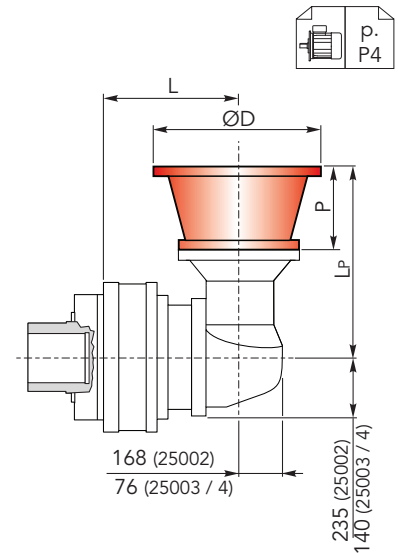

## CHPLB 25000 CFS - Alberi maschi entrata

## CHPL 25000 CFS - Male input shafts

CHPLB	CM42					CM65					CP65				
	L	Lt	T	Le	ØE	L	Lt	T	Le	ØE	L	Lt	T	Le	ØE
25002	-					298	436.5				298	468			
25003	400	333	93	82	42 h6	400	377.5	121.5	105	65 h6	400	409	153	105	65 h6
25004	473					473					473				

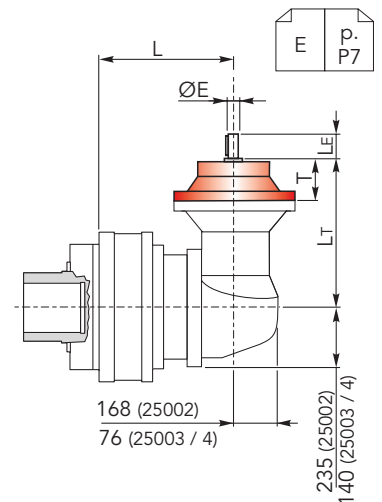



## DIMENSIONI CCPC

## CCPC DIMENSIONS

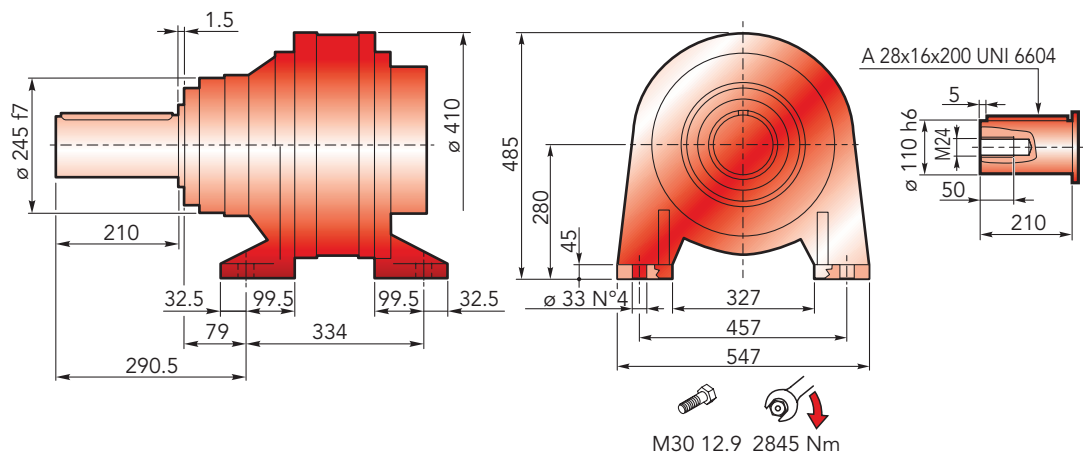

## CHPL 25000 CCPC - Flange motori IEC

## CHPL 25000 CCPC- IEC Motor flanges

CHPL	IEC 63			IEC 71			IEC 80			IEC 90			IEC 100			IEC 112		
	Lp	P	ØD	Lp	P	ØD	Lp	P	ØD	Lp	P	ØD	Lp	P	ØD	Lp	P	ØD
25001	-	-	-	-	-	-	-	-	-	-	-	-	-	-	-	-	-	-
25002	-	-	-	-	-	-	-	-	-	-	-	-	-	-	-	-	-	-
25003	599.5	36	140	599.5	36	160	619.5	56	200	619.5	56	200	629.5	66	250	629.5	66	250
25004	647.5	36	140	647.5	36	160	667.5	56	200	667.5	56	200	677.5	66	250	677.5	66	250

CHPL	IEC 132			IEC 160			IEC 180			IEC 200			IEC 225			IEC 250		
	Lp	P	ØD	Lp	P	ØD	Lp	P	ØD	Lp	P	ØD	Lp	P	ØD	Lp	P	ØD
25001	-	-	-	560	150	-	560	150	-	560	150	400	549	139	450	549	139	550
25002	-	-	-	622	118	350	622	118	350	622	148	400	-	-	-	-	-	-
25003	663.5	100	300	702.5	139		702.5	139	-	-	-	-	-	-	-	-	-	-
25004	711.5	100	300	750.5	139	-	-	-	-	-	-	-	-	-	-	-	-	

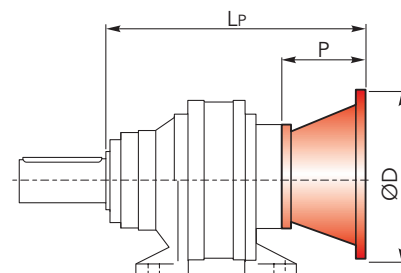

## CHPL 25000 CCPC - Alberi maschi entrata

## CHPL 25000 CCPC - Male input shafts

CHPL	CM42				CM65				CP65			
	Lt	T	Le	ØE	Lt	T	Le	ØE	Lt	T	Le	ØE
25001	-	-	-	-	-	-	-	-	-	-	-	-
25002	-	-	-	-	625.5	121.5	105	65 h6	657	153	105	65 h6
25003	656.5	93	82	42 h6	698.5	-	-	-	730	-	-	-
25004	704.5	-	-	-	-	-	-	-	-	-	-	-

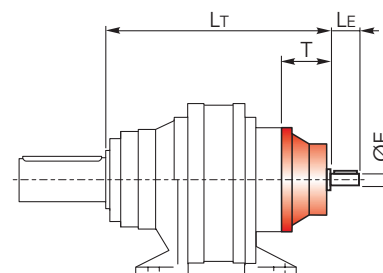



## DIMENSIONI CCPC

## CCPC DIMENSIONS

CHPL/CHPLB 25000

CHPL 25000 CCPC - Riduttore a vite senza fine CHM in entrata CHPL 25000 CCPC - CHM input worm gearboxes

CHPL	CHM 50					CHM 63					CHM 75				
	Lv	I	H	M	N	Lv	I	H	M	N	Lv	I	H	M	N
25001	-					-					-				
25002	-					-					-				
25003	689	50	110	60	80	698.5	63	135	72	95	677.5	75	161	86	112.5
25004	737					746.5					725.5				

CHPL	CHM 90					CHM 110					CHM 130					
	Lv	I	H	M	N	Lv	I	H	M	N	Lv	I	H	M	N	
25001	-					-					-					
25002	-					642	110	237.5	127.5	160	649	130	277.5	147.5	180	
25003	687.5	90	193	103	129.5	715					722					
25004	735.5															

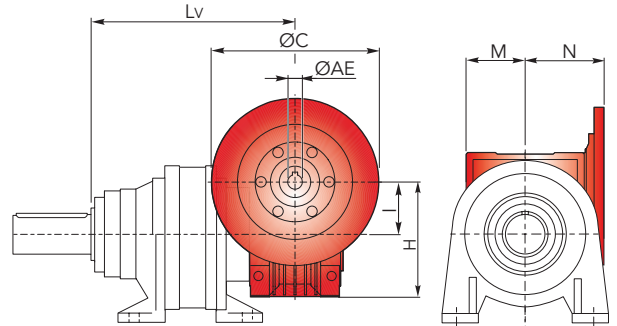

CHPLB 25000 CCPC - Flange motori IEC

CHPLB 25000 CCPC - IEC Motor flanges

CHPLB	IEC 63				IEC 71				IEC 80				IEC 90				IEC 100			
	L	Lp	P	ØD	L	Lp	P	ØD	L	Lp	P	ØD	L	Lp	P	ØD	L	Lp	P	ØD
25002	-				-				-				-				-			
25003	590	276	36	140	590	276	36	160	590	296	56	200	590	296	56	200	590	306	66	250
25004	663				663				663				663				663			

CHPLB	IEC 112				IEC 132				IEC 160				IEC 180				IEC 200			
	L	Lp	P	ØD	L	Lp	P	ØD	L	Lp	P	ØD	L	Lp	P	ØD	L	Lp	P	ØD
25002	-				-				590	433	118		488	433	118		488	463	148	400
25003	590	306	66	250	590	340	100	300	663	379	139	350	590	379	139					
25004	663				663				663											

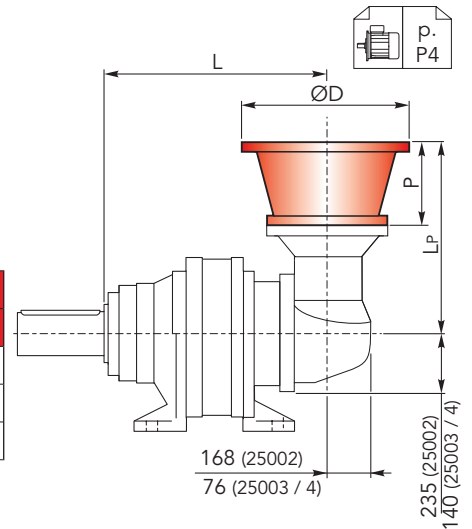

CHPLB 25000 CCPC - Alberi maschi entrata

CHPL 25000 CCPC - Male input shafts

CHPLB	CM42					CM65					CP65				
	L	Lt	T	Le	ØE	L	Lt	T	Le	ØE	L	Lt	T	Le	ØE
25002	-					590	436.5				590	468			
25003	590	333	93	82	42 h6	663	377.5	121.5	105	65 h6	663	409	153	105	65 h6
25004	663					650					650				

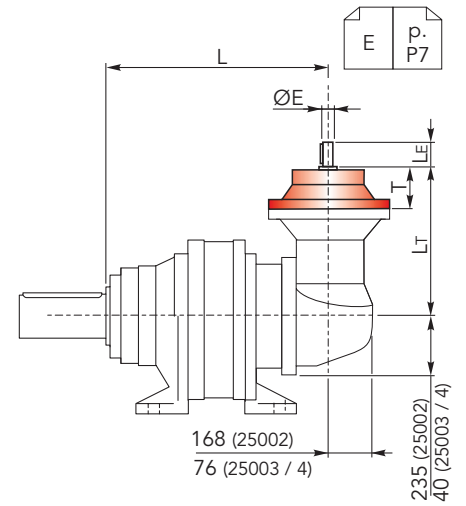



## ACCESSORI

## ACCESSORIES

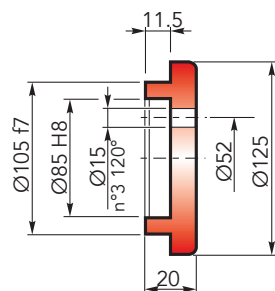
**CHFF**  **Fondello di arresto / Stop bottom plate**

Codice / Code:  
1075.042.000

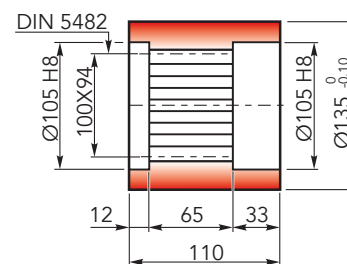
**CHBS**  **Boccola scanalata / Splined bushing**

Codice / Code:  
8171.112.041

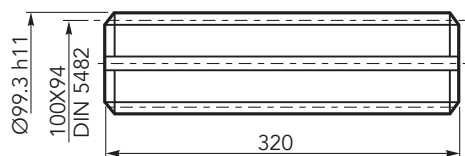
**CHKB**  **Barra scanalata / Splined rod**

Codice / Code:  
3071.407.042

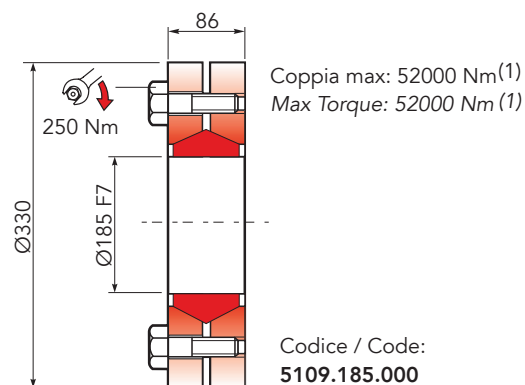
**CHGA**  **Giunto di attrito / Shrink disc**

Codice / Code:  
5109.185.000

(1): Coppia max indicata è valida solo con calettatori forniti da Chiaravalli S.p.A.

(1): The maximum torque indicated is valid only with shrink discs supplied by Chiaravalli S.p.A.

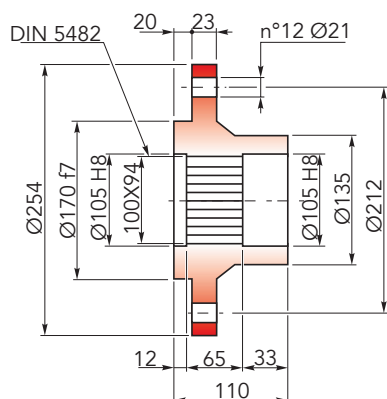
**CHFL**  **Flangia / Flange**

Codice / Code:  
8171.104.098





## CARICHI RADIALI (Fr)

## RADIAL LOADS (Fr)

Nel diagramma seguente, sono indicati i carichi radiali  $F_r$  (N) applicabili sull'albero uscita in funzione della distanza di applicazione  $L$  rispetto alla battuta dell'albero.

The hereunder table shows the allowable radial loads  $F_r$  (N) on the output shaft with reference to the distance  $L$ .

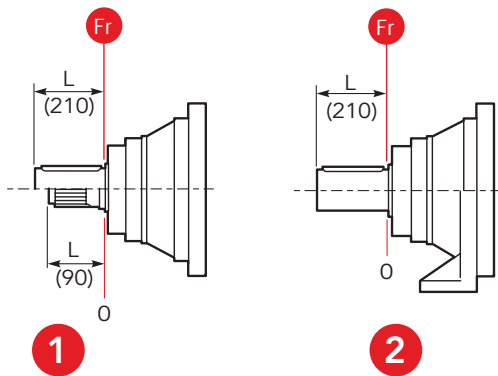
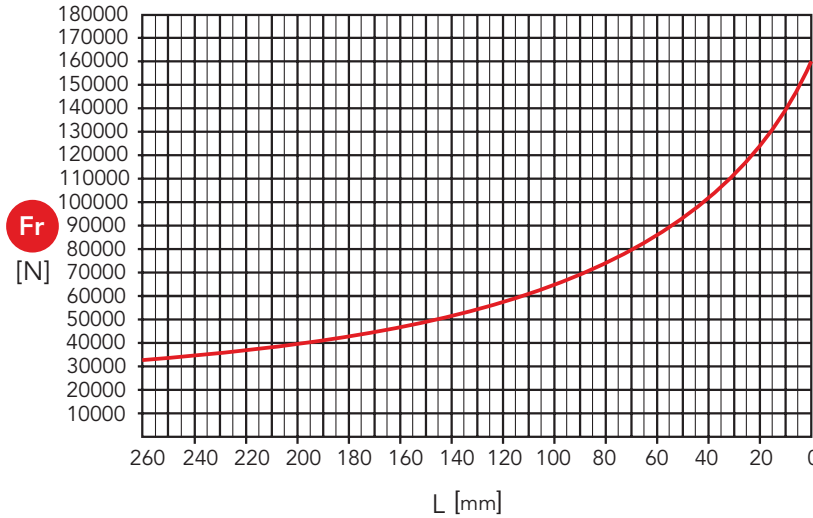

- 1 Uscita / Output: CMS, CMC
- 2 Uscita / Output: CCPC

## CARICHI ASSIALI (Fa)

## AXIAL LOADS (Fa)

Nella tabella seguente sono indicati i carichi assiali  $F_a$  (N) applicabili sull'albero di uscita in funzione della direzione di applicazione del carico e della versione.

The hereunder table shows the allowable axial loads  $F_a$  (N) on the output shaft with reference to the load direction and the output type.

	1	2	
$F_a$ [N]	75000	75000	←
	95000	95000	→

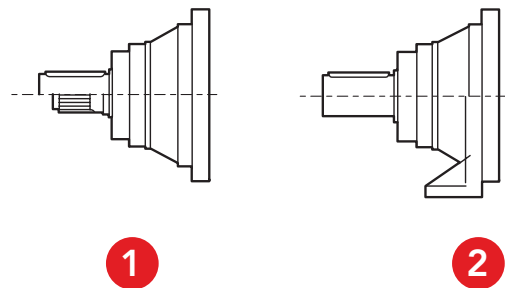

- 1 Uscita / Output: CMS, CMC
- 2 Uscita / Output: CCPC





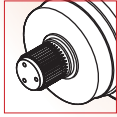
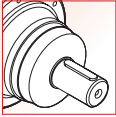
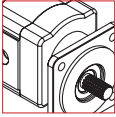
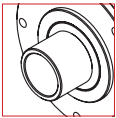
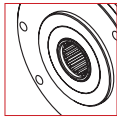
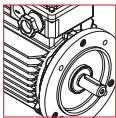
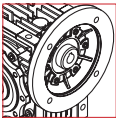
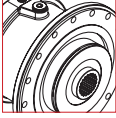

# CHPL/CHPLB 30000

	<b>i</b>	<b>T<sub>2n</sub></b> (daNm)	<b>OUT</b>		<b>IN</b>	
<b>30002</b>	14.2 ÷ 35.1	1735.7 ÷ 2244.9	 Ø110	 100X94 DIN 5482	 Ø42 Ø65	 Hydraulic Motor
<b>30003</b>	64.8 ÷ 134.4	2244.9	 Ø135	 100X94 DIN 5482	 Electric Motor	 Worm gearboxes
<b>30004</b>	251.4 ÷ 1425.1	1735.7 ÷ 2244.9			 Brake	

## CHPL

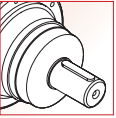
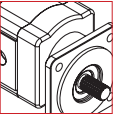
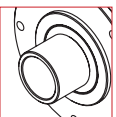
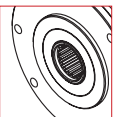
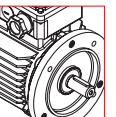
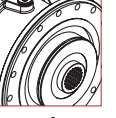

	<b>i</b>	<b>T<sub>2n</sub></b> (daNm)	<b>OUT</b>		<b>IN</b>	
<b>30003</b>	52.7 ÷ 163.8	1735.7 ÷ 2244.9	 Ø110	 100X94 DIN 5482	 Ø42 Ø65	 Hydraulic Motor
<b>30004</b>	306.0 ÷ 1385.5	1735.7 ÷ 2244.9	 Ø135	 100X94 DIN 5482	 Electric Motor	 Brake

## CHPLB

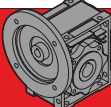

## DATI TECNICI

## TECHNICAL DATA



 CHPL	i	T <sub>2n</sub> (n <sub>1</sub> =1400 rpm) [daNm]	P <sub>1n</sub> (n <sub>1</sub> =1400 rpm) [kW]	P <sub>t</sub> [kW]	IEC (B5)	 CHM	 CM / CP
<b>30002</b>	14.2	2244.9	232	34	160   180 200	CHM 110 CHM 130 CHM 150	CM65 CP65
	17.1	2244.9	192				
	22.4	2244.9	147				
	29.1	1735.7	87				
	35.1	1735.7	72				
<b>30003</b>	64.8	2244.9	51	23	63   71 80   90 100   112 132   160 180	CHM 50 CHM 63 CHM 75 CHM 90 CHM 110 CHM 130 CHM 150	CM42 CM65 CP65
	73.5	2244.9	45				
	88.6	2244.9	37				
	102.9	2244.9	32				
	124.3	2244.9	26				
	134.4	2244.9	24				
	<b>30004</b>	251.4	2244.9				
300.9		2244.9	11				
314.9		2244.9	10				
328.5		2244.9	10				
362.7		2244.9	9.1				
379.6		2244.9	8.7				
396		2244.9	8.3				
427.1		2244.9	7.7				
477.3		2244.9	6.9				
517.4		2244.9	6.4				
576		2244.9	5.7				
623.7		2244.9	5.3				
694.3		2244.9	4.7				
752.6		2244.9	4.4				
838.9		2244.9	3.9				
1015.5	1735.7	2.5					
1425.1	1735.7	1.8					

n<sub>1max</sub> = 2800 rpmSolo per / Only for CHPL 30002: n<sub>1max</sub> = 2000 rpm

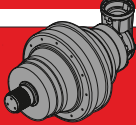

## DATI TECNICI

## TECHNICAL DATA

 CHPLB	i	T <sub>2n</sub> (n <sub>1</sub> =1400 rpm)	P <sub>1n</sub> (n <sub>1</sub> =1400 rpm)	P <sub>t</sub>	IEC	 CM / CP
		[daNm]	[kW]	[kW]	(B5)	
<b>30003</b>	52.7	2244.9	62	23	160   180	CM65 CP65
	66.4	2244.9	50			
	80	2244.9	41			
	104.5	2244.9	31			
	135.9	1735.7	19			
	163.8	1735.7	16			
<b>30004</b>	306	2244.9	11	17	63   71 80   90 100   112 132   160	CM42 CM65 CP65
	352.6	2244.9	9.3			
	385	2244.9	8.5			
	460.7	2244.9	7.1			
	519.8	1735.7	4.9			
	598.9	1735.7	4.2			
	676.7	2244.9	4.9			
	729.3	1735.7	3.5			
	819.1	1735.7	3.1			
	951.2	1735.7	2.7			
	1385.5	1735.7	1.8			

n<sub>1max</sub> = 2800 rpm

CHPL/CHPLB 30000



## DIMENSIONI CMS

## CMS DIMENSIONS

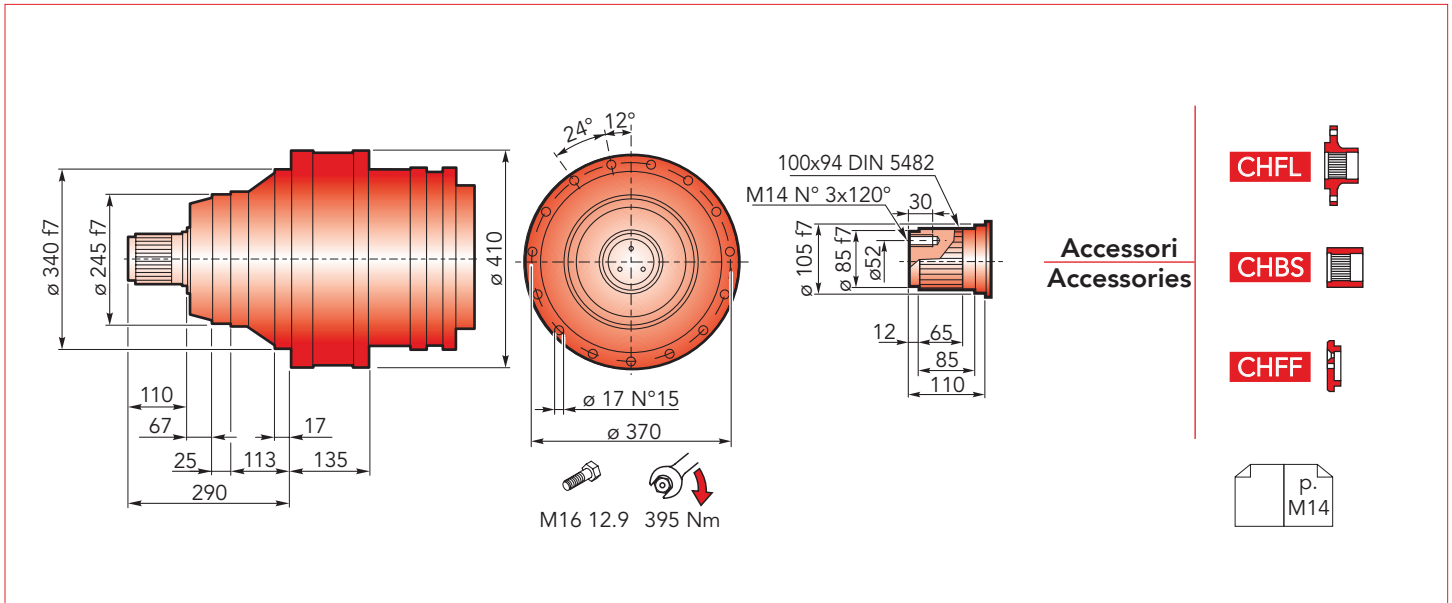

## CHPL 30000 CMS - Flange motori IEC

## CHPL 30000 CMS- IEC Motor flanges

CHPL	IEC 63			IEC 71			IEC 80			IEC 90			IEC 100		
	LP	P	ØD	LP	P	ØD	LP	P	ØD	LP	P	ØD	LP	P	ØD
30002	-	-	-	-	-	-	-	-	-	-	-	-	-	-	-
30003	424.5	36	140	424.5	36	160	444.5	56	200	444.5	56	200	454.5	66	250
30004	485.5	-	-	485.5	-	-	505.5	-	-	505.5	-	-	515.5	-	-

CHPL	IEC 112			IEC 132			IEC 160			IEC 180			IEC 200		
	LP	P	ØD	LP	P	ØD	LP	P	ØD	LP	P	ØD	LP	P	ØD
30002	-	-	-	-	-	-	435	118	350	435	118	350	465	148	400
30003	454.5	66	250	488.5	100	300	527.5	139	350	527.5	139	350	-	-	-
30004	515.5	-	-	549.5	-	-	588.5	-	-	-	-	-	-	-	-

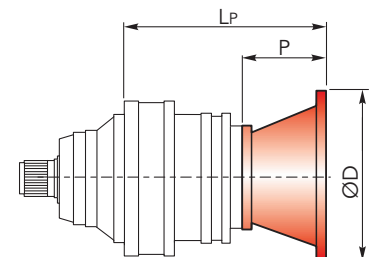

## CHPL 30000 CMS - Alberi maschi entrata

## CHPL 30000 CMS - Male input shafts

CHPL	CM42				CM65				CP65			
	LT	T	LE	ØE	LT	T	LE	ØE	LT	T	LE	ØE
30002	-	-	-	-	438.5	121.5	105	65 h6	470	153	105	65 h6
30003	481.5	93	82	42 h6	523.5	-	-	-	555	-	-	-
30004	542.5	-	-	-	-	-	-	-	-	-	-	-

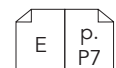
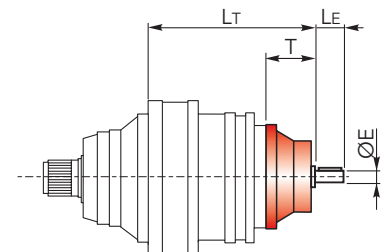



## DIMENSIONI CMS

## CMS DIMENSIONS

CHPL/CHPLB 30000

CHPL 30000 CMS - Riduttore a vite senza fine CHM in entrata

CHPL 30000 CMS - CHM input worm gearboxes

CHPL	CHM 50					CHM 63					CHM 75				
	Lv	I	H	M	N	Lv	I	H	M	N	Lv	I	H	M	N
30002	-					-					-				
30003	514	50	110	60	80	523.5	63	135	72	95	502.5	75	161	86	112.5
30004	575					584.5					563.5				

CHPL	CHM 90					CHM 110					CHM 130				
	Lv	I	H	M	N	Lv	I	H	M	N	Lv	I	H	M	N
30002	-					455	110	237.5	127.5	160	462	130	277.5	147.5	180
30003	512.5	90	193	103	129.5	540					547				
30004	573.5					-					-				

CHPL	CHM 150				
	Lv	I	H	M	N
30002	477	150	320	170	210
30003	562				
30004	-				

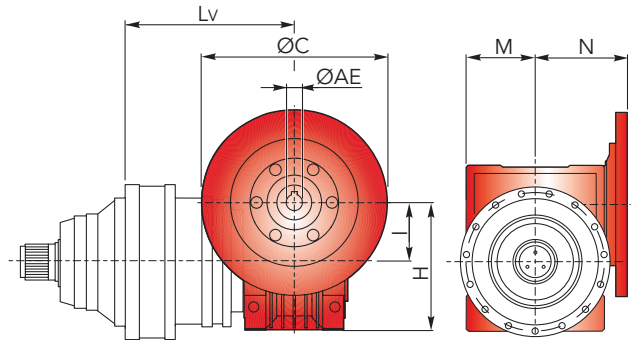

$\varnothing C$  p.  
 $\varnothing AE$  P6

CHPLB 30000 CMS - Flange motori IEC

CHPLB 30000 CMS - IEC Motor flanges

CHPLB	IEC 63				IEC 71				IEC 80				IEC 90			
	L	LP	P	ØD	L	LP	P	ØD	L	LP	P	ØD	L	LP	P	ØD
30003	-				-				-				-			
30004	490	276	36	140	490	276	36	160	490	296	56	200	490	296	56	200

CHPLB	IEC 100				IEC 112				IEC 132				IEC 160				IEC 180			
	L	LP	P	ØD	L	LP	P	ØD	L	LP	P	ØD	L	LP	P	ØD	L	LP	P	ØD
30003	-				-				-				452	433	118	350	452	433	118	350
30004	490	306	66	250	490	306	66	250	490	340	100	300	490	379	139					

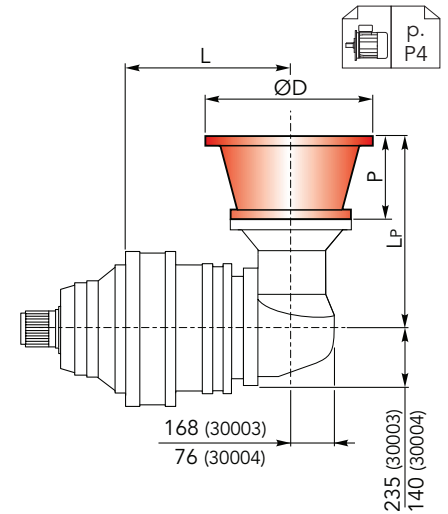

CHPLB 30000 CMS - Alberi maschi entrata

CHPL 30000 CMS - Male input shafts

CHPLB	CM42					CM65					CP65				
	L	L <sub>T</sub>	T	L <sub>E</sub>	ØE	L	L <sub>T</sub>	T	L <sub>E</sub>	ØE	L	L <sub>T</sub>	T	L <sub>E</sub>	ØE
30003	-					452	436.5	121.5	105	65 h6	452	468	153	105	65 h6
30004	490	333	93	82	42 h6	490	377.5				490	409			

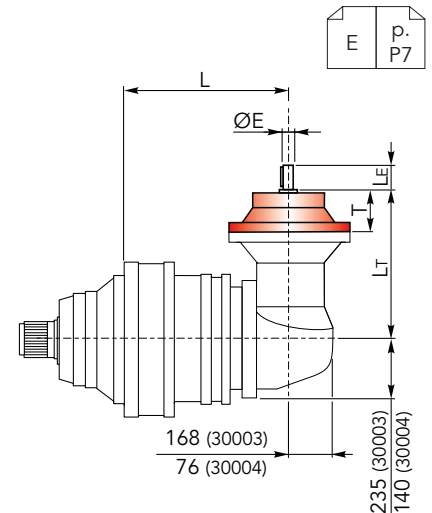



## DIMENSIONI CMC

## CMC DIMENSIONS

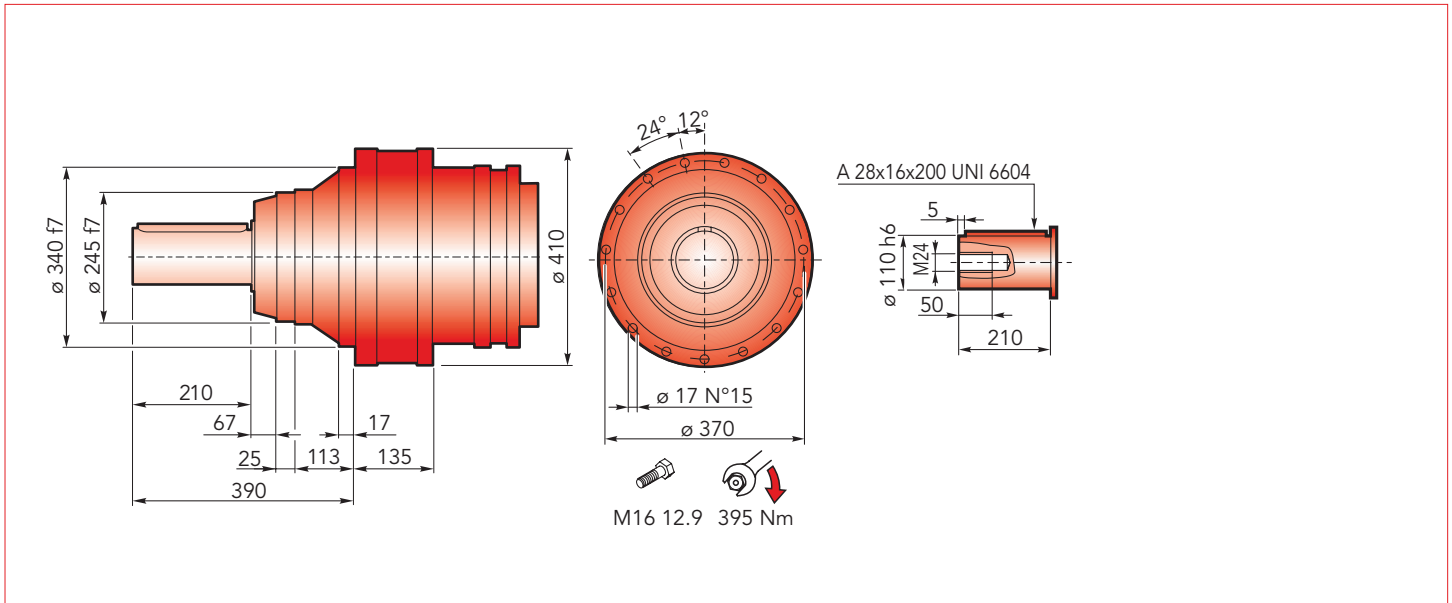

## CHPL 30000 CMC - Flange motori IEC

## CHPL 30000 CMC- IEC Motor flanges

CHPL	IEC 63			IEC 71			IEC 80			IEC 90			IEC 100		
	LP	P	ØD	LP	P	ØD	LP	P	ØD	LP	P	ØD	LP	P	ØD
30002	-	-	-	-	-	-	-	-	-	-	-	-	-	-	-
30003	424.5	36	140	424.5	36	160	444.5	56	200	444.5	56	200	454.5	66	250
30004	485.5	-	-	485.5	-	-	505.5	-	-	505.5	-	-	515.5	-	-

CHPL	IEC 112			IEC 132			IEC 160			IEC 180			IEC 200		
	LP	P	ØD	LP	P	ØD	LP	P	ØD	LP	P	ØD	LP	P	ØD
30002	-	-	-	-	-	-	435	118	350	435	118	350	465	148	400
30003	454.5	66	250	488.5	100	300	527.5	139	350	527.5	139	350	-	-	-
30004	515.5	-	-	549.5	-	-	588.5	-	-	-	-	-	-	-	-

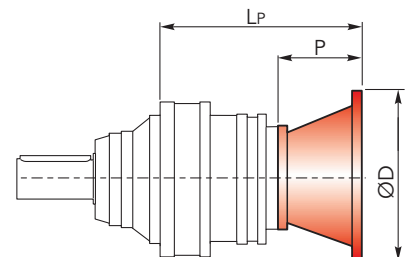

## CHPL 30000 CMC - Alberi maschi entrata

## CHPL 30000 CMC - Male input shafts

CHPL	CM42				CM65				CP65			
	LT	T	LE	ØE	LT	T	LE	ØE	LT	T	LE	ØE
30002	-	-	-	-	438.5	121.5	105	65 h6	470	153	105	65 h6
30003	481.5	93	82	42 h6	523.5	-	-	-	555	-	-	-
30004	542.5	-	-	-	-	-	-	-	-	-	-	-

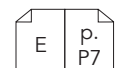
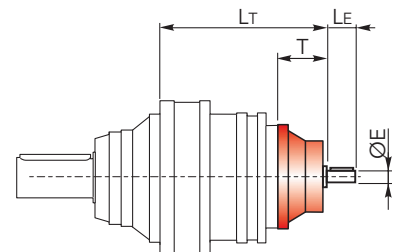





## DIMENSIONI CMC

## CMC DIMENSIONS

CHPL/CHPLB 30000

CHPL 30000 CMC - Riduttore a vite senza fine CHM in entrata CHPL 30000 CMC - CHM input worm gearboxes

CHPL	CHM 50					CHM 63					CHM 75				
	Lv	I	H	M	N	Lv	I	H	M	N	Lv	I	H	M	N
30002	-					-					-				
30003	514	50	110	60	80	523.5	63	135	72	95	502.5	75	161	86	112.5
30004	575					584.5					563.5				

CHPL	CHM 90					CHM 110					CHM 130					
	Lv	I	H	M	N	Lv	I	H	M	N	Lv	I	H	M	N	
30002	-					455	110	237.5	127.5	160	462	130	277.5	147.5	180	
30003	512.5	90	193	103	129.5	540					547					
30004	573.5															

CHPL	CHM 150				
	Lv	I	H	M	N
30002	477				
30003	562	150	320	170	210
30004	-				

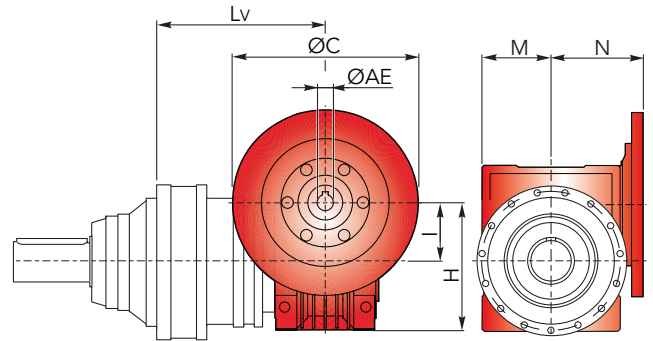

## CHPLB 30000 CMC - Flange motori IEC

## CHPLB 30000 CMC - IEC Motor flanges

CHPLB	IEC 63				IEC 71				IEC 80				IEC 90			
	L	LP	P	ØD	L	LP	P	ØD	L	LP	P	ØD	L	LP	P	ØD
30003	-				-				-				-			
30004	490	276	36	140	490	276	36	160	490	296	56	200	490	296	56	200

CHPLB	IEC 100				IEC 112				IEC 132				IEC 160				IEC 180							
	L	LP	P	ØD	L	LP	P	ØD	L	LP	P	ØD	L	LP	P	ØD	L	LP	P	ØD				
30003	-				-				-				452	433	118	350	452	433	118	350	-			
30004	490	306	66	250	490	306	66	250	490	340	100	300	490	379	139	350	-				-			

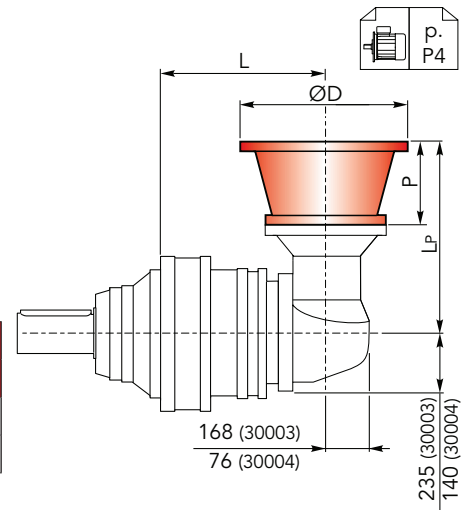

## CHPLB 30000 CMC - Alberi maschi entrata

## CHPL 30000 CMC - Male input shafts

CHPLB	CM42					CM65					CP65					
	L	Lt	T	Le	ØE	L	Lt	T	Le	ØE	L	Lt	T	Le	ØE	
30003	-					452	436.5	121.5	105	65 h6	452	468	153	105	65 h6	
30004	490	333	93	82	42 h6	490	377.5				490	409				

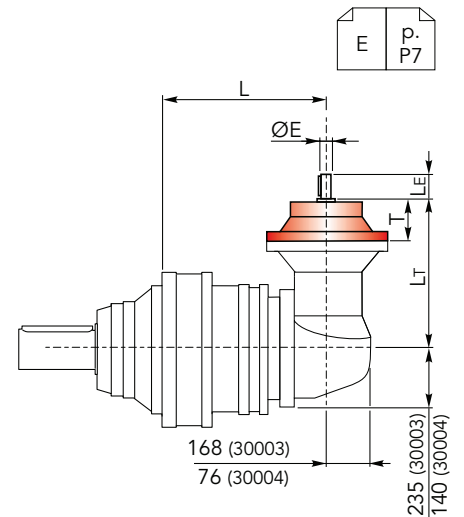



## DIMENSIONI CF

## CF DIMENSIONS

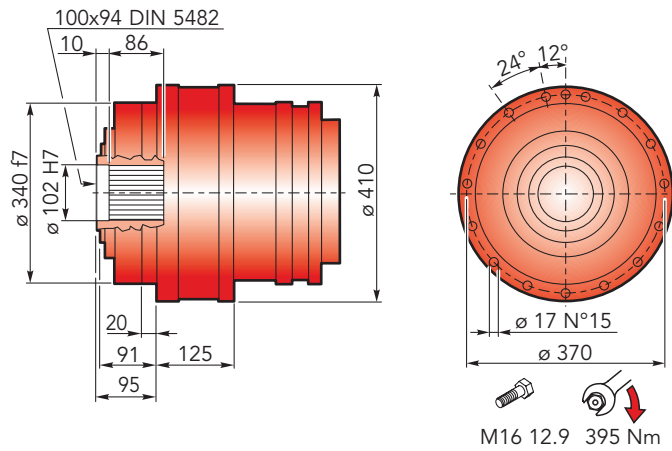

Accessori  
Accessories

CHKB

p.  
M14

## CHPL 30000 CF - Flange motori IEC

## CHPL 30000 CF- IEC Motor flanges

CHPL	IEC 63			IEC 71			IEC 80			IEC 90			IEC 100		
	LP	P	ØD	LP	P	ØD	LP	P	ØD	LP	P	ØD	LP	P	ØD
30002	-	-	-	-	-	-	-	-	-	-	-	-	-	-	-
30003	414.5	36	140	414.5	36	160	434.5	56	200	434.5	56	200	444.5	66	250
30004	475.5	-	-	475.5	-	-	495.5	-	-	495.5	-	-	505.5	-	-

CHPL	IEC 112			IEC 132			IEC 160			IEC 180			IEC 200		
	LP	P	ØD	LP	P	ØD	LP	P	ØD	LP	P	ØD	LP	P	ØD
30002	-	-	-	-	-	-	425	118	350	425	118	350	455	148	400
30003	444.5	66	250	478.5	100	300	517.5	139	350	517.5	139	350	-	-	-
30004	505.5	-	-	539.5	-	-	578.5	-	-	-	-	-	-	-	-

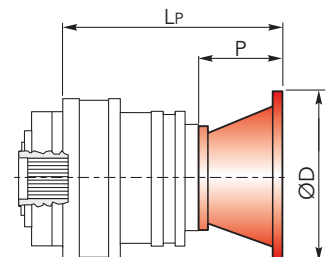

p.  
P4

## CHPL 30000 CF - Alberi maschi entrata

## CHPL 30000 CF - Male input shafts

CHPL	CM42				CM65				CP65			
	LT	T	LE	ØE	LT	T	LE	ØE	LT	T	LE	ØE
30002	-	-	-	-	428.5	121.5	105	65 h6	460	153	105	65 h6
30003	471.5	93	82	42 h6	513.5	-	-	-	545	-	-	-
30004	532.5	-	-	-	-	-	-	-	-	-	-	-

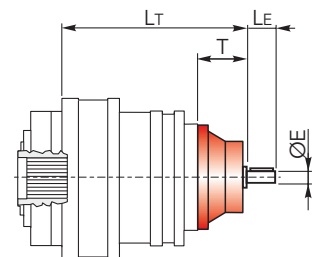

E  
p.  
P7



## DIMENSIONI CF

## CF DIMENSIONS

### CHPL 30000 CF - Riduttore a vite senza fine CHM in entrata

### CHPL 30000 CF - CHM input worm gearboxes

CHPL	CHM 50					CHM 63					CHM 75				
	Lv	I	H	M	N	Lv	I	H	M	N	Lv	I	H	M	N
30002	-					-					-				
30003	504	50	110	60	80	513.5	63	135	72	95	492.5	75	161	86	112.5
30004	565					574.5					553.5				

CHPL	CHM 90					CHM 110					CHM 130				
	Lv	I	H	M	N	Lv	I	H	M	N	Lv	I	H	M	N
30002	-					445	110	237.5	127.5	160	452	130	277.5	147.5	180
30003	502.5	90	193	103	129.5	530					537				
30004	563.5					-					-				

CHPL	CHM 150				
	Lv	I	H	M	N
30002	467				
30003	552	150	320	170	210
30004	-				

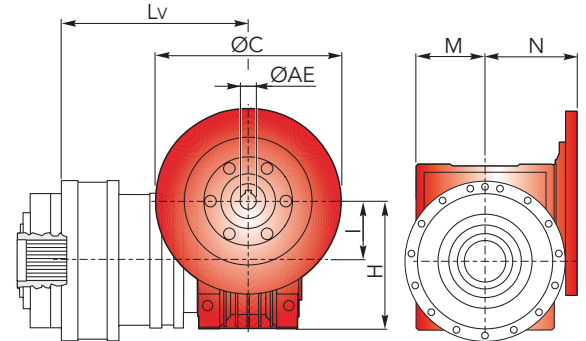

### CHPLB 30000 CF - Flange motori IEC

### CHPLB 30000 CF - IEC Motor flanges

CHPLB	IEC 63				IEC 71				IEC 80				IEC 90			
	L	Lp	P	ØD	L	Lp	P	ØD	L	Lp	P	ØD	L	Lp	P	ØD
30003	-				-				-				-			
30004	480	276	36	140	480	276	36	160	480	296	56	200	480	296	56	200

CHPLB	IEC 100				IEC 112				IEC 132				IEC 160				IEC 180							
	L	Lp	P	ØD	L	Lp	P	ØD	L	Lp	P	ØD	L	Lp	P	ØD	L	Lp	P	ØD				
30003	-				-				-				442	433	118	350	442	433	118	350	-			
30004	480	306	66	250	480	306	66	250	480	340	100	300	480	379	139	350	-				-			

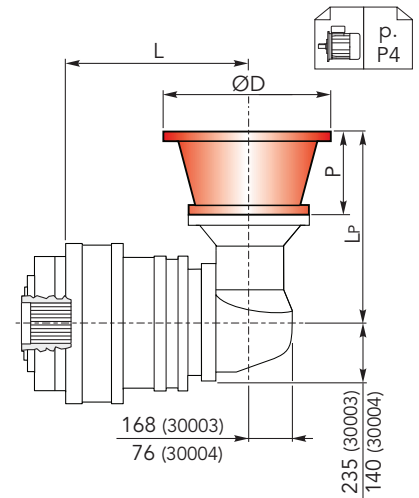

### CHPLB 30000 CF - Alberi maschi entrata

### CHPL 30000 CF - Male input shafts

CHPLB	CM42					CM65					CP65				
	L	Lt	T	Le	ØE	L	Lt	T	Le	ØE	L	Lt	T	Le	ØE
30003	-					442	436.5	121.5	105	65 h6	442	468	153	105	65 h6
30004	480	333	93	82	42 h6	480	377.5				480	409			

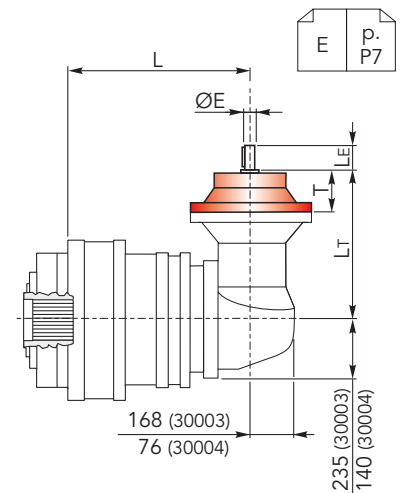



## DIMENSIONI CFS

## CFS DIMENSIONS

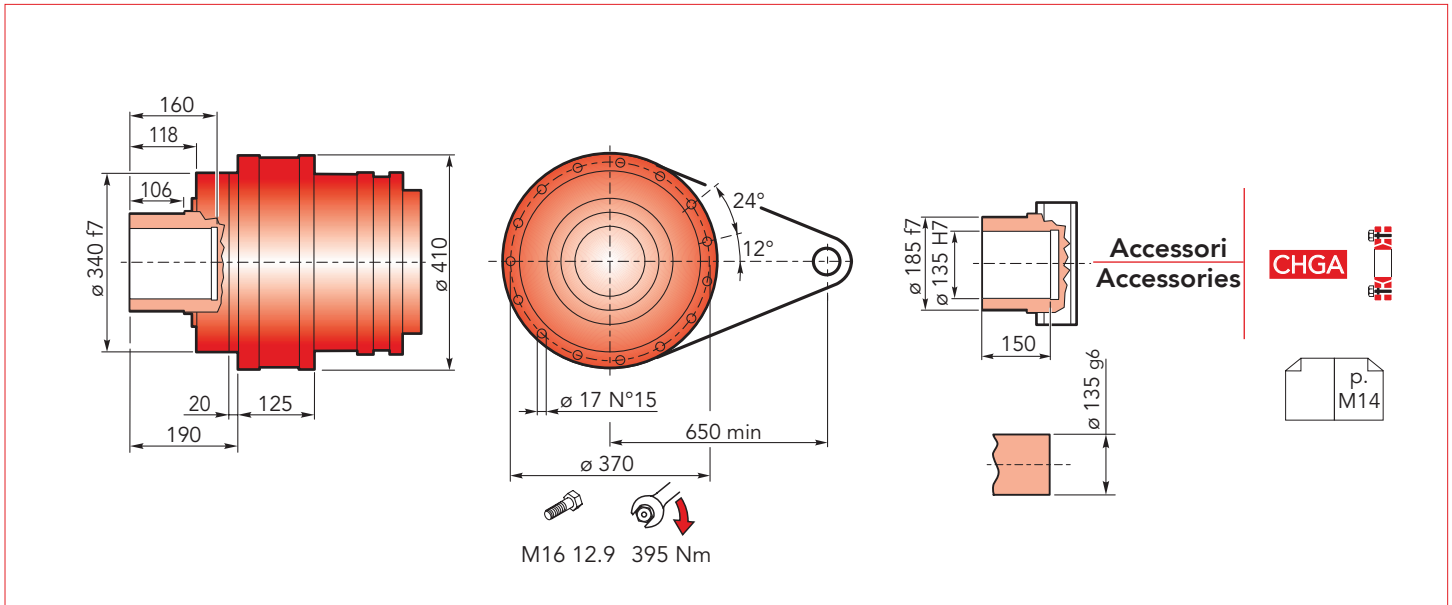

## CHPL 30000 CFS - Flange motori IEC

## CHPL 30000 CFS- IEC Motor flanges

CHPL	IEC 63			IEC 71			IEC 80			IEC 90			IEC 100		
	LP	P	ØD	LP	P	ØD	LP	P	ØD	LP	P	ØD	LP	P	ØD
30002	-	-	-	-	-	-	-	-	-	-	-	-	-	-	-
30003	414.5	36	140	414.5	36	160	434.5	56	200	434.5	56	200	444.5	66	250
30004	475.5	-	-	475.5	-	-	495.5	-	-	495.5	-	-	505.5	-	-

CHPL	IEC 112			IEC 132			IEC 160			IEC 180			IEC 200		
	LP	P	ØD	LP	P	ØD	LP	P	ØD	LP	P	ØD	LP	P	ØD
30002	-	-	-	-	-	-	425	118	350	425	118	350	455	148	400
30003	444.5	66	250	478.5	100	300	517.5	139	-	517.5	139	-	-	-	-
30004	505.5	-	-	539.5	-	-	578.5	-	-	-	-	-	-	-	-

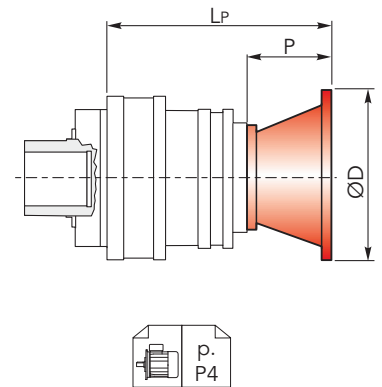

## CHPL 30000 CFS - Alberi maschi entrata

## CHPL 30000 CFS - Male input shafts

CHPL	CM42				CM65				CP65			
	LT	T	LE	ØE	LT	T	LE	ØE	LT	T	LE	ØE
30002	-	-	-	-	428.5	121.5	105	65 h6	460	153	105	65 h6
30003	471.5	93	82	42 h6	513.5	-	-	-	545	-	-	-
30004	532.5	-	-	-	-	-	-	-	-	-	-	-

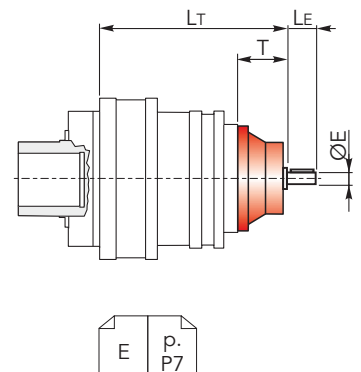



## DIMENSIONI CFS

## CFS DIMENSIONS

CHPL/CHPLB 30000

CHPL 30000 CFS - Riduttore a vite senza fine CHM in entrata CHPL 30000 CFS - CHM input worm gearboxes

CHPL	CHM 50					CHM 63					CHM 75				
	Lv	I	H	M	N	Lv	I	H	M	N	Lv	I	H	M	N
30002	-					-					-				
30003	504	50	110	60	80	513.5	63	135	72	95	492.5	75	161	86	112.5
30004	565					574.5					553.5				

CHPL	CHM 90					CHM 110					CHM 130					
	Lv	I	H	M	N	Lv	I	H	M	N	Lv	I	H	M	N	
30002	-					445	110	237.5	127.5	160	452	130	277.5	147.5	180	
30003	502.5	90	193	103	129.5	530					537					
30004	563.5															

CHPL	CHM 150				
	Lv	I	H	M	N
30002	467				
30003	552	150	320	170	210
30004	-				

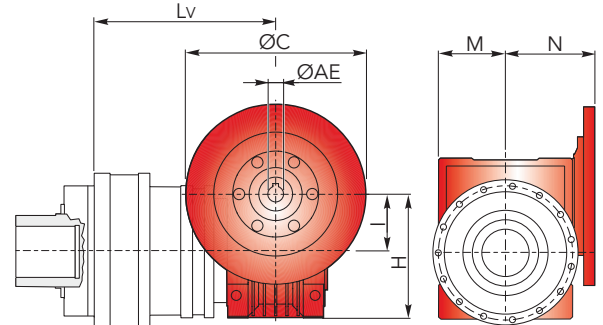

CHPLB 30000 CFS - Flange motori IEC

CHPLB 30000 CFS - IEC Motor flanges

CHPLB	IEC 63				IEC 71				IEC 80				IEC 90			
	L	LP	P	ØD	L	LP	P	ØD	L	LP	P	ØD	L	LP	P	ØD
30003	-				-				-				-			
30004	480	276	36	140	480	276	36	160	480	296	56	200	480	296	56	200

CHPLB	IEC 100				IEC 112				IEC 132				IEC 160				IEC 180					
	L	LP	P	ØD	L	LP	P	ØD	L	LP	P	ØD	L	LP	P	ØD	L	LP	P	ØD		
30003	-				-				-				442	433	118	350	442	433	118	350		
30004	480	306	66	250	480	306	66	250	480	340	100	300	480	379	139	350						

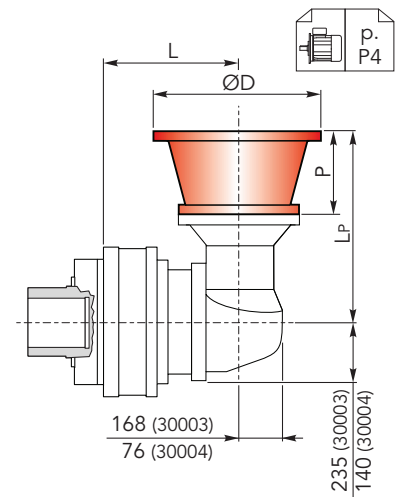

CHPLB 30000 CFS - Alberi maschi entrata

CHPL 30000 CFS - Male input shafts

CHPLB	CM42					CM65					CP65				
	L	Lt	T	Le	ØE	L	Lt	T	Le	ØE	L	Lt	T	Le	ØE
30003	-					442	436.5	121.5	105	65 h6	442	468	153	105	65 h6
30004	480	333	93	82	42 h6	480	377.5				480	409			

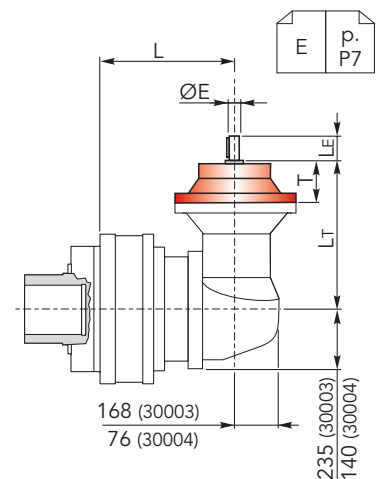



## DIMENSIONI CCPC

## CCPC DIMENSIONS

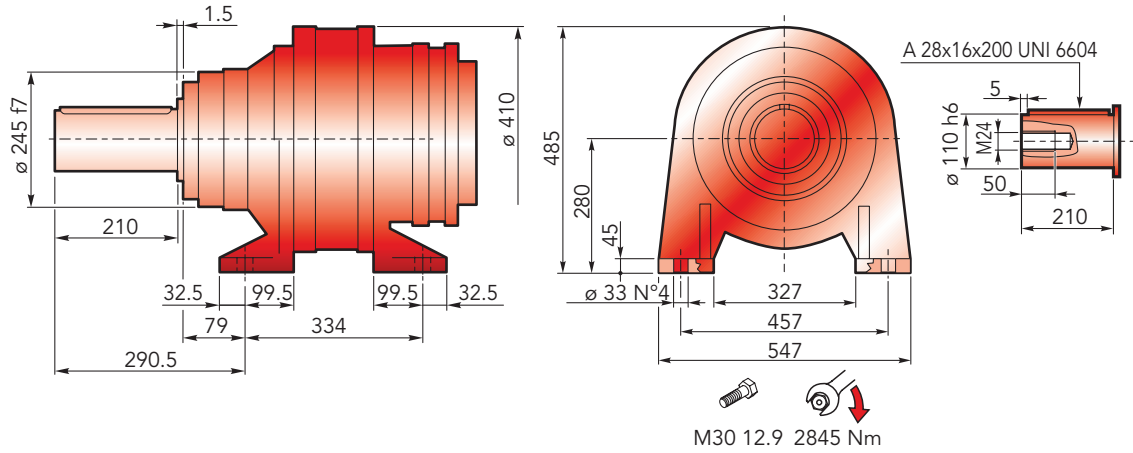

## CHPL 30000 CCPC - Flange motori IEC

## CHPL 30000 CCPC- IEC Motor flanges

CHPL	IEC 63			IEC 71			IEC 80			IEC 90			IEC 100		
	L <sub>P</sub>	P	ØD	L <sub>P</sub>	P	ØD	L <sub>P</sub>	P	ØD	L <sub>P</sub>	P	ØD	L <sub>P</sub>	P	ØD
30002	-	-	-	-	-	-	-	-	-	-	-	-	-	-	-
30003	604.5	36	140	604.5	36	160	624.5	56	200	624.5	56	200	634.5	66	250
30004	665.5	-	-	665.5	-	-	685.5	-	-	685.5	-	-	695.5	-	-

CHPL	IEC 112			IEC 132			IEC 160			IEC 180			IEC 200		
	L <sub>P</sub>	P	ØD	L <sub>P</sub>	P	ØD	L <sub>P</sub>	P	ØD	L <sub>P</sub>	P	ØD	L <sub>P</sub>	P	ØD
30002	-	-	-	-	-	-	615	118	350	615	118	350	645	148	400
30003	634.5	66	250	668.5	100	300	707.5	139	350	707.5	139	350	-	-	-
30004	695.5	-	-	729.5	-	-	768.5	-	-	-	-	-	-	-	-

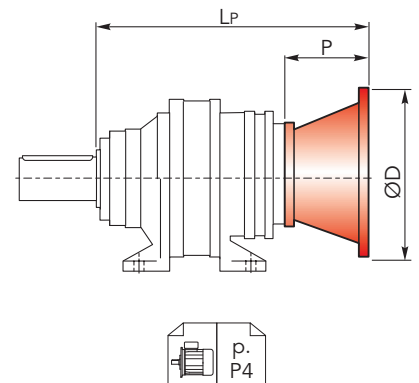

## CHPL 30000 CCPC - Alberi maschi entrata

## CHPL 30000 CCPC - Male input shafts

CHPL	CM42				CM65				CP65			
	L <sub>T</sub>	T	L <sub>E</sub>	ØE	L <sub>T</sub>	T	L <sub>E</sub>	ØE	L <sub>T</sub>	T	L <sub>E</sub>	ØE
30002	-	-	-	-	618.5	121.5	105	65 h6	650	153	105	65 h6
30003	661.5	93	82	42 h6	703.5	-	-	-	735	-	-	-
30004	722.5	-	-	-	-	-	-	-	-	-	-	-

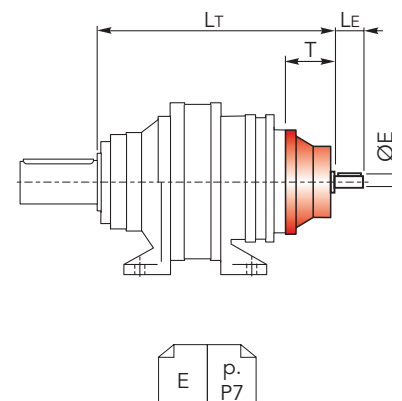



## DIMENSIONI CCPC

## CCPC DIMENSIONS

CHPL/CHPLB 30000

CHPL 30000 CCPC - Riduttore a vite senza fine CHM in entrata CHPL 30000 CCPC - CHM input worm gearboxes

CHPL	CHM 50					CHM 63					CHM 75				
	Lv	I	H	M	N	Lv	I	H	M	N	Lv	I	H	M	N
30002	-					-					-				
30003	694	50	110	60	80	703.5	63	135	72	95	682.5	75	161	86	112.5
30004	755					764.5					743.5				

CHPL	CHM 90					CHM 110					CHM 130				
	Lv	I	H	M	N	Lv	I	H	M	N	Lv	I	H	M	N
30002	-					635	110	237.5	127.5	160	642	130	277.5	147.5	180
30003	692.5	90	193	103	129.5	720					727				
30004	753.5														

CHPL	CHM 150				
	Lv	I	H	M	N
30002	657	150	320	170	210
30003	742				
30004	-				

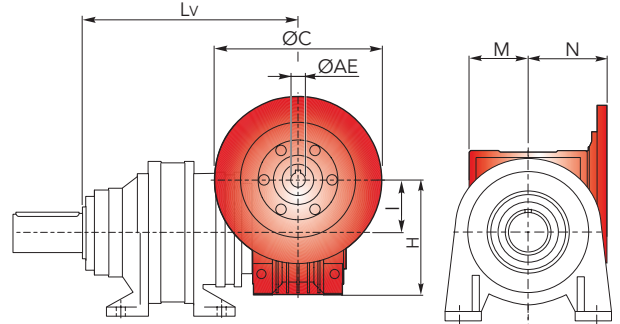

CHPLB 30000 CCPC - Flange motori IEC

CHPLB 30000 CCPC - IEC Motor flanges

CHPLB	IEC 63				IEC 71				IEC 80				IEC 90			
	L	LP	P	ØD	L	LP	P	ØD	L	LP	P	ØD	L	LP	P	ØD
30003	-				-				-				-			
30004	670	276	36	140	670	276	36	160	670	296	56	200	670	296	56	200

CHPLB	IEC 100				IEC 112				IEC 132				IEC 160				IEC 180							
	L	LP	P	ØD	L	LP	P	ØD	L	LP	P	ØD	L	LP	P	ØD	L	LP	P	ØD				
30003	-				-				-				632	433	118	350	632	433	118	350	-			
30004	670	306	66	250	670	306	66	250	670	340	100	300	670	379	139									

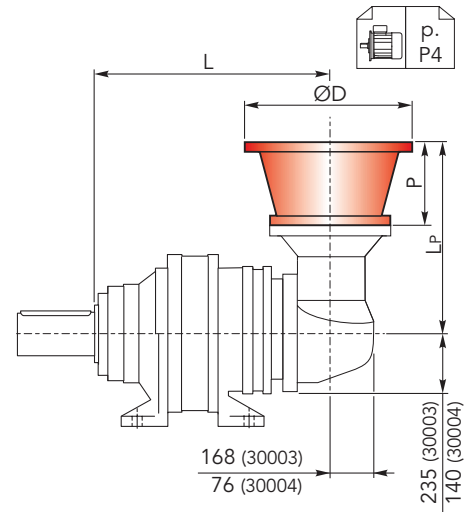

CHPLB 30000 CCPC - Alberi maschi entrata

CHPL 30000 CCPC - Male input shafts

CHPLB	CM42					CM65					CP65				
	L	Lt	T	Le	ØE	L	Lt	T	Le	ØE	L	Lt	T	Le	ØE
30003	-					632	436.5	121.5	105	65 h6	632	468	153	105	65 h6
30004	670	333	93	82	42 h6	670	377.5				670	409			

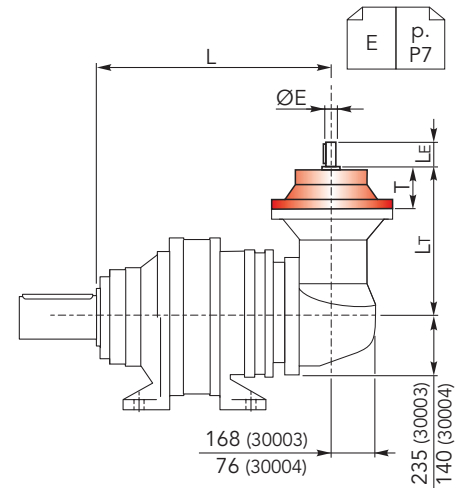



## ACCESSORI

## ACCESSORIES

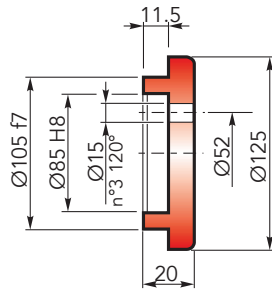
**CHFF**  **Fondello di arresto / Stop bottom plate**

Codice / Code:  
1075.042.000

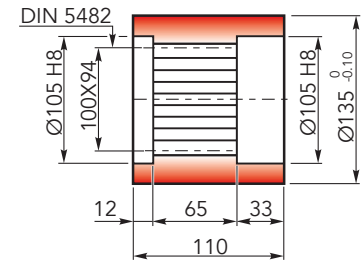
**CHBS**  **Boccola scanalata / Splined bushing**

Codice / Code:  
8171.112.041

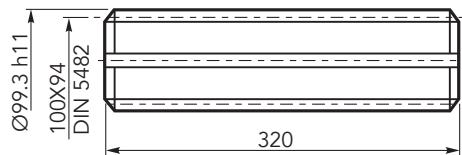
**CHKB**  **Barra scanalata / Splined rod**

Codice / Code:  
3071.407.042

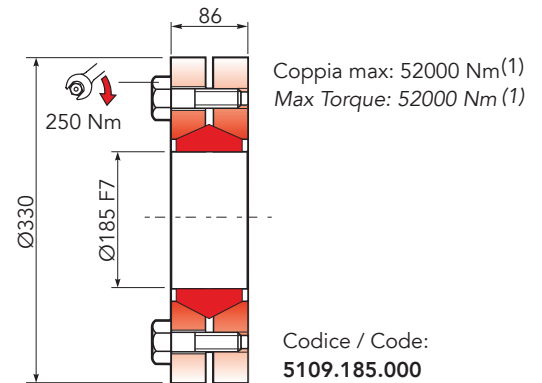
**CHGA**  **Giunto di attrito / Shrink disc**

(1): Coppia max indicata è valida solo con calettatori forniti da Chiaravalli S.p.A.

(1): The maximum torque indicated is valid only with shrink discs supplied by Chiaravalli S.p.A.

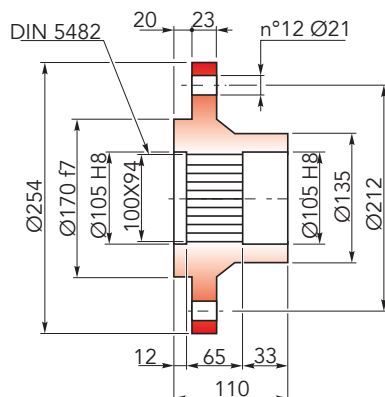
**CHFL**  **Flangia / Flange**

Codice / Code:  
8171.104.098





## CARICHI RADIALI (Fr)

## RADIAL LOADS (Fr)

Nel diagramma seguente, sono indicati i carichi radiali  $F_r$  (N) applicabili sull'albero uscita in funzione della distanza di applicazione  $L$  rispetto alla battuta dell'albero.

The hereunder table shows the allowable radial loads  $F_r$  (N) on the output shaft with reference to the distance  $L$ .

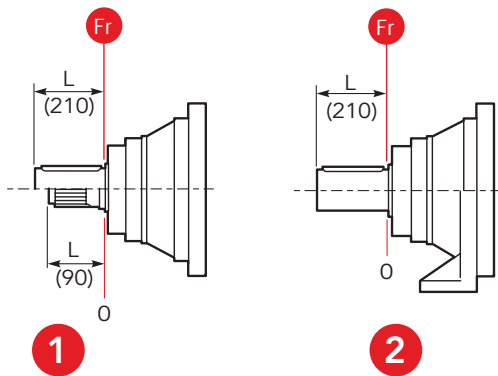
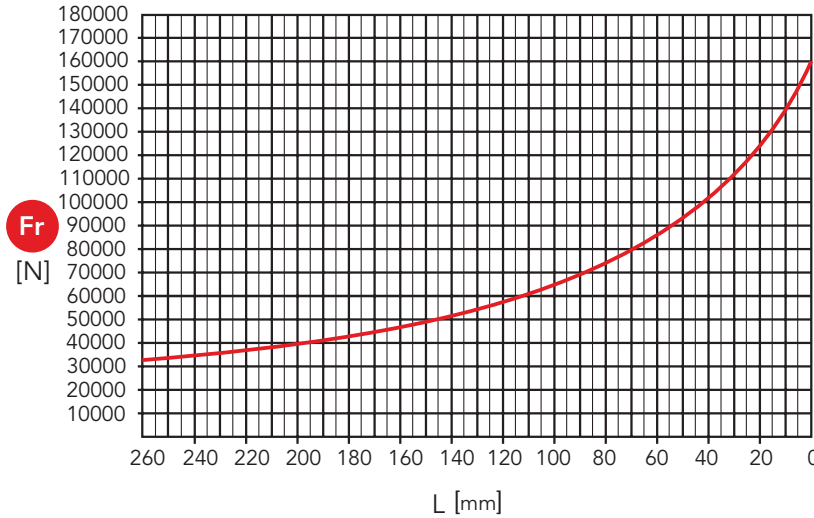

- 1 Uscita / Output: CMS, CMC
- 2 Uscita / Output: CCPC

## CARICHI ASSIALI (Fa)

## AXIAL LOADS (Fa)

Nella tabella seguente sono indicati i carichi assiali  $F_a$  (N) applicabili sull'albero di uscita in funzione della direzione di applicazione del carico e della versione.

The hereunder table shows the allowable axial loads  $F_a$  (N) on the output shaft with reference to the load direction and the output type.

	1	2	
$F_a$ [N]	75000	75000	←
	95000	95000	→

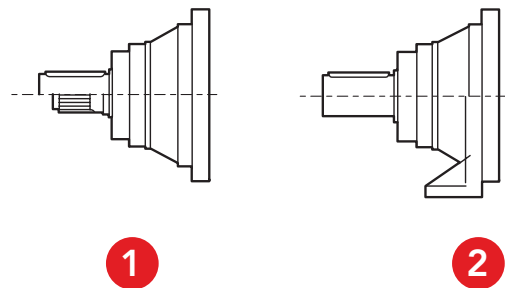





- 1 Uscita / Output: CMS, CMC
- 2 Uscita / Output: CCPC



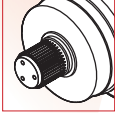

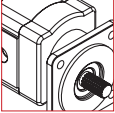
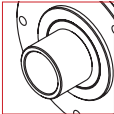
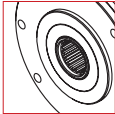
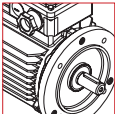
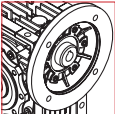
# CHPL/CHPLB 35000

	<b>i</b>	<b>T<sub>2n</sub></b> (daNm)	<b>OUT</b>		<b>IN</b>	
<b>35001</b>	4.00 ÷ 4.71	2332.3 ÷ 2737.9	 Ø120	 W120X3X38X8f DIN 5480	 Ø42 Ø65	 Hydraulic Motor
<b>35002</b>	14.2 ÷ 27.0	2332.3 ÷ 2737.9	 Ø135	 N120X5X22X9H DIN 5480	 Electric Motor	 Worm gearboxes
<b>35003</b>	53.7 ÷ 230.3	2332.3 ÷ 2737.9				
<b>35004</b>	191.0 ÷ 1289.7	2332.3 ÷ 2737.9			 Brake	

**CHPL**

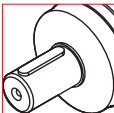
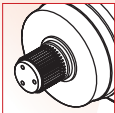
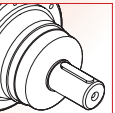
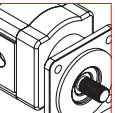
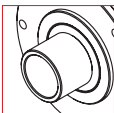
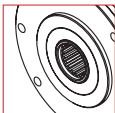
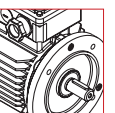
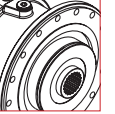

	<b>i</b>	<b>T<sub>2n</sub></b> (daNm)	<b>OUT</b>		<b>IN</b>	
<b>35002</b>	12.3 ÷ 22.0	2332.3 ÷ 2737.9	 Ø120	 W120X3X38X8f DIN 5480	 Ø42 Ø65	 Hydraulic Motor
<b>35003</b>	43.7 ÷ 123.0	2332.3 ÷ 2737.9	 Ø135	 N120X5X22X9H DIN 5480	 Electric Motor	
<b>35004</b>	185.6 ÷ 1253.8	2332.3 ÷ 2737.9			 Brake	

**CHPLB**

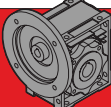

## DATI TECNICI

## TECHNICAL DATA



 CHPL	i	T <sub>2n</sub> (n <sub>1</sub> =1400 rpm) [daNm]	P <sub>1n</sub> (n <sub>1</sub> =1400 rpm) [kW]	P <sub>t</sub> [kW]	IEC (B5)	 CHM	 CM / CP
<b>35001</b>	4	2737.9	1003	54	160   180	-	-
	4.71	2332.3	726		200   225		
<b>35002</b>	14.2	2737.9	283	34	160   180	CHM 110 CHM 130 CHM 150	CM65 CP65
	17.1	2737.9	235				
	20.2	2332.3	169				
	22.4	2737.9	179				
	27	2332.3	127				
<b>35003</b>	53.7	2737.9	75	23	63   71 80   90 100   112 132   160	CHM 50 CHM 63 CHM 75 CHM 90 CHM 110 CHM 130 CHM 150	CM42 CM65 CP65
	58.7	2737.9	68				
	64.8	2737.9	62				
	70.7	2737.9	57				
	83.2	2332.3	41				
	88.6	2737.9	45				
	99.6	2332.3	34				
	108.7	2332.3	31				
	121	2332.3	28				
	136.2	2332.3	25				
	158.1	2332.3	22				
	164.1	2332.3	21				
	191.1	2332.3	18				
230.3	2332.3	15					
<b>35004</b>	191	2737.9	21	17	63   71 80   90 100   112 132   160	CHM 50 CHM 63 CHM 75 CHM 90	CM42
	208.6	2737.9	19				
	230.3	2737.9	17				
	251.4	2737.9	16				
	277.5	2737.9	14				
	303.1	2737.9	13				
	328.5	2737.9	12				
	362.7	2737.9	11				
	379.6	2737.9	11				
	437.1	2737.9	9.2				
	496	2737.9	8.1				
	583.5	2332.3	5.9				
	677.7	2332.3	5.0				
	703.4	2332.3	4.9				
	762.5	2332.3	4.5				
816.8	2332.3	4.2					
987	2332.3	3.5					
1067.3	2332.3	3.2					
1289.7	2332.3	2.7					

n<sub>1max</sub> = 2800 rpmSolo per / Only for CHPL 35001: n<sub>1max</sub> = 1500 rpmSolo per / Only for CHPL 35002: n<sub>1max</sub> = 2000 rpm

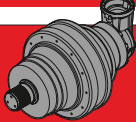

## DATI TECNICI

## TECHNICAL DATA

 CHPLB	i	T <sub>2n</sub> (n <sub>1</sub> =1400 rpm)	P <sub>1n</sub> (n <sub>1</sub> =1400 rpm)	P <sub>t</sub>	IEC	 CM / CP
		[daNm]	[kW]	[kW]	(B5)	
<b>35002</b>	12.3	2737.9	326	34	160   180 200	CM65 CP65
	14.5	2332.3	236			
	18.7	2737.9	215			
	22	2332.3	155			
<b>35003</b>	43.7	2737.9	92	23	160   180	CM65 CP65
	52.7	2737.9	76			
	66.4	2737.9	60			
	80	2737.9	50			
	94.1	2332.3	36			
	123	2332.3	28			
<b>35004</b>	185.6	2737.9	22	17	63   71 80   90 100   112 132   160	CM42 CM65 CP65
	202.7	2737.9	20			
	223.7	2737.9	18			
	244.3	2737.9	16			
	292.5	2737.9	14			
	319.4	2737.9	13			
	352.6	2737.9	11			
	385	2737.9	10			
	414.8	2332.3	8.2			
	452.9	2332.3	7.5			
	542	2332.3	6.3			
	591.8	2332.3	5.8			
	658.8	2332.3	5.2			
	741.3	2332.3	4.6			
	860.9	2332.3	4.0			
1037.7	2332.3	3.3				
1253.8	2332.3	2.7				

n<sub>1max</sub> = 2800 rpmSolo per / Only for CHPLB 35002: n<sub>1max</sub> = 2000 rpm



## DIMENSIONI CMS

## CMS DIMENSIONS

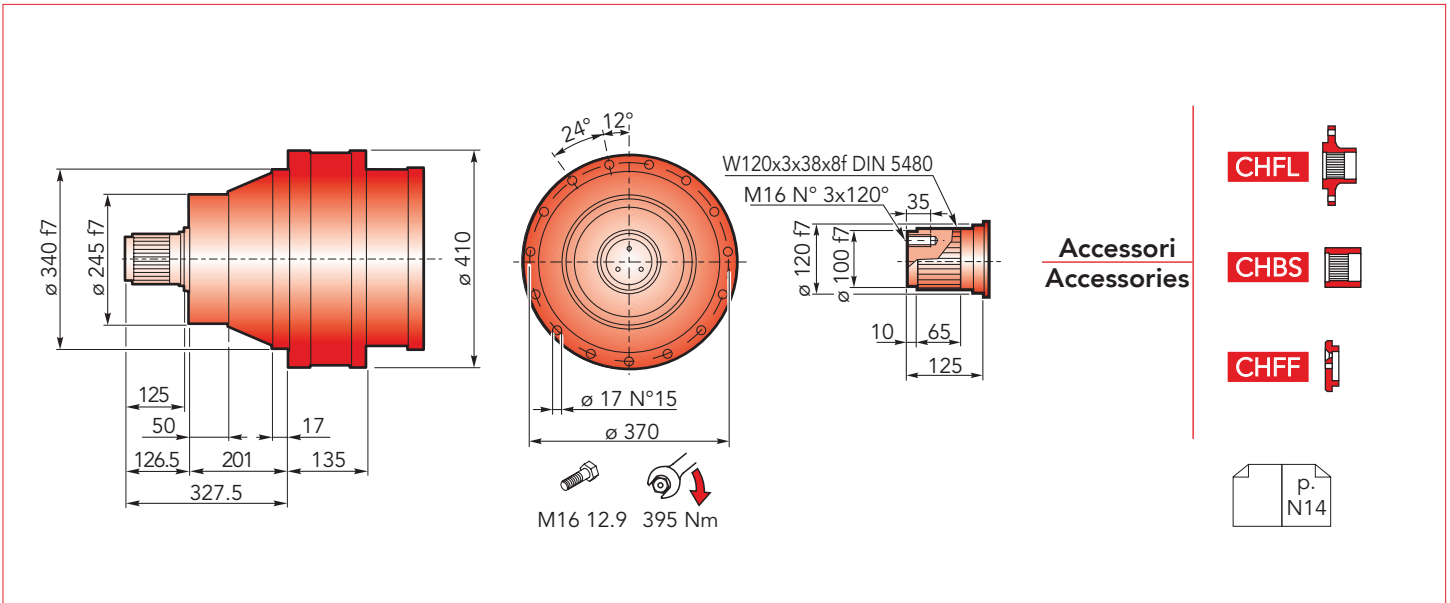

### CHPL 35000 CMS - Flange motori IEC

### CHPL 35000 CMS- IEC Motor flanges

CHPL	IEC 63			IEC 71			IEC 80			IEC 90			IEC 100			IEC 112		
	Lp	P	ØD	Lp	P	ØD	Lp	P	ØD	Lp	P	ØD	Lp	P	ØD	Lp	P	ØD
35001	-	-	-	-	-	-	-	-	-	-	-	-	-	-	-	-	-	-
35002	-	-	-	-	-	-	-	-	-	-	-	-	-	-	-	-	-	-
35003	424.5	36	140	424.5	36	160	444.5	56	200	444.5	56	200	454.5	66	250	454.5	66	250
35004	485.5	-	-	485.5	-	-	505.5	-	-	505.5	-	-	515.5	-	-	515.5	-	-

CHPL	IEC 132			IEC 160			IEC 180			IEC 200			IEC 225			IEC 250		
	Lp	P	ØD	Lp	P	ØD	Lp	P	ØD	Lp	P	ØD	Lp	P	ØD	Lp	P	ØD
35001	-	-	-	380	150	-	380	150	-	380	150	400	369	139	450	369	139	550
35002	-	-	-	435	118	350	435	118	350	465	148	-	-	-	-	-	-	-
35003	488.5	100	300	527.5	139	-	527.5	139	-	-	-	-	-	-	-	-	-	-
35004	549.5	-	-	588.5	-	-	-	-	-	-	-	-	-	-	-	-	-	-

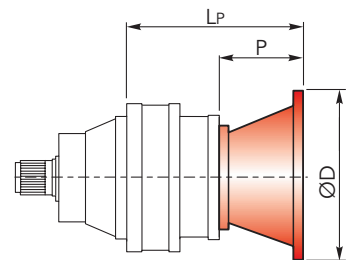

p. P4

### CHPL 35000 CMS - Alberi maschi entrata

### CHPL 35000 CMS - Male input shafts

CHPL	CM42				CM65				CP65			
	Lt	T	Le	ØE	Lt	T	Le	ØE	Lt	T	Le	ØE
35001	-	-	-	-	-	-	-	-	-	-	-	-
35002	-	-	-	-	438.5	121.5	105	65 h6	470	153	105	65 h6
35003	481.5	93	82	42 h6	523.5	-	-	-	555	-	-	-
35004	542.5	-	-	-	-	-	-	-	-	-	-	-

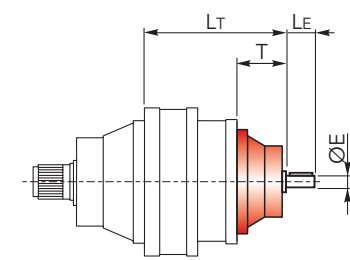

E p. P7



## DIMENSIONI CMS

## CMS DIMENSIONS

CHPL/CHPLB 35000

CHPL 35000 CMS - Riduttore a vite senza fine CHM in entrata

CHPL 35000 CMS - CHM input worm gearboxes

CHPL	CHM 50					CHM 63					CHM 75				
	Lv	I	H	M	N	Lv	I	H	M	N	Lv	I	H	M	N
35001	-					-					-				
35002	-					-					-				
35003	514	50	110	60	80	523.5	63	135	72	95	502.5	75	161	86	112.5
35004	575					584.5					563.5				

CHPL	CHM 90					CHM 110					CHM 130				
	Lv	I	H	M	N	Lv	I	H	M	N	Lv	I	H	M	N
35001	-					-					-				
35002	-					455					462				
35003	512.5					540	110	237.5	127.5	160	547	130	277.5	147.5	180
35004	573.5	90	193	103	129.5										

CHPL	CHM 150				
	Lv	I	H	M	N
35001	-				
35002	477				
35003	562	150	320	170	210
35004	-				

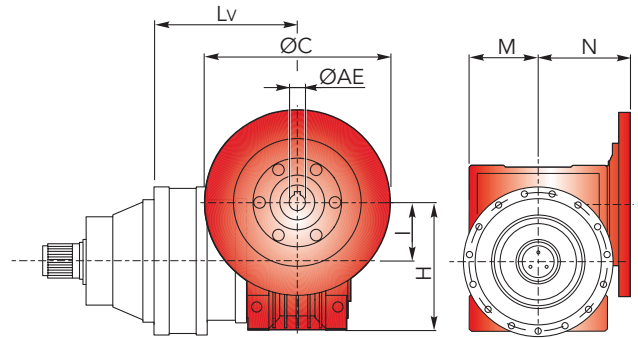

$\begin{matrix} \text{ØC} & \text{p.} \\ \text{ØAE} & \text{P6} \end{matrix}$

CHPLB 35000 CMS - Flange motori IEC

CHPLB 35000 CMS - IEC Motor flanges

CHPLB	IEC 63				IEC 71				IEC 80				IEC 90				IEC 100			
	L	Lp	P	ØD	L	Lp	P	ØD	L	Lp	P	ØD	L	Lp	P	ØD	L	Lp	P	ØD
35002	-				-				-				-				-			
35003	-				-				-				-				-			
35004	490	276	36	140	490	276	36	160	490	296	56	200	490	296	56	200	490	306	66	250

CHPLB	IEC 112				IEC 132				IEC 160				IEC 180				IEC 200			
	L	Lp	P	ØD	L	Lp	P	ØD	L	Lp	P	ØD	L	Lp	P	ØD	L	Lp	P	ØD
35002	-				-				295	433	118		295	433	118	350	295	463	148	400
35003	-				-				452			350	452				-			
35004	490	306	66	250	490	340	66	300	490	379	139		-				-			

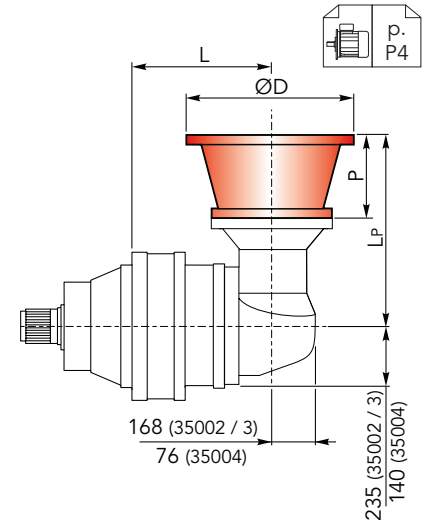

CHPLB 35000 CMS - Alberi maschi entrata

CHPL 35000 CMS - Male input shafts

CHPLB	CM42					CM65					CP65				
	L	Lt	T	Le	ØE	L	Lt	T	Le	ØE	L	Lt	T	Le	ØE
35002	-					295	436.5				295	468			
35003	-					452		121.5	105	65 h6	452		153	105	65 h6
35004	490	333	93	82	42 h6	490	377.5				490	409			

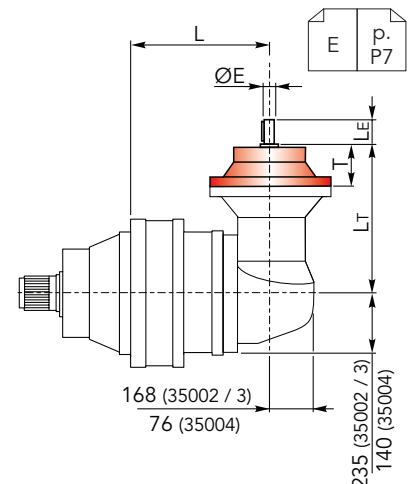



## DIMENSIONI CMC

## CMC DIMENSIONS

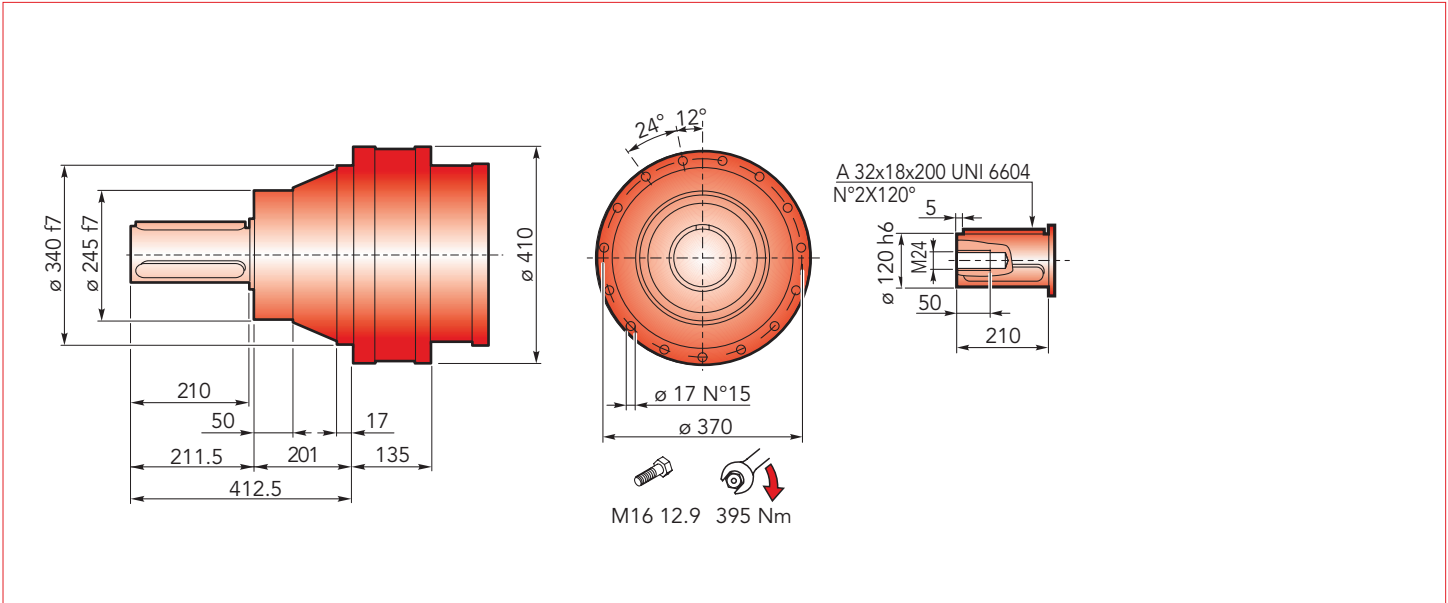

### CHPL 35000 CMC - Flange motori IEC

### CHPL 35000 CMC- IEC Motor flanges

CHPL	IEC 63			IEC 71			IEC 80			IEC 90			IEC 100			IEC 112		
	LP	P	ØD	LP	P	ØD	LP	P	ØD	LP	P	ØD	LP	P	ØD	LP	P	ØD
35001	-	-	-	-	-	-	-	-	-	-	-	-	-	-	-	-	-	-
35002	-	-	-	-	-	-	-	-	-	-	-	-	-	-	-	-	-	-
35003	424.5	36	140	424.5	36	160	444.5	56	200	444.5	56	200	454.5	66	250	454.5	66	250
35004	485.5	36	140	485.5	36	160	505.5	56	200	505.5	56	200	515.5	66	250	515.5	66	250

CHPL	IEC 132			IEC 160			IEC 180			IEC 200			IEC 225			IEC 250		
	LP	P	ØD	LP	P	ØD	LP	P	ØD	LP	P	ØD	LP	P	ØD	LP	P	ØD
35001	-	-	-	380	150	-	380	150	-	380	150	400	369	139	450	369	139	550
35002	-	-	-	435	118	350	435	118	350	465	148	400	-	-	-	-	-	-
35003	488.5	100	300	527.5	139	350	527.5	139	350	-	-	-	-	-	-	-	-	-
35004	549.5	100	300	588.5	139	350	-	-	-	-	-	-	-	-	-	-	-	-

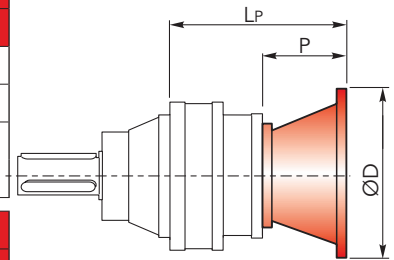

### CHPL 35000 CMC - Alberi maschi entrata

### CHPL 35000 CMC - Male input shafts

CHPL	CM42				CM65				CP65			
	LT	T	LE	ØE	LT	T	LE	ØE	LT	T	LE	ØE
35001	-	-	-	-	-	-	-	-	-	-	-	-
35002	-	-	-	-	438.5	121.5	105	65 h6	470	153	105	65 h6
35003	481.5	93	82	42 h6	523.5	121.5	105	65 h6	555	153	105	65 h6
35004	542.5	93	82	42 h6	-	-	-	-	-	-	-	-

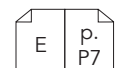
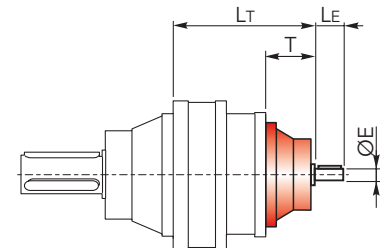





## DIMENSIONI CMC

## CMC DIMENSIONS

CHPL/CHPLB 35000

CHPL 35000 CMC - Riduttore a vite senza fine CHM in entrata CHPL 35000 CMC - CHM input worm gearboxes

CHPL	CHM 50					CHM 63					CHM 75				
	Lv	I	H	M	N	Lv	I	H	M	N	Lv	I	H	M	N
35001	-					-					-				
35002	-					-					-				
35003	514	50	110	60	80	523.5	63	135	72	95	502.5	75	161	86	112.5
35004	575					584.5					563.5				

CHPL	CHM 90					CHM 110					CHM 130				
	Lv	I	H	M	N	Lv	I	H	M	N	Lv	I	H	M	N
35001	-					-					-				
35002	-					455					462				
35003	512.5					540	110	237.5	127.5	160	547	130	277.5	147.5	180
35004	573.5	90	193	103	129.5										

CHPL	CHM 150				
	Lv	I	H	M	N
35001	-				
35002	477				
35003	562	150	320	170	210
35004	-				

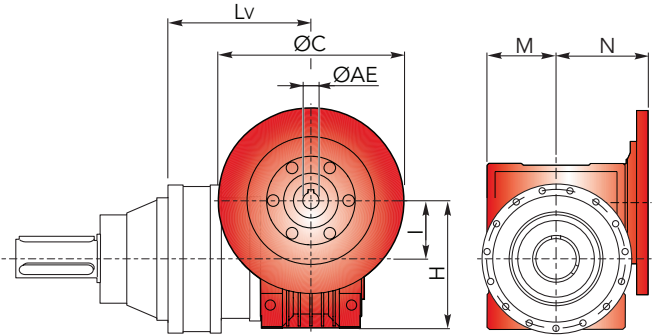

## CHPLB 35000 CMC - Flange motori IEC

## CHPLB 35000 CMC - IEC Motor flanges

CHPLB	IEC 63				IEC 71				IEC 80				IEC 90				IEC 100			
	L	Lp	P	ØD	L	Lp	P	ØD	L	Lp	P	ØD	L	Lp	P	ØD	L	Lp	P	ØD
35002	-				-				-				-				-			
35003	-				-				-				-				-			
35004	490	276	36	140	490	276	36	160	490	296	56	200	490	296	56	200	490	306	66	250

CHPLB	IEC 112				IEC 132				IEC 160				IEC 180				IEC 200			
	L	Lp	P	ØD	L	Lp	P	ØD	L	Lp	P	ØD	L	Lp	P	ØD	L	Lp	P	ØD
35002	-				-				295	433	118		295	433	118	350	295	463	148	400
35003	-				-				452			350	452				-			
35004	490	306	66	250	490	340	66	300	490	379	139		-				-			

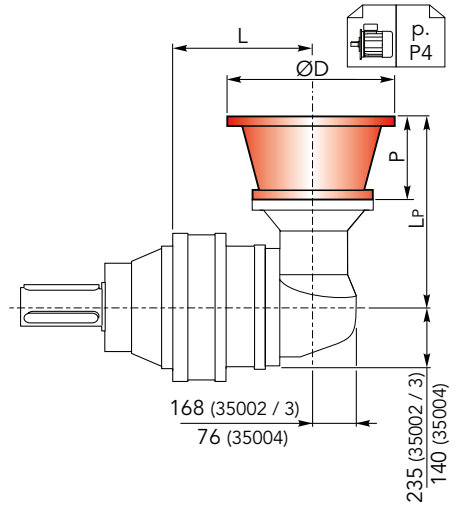

## CHPLB 35000 CMC - Alberi maschi entrata

## CHPL 35000 CMC - Male input shafts

CHPLB	CM42					CM65					CP65				
	L	Lt	T	Le	ØE	L	Lt	T	Le	ØE	L	Lt	T	Le	ØE
35002	-					295	436.5				295	468			
35003	-					452		121.5	105	65 h6	452		153	105	65 h6
35004	490	333	93	82	42 h6	490	377.5				490	409			

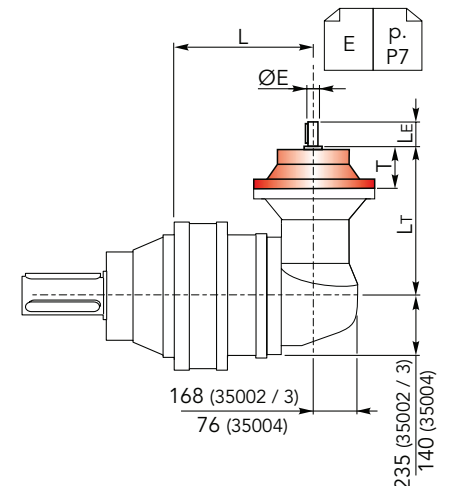



**DIMENSIONI CF**

**CF DIMENSIONS**

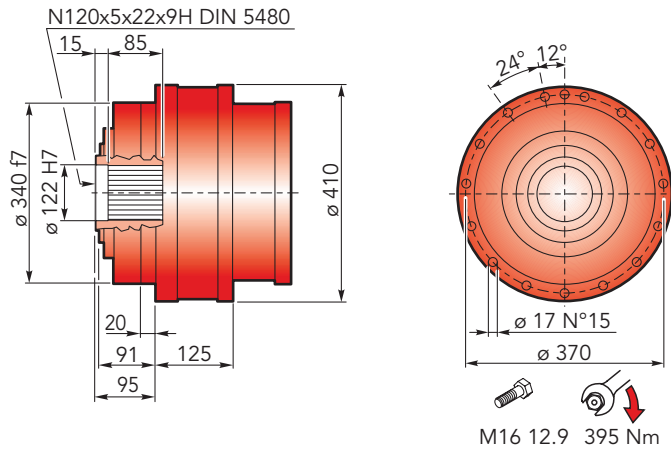

Accessori  
Accessories



**CHPL 35000 CF - Flange motori IEC**

**CHPL 35000 CF- IEC Motor flanges**

CHPL	IEC 63			IEC 71			IEC 80			IEC 90			IEC 100			IEC 112		
	LP	P	ØD	LP	P	ØD	LP	P	ØD	LP	P	ØD	LP	P	ØD	LP	P	ØD
35001	-	-	-	-	-	-	-	-	-	-	-	-	-	-	-	-	-	-
35002	-	-	-	-	-	-	-	-	-	-	-	-	-	-	-	-	-	-
35003	414.5	36	140	414.5	36	160	434.5	56	200	434.5	56	200	444.5	66	250	444.5	66	250
35004	475.5			475.5			495.5			495.5			505.5			505.5		

CHPL	IEC 132			IEC 160			IEC 180			IEC 200			IEC 225			IEC 250		
	LP	P	ØD	LP	P	ØD	LP	P	ØD	LP	P	ØD	LP	P	ØD	LP	P	ØD
35001	-	-	-	370	150	-	370	150	-	370	150	400	359	139	450	359	139	550
35002	-	-	-	425	118	350	425	118	350	455	148	400	-	-	-	-	-	-
35003	478.5	100	300	517.5	139	350	517.5	139	350	-	-	-	-	-	-	-	-	-
35004	539.5			578.5			-	-	-	-	-	-	-	-	-	-	-	-

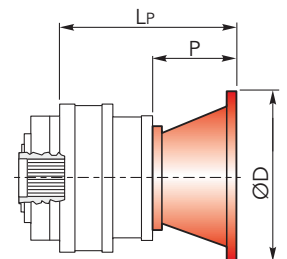

**CHPL 35000 CF - Alberi maschi entrata**

**CHPL 35000 CF - Male input shafts**

CHPL	CM42				CM65				CP65			
	LT	T	LE	ØE	LT	T	LE	ØE	LT	T	LE	ØE
35001	-	-	-	-	-	-	-	-	-	-	-	-
35002	-	-	-	-	428.5	121.5	105	65 h6	460	153	105	65 h6
35003	471.5	93	82	42 h6	513.5				545			
35004	532.5				-	-	-	-	-	-	-	-

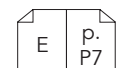
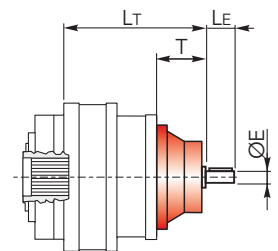



## DIMENSIONI CF

## CF DIMENSIONS

CHPL/CHPLB 35000

CHPL 35000 CF - Riduttore a vite senza fine CHM in entrata

CHPL 35000 CF - CHM input worm gearboxes

CHPL	CHM 50					CHM 63					CHM 75				
	Lv	I	H	M	N	Lv	I	H	M	N	Lv	I	H	M	N
35001	-					-					-				
35002	-					-					-				
35003	504	50	110	60	80	513.5	63	135	72	95	492.5	75	161	86	112.5
35004	565					574.5					553.5				

CHPL	CHM 90					CHM 110					CHM 130				
	Lv	I	H	M	N	Lv	I	H	M	N	Lv	I	H	M	N
35001	-					-					-				
35002	-					445					452				
35003	502.5	90	193	103	129.5	530	110	237.5	127.5	160	537	130	277.5	147.5	180
35004	563.5														

CHPL	CHM 150				
	Lv	I	H	M	N
35001	-				
35002	467				
35003	552	150	320	170	210
35004	-				

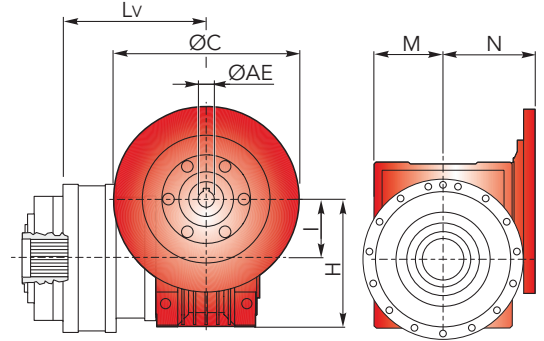

CHPLB 35000 CF - Flange motori IEC

CHPLB 35000 CF - IEC Motor flanges

CHPLB	IEC 63				IEC 71				IEC 80				IEC 90				IEC 100			
	L	Lp	P	ØD	L	Lp	P	ØD	L	Lp	P	ØD	L	Lp	P	ØD	L	Lp	P	ØD
35002	-				-				-				-				-			
35003	-				-				-				-				-			
35004	480	276	36	140	480	276	36	160	480	296	56	200	480	296	56	200	480	306	66	250

CHPLB	IEC 112				IEC 132				IEC 160				IEC 180				IEC 200			
	L	Lp	P	ØD	L	Lp	P	ØD	L	Lp	P	ØD	L	Lp	P	ØD	L	Lp	P	ØD
35002	-				-				285	433	118	350	285	433	118	350	285	463	148	400
35003	-				-				442				442							
35004	480	306	66	250	480	340	66	300	480	379	139									

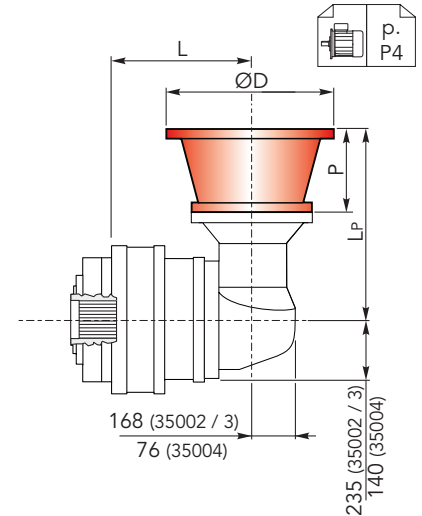

CHPLB 35000 CF - Alberi maschi entrata

CHPL 35000 CF - Male input shafts

CHPLB	CM42					CM65					CP65				
	L	Lt	T	Le	ØE	L	Lt	T	Le	ØE	L	Lt	T	Le	ØE
35002	-					285					285	468			
35003	-					442	436.5	121.5	105	65 h6	442		153	105	65 h6
35004	480	333	93	82	42 h6	480	377.5				480	409			

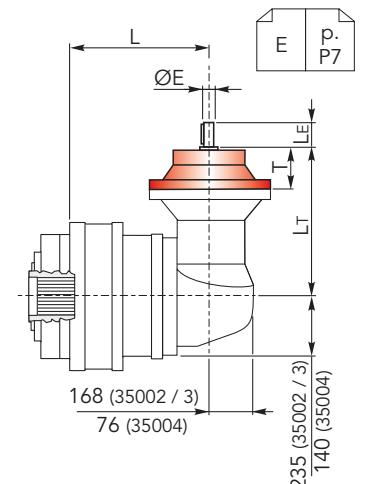



## DIMENSIONI CFS

## CFS DIMENSIONS

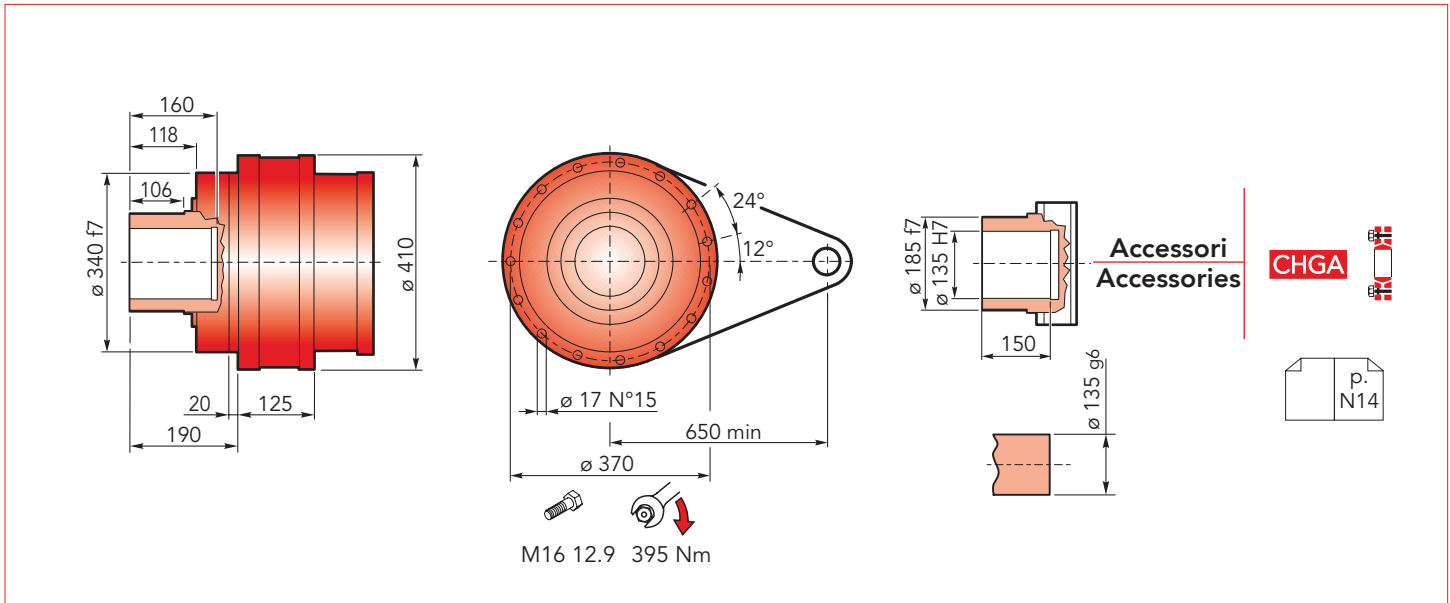

### CHPL 35000 CFS - Flange motori IEC

### CHPL 35000 CFS- IEC Motor flanges

CHPL	IEC 63			IEC 71			IEC 80			IEC 90			IEC 100			IEC 112		
	LP	P	ØD	LP	P	ØD	LP	P	ØD	LP	P	ØD	LP	P	ØD	LP	P	ØD
35001	-	-	-	-	-	-	-	-	-	-	-	-	-	-	-	-	-	-
35002	-	-	-	-	-	-	-	-	-	-	-	-	-	-	-	-	-	-
35003	414.5	36	140	414.5	36	160	434.5	56	200	434.5	56	200	444.5	66	250	444.5	66	250
35004	475.5	-	-	475.5	-	-	495.5	-	-	495.5	-	-	505.5	-	-	505.5	-	-

CHPL	IEC 132			IEC 160			IEC 180			IEC 200			IEC 225			IEC 250		
	LP	P	ØD	LP	P	ØD	LP	P	ØD	LP	P	ØD	LP	P	ØD	LP	P	ØD
35001	-	-	-	370	150	-	370	150	-	370	150	400	359	139	450	359	139	550
35002	-	-	-	425	118	350	425	118	350	455	148	400	-	-	-	-	-	-
35003	478.5	-	-	517.5	-	350	517.5	139	350	-	-	-	-	-	-	-	-	-
35004	539.5	100	300	578.5	139	350	-	-	-	-	-	-	-	-	-	-	-	-

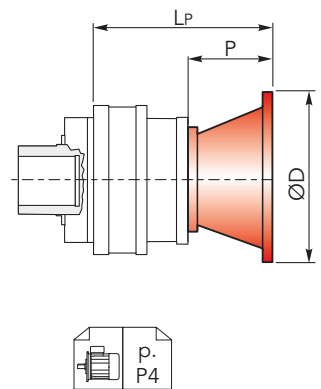

### CHPL 35000 CFS - Alberi maschi entrata

### CHPL 35000 CFS - Male input shafts

CHPL	CM42				CM65				CP65			
	LT	T	LE	ØE	LT	T	LE	ØE	LT	T	LE	ØE
35001	-	-	-	-	-	-	-	-	-	-	-	-
35002	-	-	-	-	428.5	-	-	-	460	-	-	-
35003	471.5	93	82	42 h6	513.5	121.5	105	65 h6	545	153	105	65 h6
35004	532.5	-	-	-	-	-	-	-	-	-	-	-

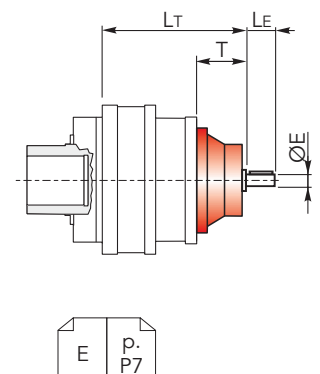



## DIMENSIONI CFS

## CFS DIMENSIONS

CHPL/CHPLB 35000

CHPL 35000 CFS - Riduttore a vite senza fine CHM in entrata CHPL 35000 CFS - CHM input worm gearboxes

CHPL	CHM 50					CHM 63					CHM 75				
	Lv	I	H	M	N	Lv	I	H	M	N	Lv	I	H	M	N
35001	-					-					-				
35002	-					-					-				
35003	504	50	110	60	80	513.5	63	135	72	95	492.5	75	161	86	112.5
35004	565					574.5					553.5				

CHPL	CHM 90					CHM 110					CHM 130				
	Lv	I	H	M	N	Lv	I	H	M	N	Lv	I	H	M	N
35001	-					-					-				
35002	-					445					452				
35003	502.5					530	110	237.5	127.5	160	537	130	277.5	147.5	180
35004	563.5	90	193	103	129.5										

CHPL	CHM 150				
	Lv	I	H	M	N
35001	-				
35002	467				
35003	552	150	320	170	210
35004	-				

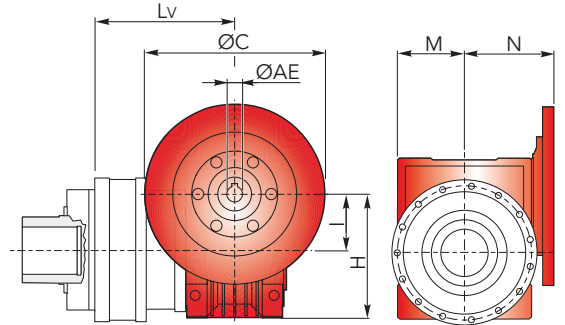

## CHPLB 35000 CFS - Flange motori IEC

## CHPLB 35000 CFS - IEC Motor flanges

CHPLB	IEC 63				IEC 71				IEC 80				IEC 90				IEC 100			
	L	Lp	P	ØD	L	Lp	P	ØD	L	Lp	P	ØD	L	Lp	P	ØD	L	Lp	P	ØD
35002	-				-				-				-				-			
35003	-				-				-				-				-			
35004	480	276	36	140	480	276	36	160	480	296	56	200	480	296	56	200	480	306	66	250

CHPLB	IEC 112				IEC 132				IEC 160				IEC 180				IEC 200			
	L	Lp	P	ØD	L	Lp	P	ØD	L	Lp	P	ØD	L	Lp	P	ØD	L	Lp	P	ØD
35002	-				-				285				285	433	118		285	463	148	400
35003	-				-				442			350	442	433	118	350	-			
35004	480	306	66	250	480	340	66	300	480	379	139		-				-			

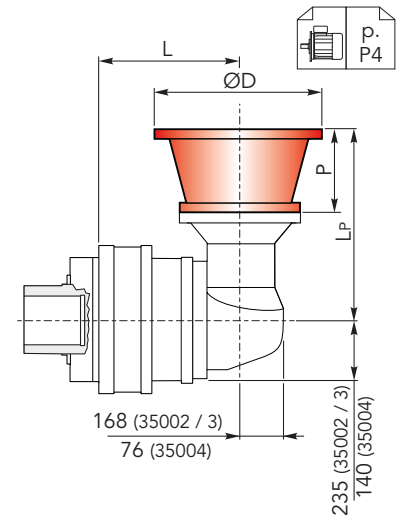

## CHPLB 35000 CFS - Alberi maschi entrata

## CHPL 35000 CFS - Male input shafts

CHPLB	CM42					CM65					CP65						
	L	Lt	T	Le	ØE	L	Lt	T	Le	ØE	L	Lt	T	Le	ØE		
35002	-					285					285						
35003	-					442	436.5		121.5	105	65 h6	442	468		153	105	65 h6
35004	480	333	93	82	42 h6	480	377.5				480	409					

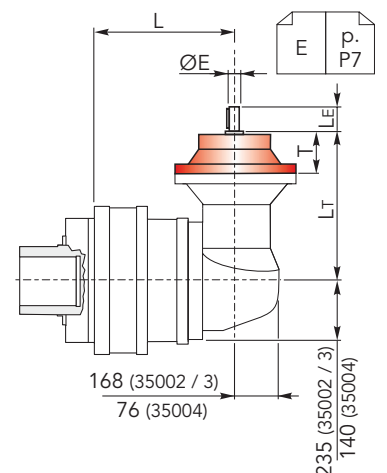



## DIMENSIONI CCPC

## CCPC DIMENSIONS

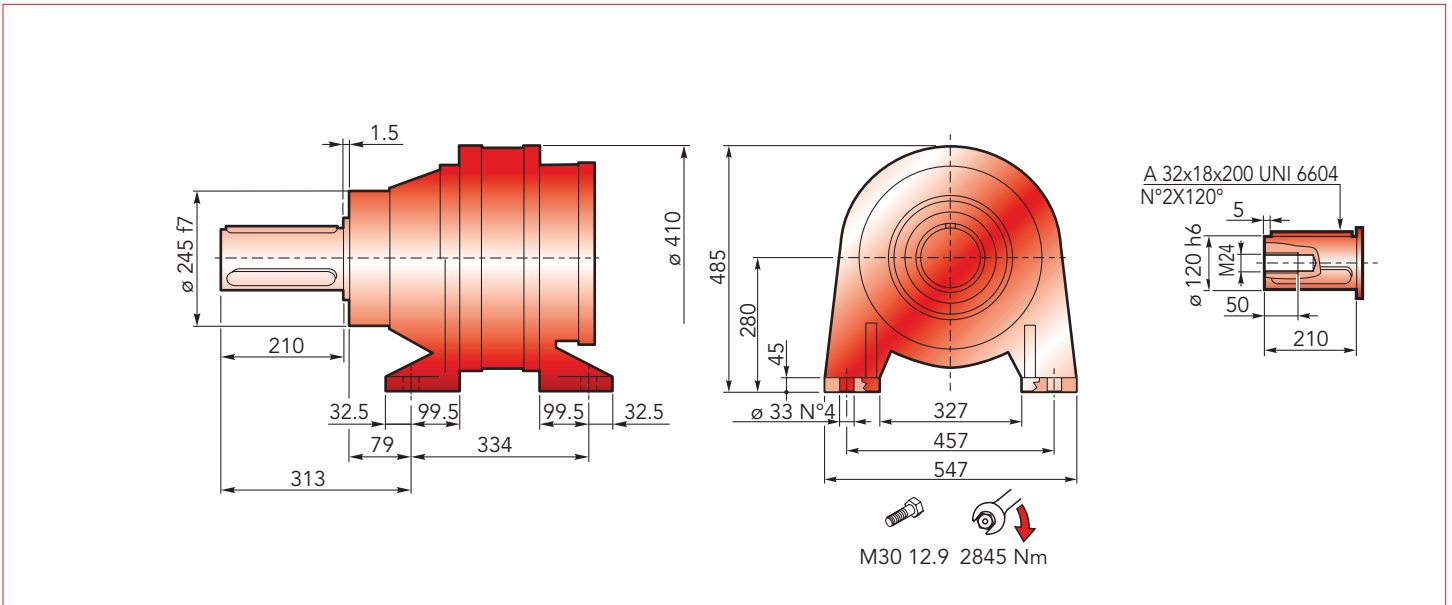

### CHPL 35000 CCPC - Flange motori IEC

### CHPL 35000 CCPC- IEC Motor flanges

CHPL	IEC 63			IEC 71			IEC 80			IEC 90			IEC 100			IEC 112		
	LP	P	ØD	LP	P	ØD	LP	P	ØD	LP	P	ØD	LP	P	ØD	LP	P	ØD
35001	-	-	-	-	-	-	-	-	-	-	-	-	-	-	-	-	-	-
35002	-	-	-	-	-	-	-	-	-	-	-	-	-	-	-	-	-	-
35003	627	-	140	627	36	160	647	56	200	647	56	200	657	66	250	657	66	250
35004	688	36	140	688	36	160	708	56	200	708	56	200	718	66	250	718	66	250

CHPL	IEC 132			IEC 160			IEC 180			IEC 200			IEC 225			IEC 250		
	LP	P	ØD	LP	P	ØD	LP	P	ØD	LP	P	ØD	LP	P	ØD	LP	P	ØD
35001	-	-	582.5	150	-	582.5	150	-	582.5	150	400	571.5	139	450	571.5	139	550	-
35002	-	-	637.5	118	350	637.5	118	350	667.5	148	400	-	-	-	-	-	-	-
35003	691	-	300	730	139	350	730	139	-	-	-	-	-	-	-	-	-	-
35004	752	100	300	791	139	350	-	-	-	-	-	-	-	-	-	-	-	-

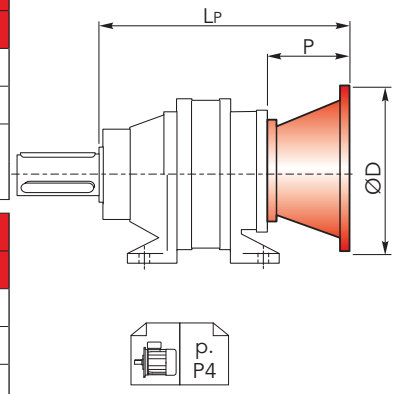

### CHPL 35000 CCPC - Alberi maschi entrata

### CHPL 35000 CCPC - Male input shafts

CHPL	CM42				CM65				CP65			
	LT	T	LE	ØE	LT	T	LE	ØE	LT	T	LE	ØE
35001	-	-	-	-	-	-	-	-	-	-	-	-
35002	-	-	-	-	641	121.5	105	65 h6	672.5	153	105	65 h6
35003	684	93	82	42 h6	726	121.5	105	65 h6	757.5	153	105	65 h6
35004	745	93	82	42 h6	-	-	-	-	-	-	-	-

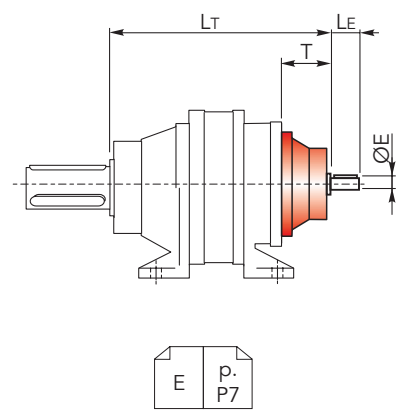



## DIMENSIONI CCPC

## CCPC DIMENSIONS

CHPL 35000 CCPC - Riduttore a vite senza fine CHM in entrata CHPL 35000 CCPC - CHM input worm gearboxes

CHPL	CHM 50					CHM 63					CHM 75				
	Lv	I	H	M	N	Lv	I	H	M	N	Lv	I	H	M	N
35001	-					-					-				
35002	-					-					-				
35003	716.5	50	110	60	80	726	63	135	72	95	705	75	161	86	112.5
35004	777.5					787					766				

CHPL	CHM 90					CHM 110					CHM 130					
	Lv	I	H	M	N	Lv	I	H	M	N	Lv	I	H	M	N	
35001	-					-					-					
35002	-					657.5	110	237.5	127.5	160	664.5	130	277.5	147.5	180	
35003	715	90	193	103	129.5	742.5					749.5					
35004	776															

CHPL	CHM 150				
	Lv	I	H	M	N
35001	-				
35002	679.5	150	320	170	210
35003	764.5				
35004	-				

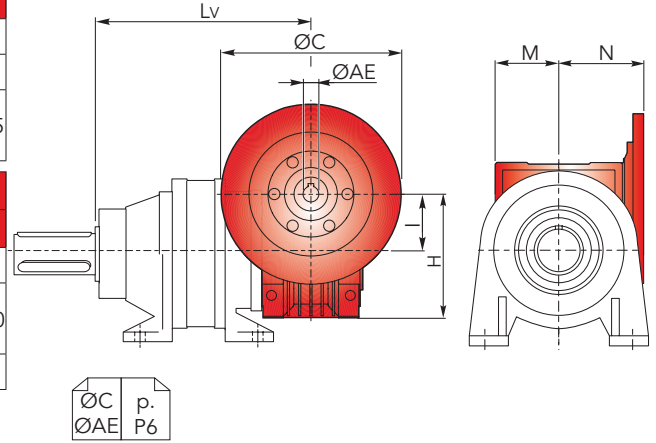

CHPLB 35000 CCPC - Flange motori IEC

CHPLB 35000 CCPC - IEC Motor flanges

CHPLB	IEC 63				IEC 71				IEC 80				IEC 90				IEC 100			
	L	Lp	P	ØD	L	Lp	P	ØD	L	Lp	P	ØD	L	Lp	P	ØD	L	Lp	P	ØD
35002	-				-				-				-				-			
35003	-				-				-				-				-			
35004	692.5	276	36	140	692.5	276	36	160	692.5	296	56	200	692.5	296	56	200	692.5	306	66	250

CHPLB	IEC 112				IEC 132				IEC 160				IEC 180				IEC 200						
	L	Lp	P	ØD	L	Lp	P	ØD	L	Lp	P	ØD	L	Lp	P	ØD	L	Lp	P	ØD			
35002	-				-				497.5	433	118	497.5	433	118	350	497.5	463	148	400	-			
35003	-				-				654.5			654.5				-				-			
35004	692.5	306	66	250	692.5	340	66	300	692.5	379	139				-				-				

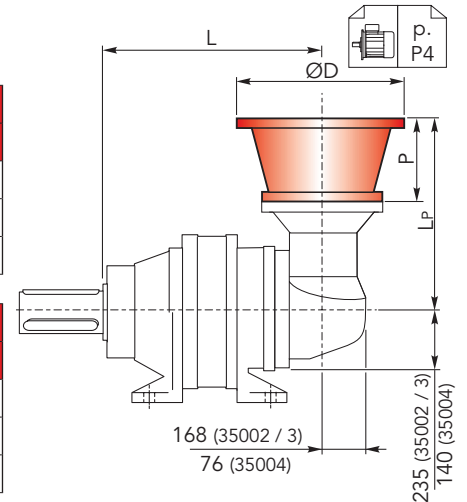

CHPLB 35000 CCPC - Alberi maschi entrata

CHPL 35000 CCPC - Male input shafts

CHPLB	CM42					CM65					CP65					
	L	Lt	T	Le	ØE	L	Lt	T	Le	ØE	L	Lt	T	Le	ØE	
35002	-					497.5	436.5				497.5	468				
35003	-					654.5		121.5	105	65 h6	654.5		153	105	65 h6	
35004	692.5	333	93	82	42 h6	692.5	377.5				692.5	409				

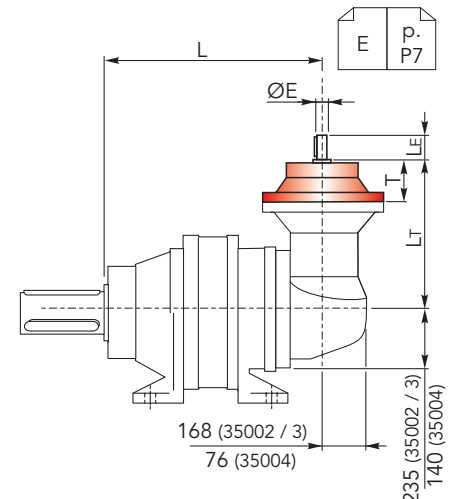



## ACCESSORI

## ACCESSORIES

CHFF

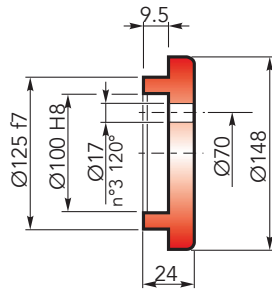

Fondello di arresto / Stop bottom plate

Codice / Code:  
1075.005.000

CHBS

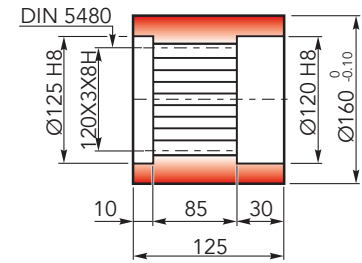

Boccola scanalata / Splined bushing

Codice / Code:  
9171.104.076

CHKB

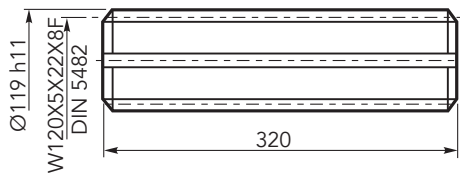

Barra scanalata / Splined rod

Codice / Code:  
3071.588.042

CHGA



Giunto di attrito / Shrink disc

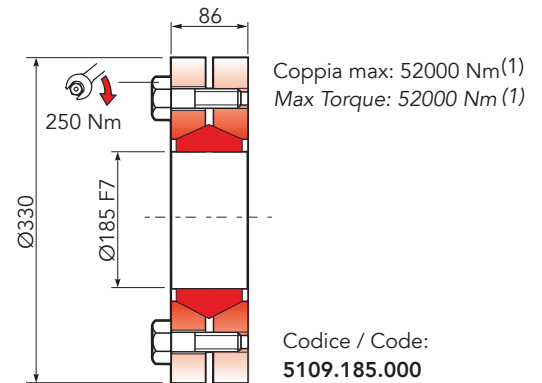

(1): Coppia max indicata è valida solo con calettatori forniti da Chiaravalli S.p.A.

(1): The maximum torque indicated is valid only with shrink discs supplied by Chiaravalli S.p.A.

CHFL

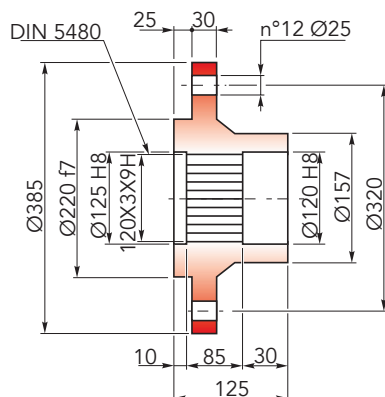

Flangia / Flange

Codice / Code:  
9171.103.098





## CARICHI RADIALI (Fr)

## RADIAL LOADS (Fr)

Nel diagramma seguente, sono indicati i carichi radiali  $F_r$  (N) applicabili sull'albero uscita in funzione della distanza di applicazione  $L$  rispetto alla battuta dell'albero.

The hereunder table shows the allowable radial loads  $F_r$  (N) on the output shaft with reference to the distance  $L$ .

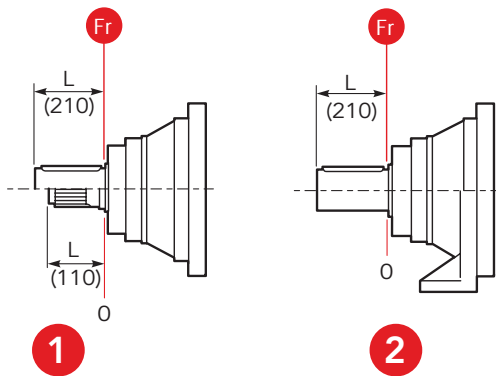
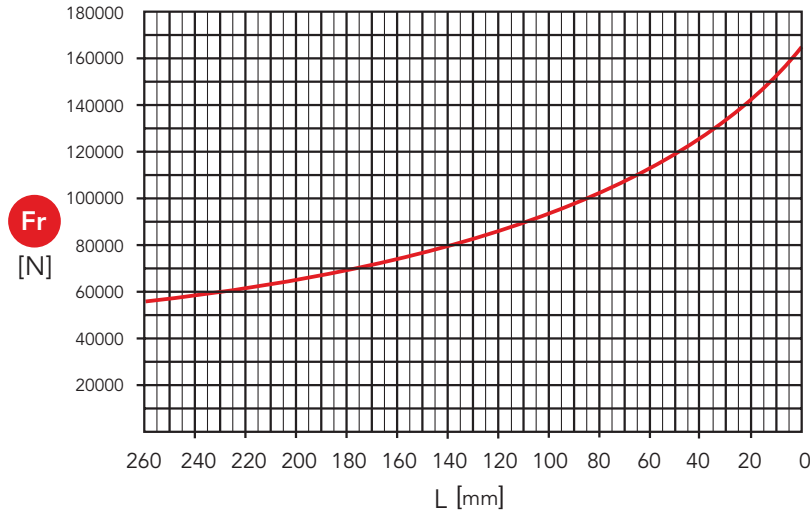

- 1 Uscita / Output: CMS, CMC
- 2 Uscita / Output: CCPC

## CARICHI ASSIALI (Fa)

## AXIAL LOADS (Fa)

Nella tabella seguente sono indicati i carichi assiali  $F_a$  (N) applicabili sull'albero di uscita in funzione della direzione di applicazione del carico e della versione.

The hereunder table shows the allowable axial loads  $F_a$  (N) on the output shaft with reference to the load direction and the output type.

	1	2	
$F_a$ [N]	80000	80000	←
	100000	100000	→

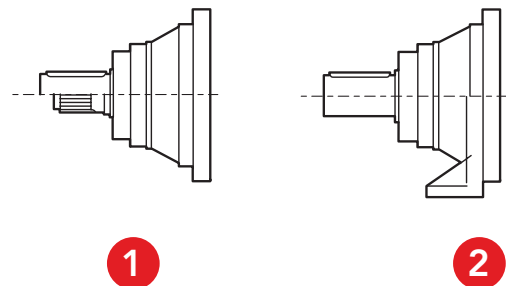

- 1 Uscita / Output: CMS, CMC
- 2 Uscita / Output: CCPC





## MOTORI ELETTRICI

## ELECTRIC MOTORS

CHIARAVALLI può fornire ai suoi clienti differenti motorizzazioni elettriche installabili sui riduttori epicicloidali lineari/angolari o sui combinati vite senza fine.

Tutti i nostri motori sono forniti con grado di protezione IP55, classe di isolamento F e separatore di fase per l'utilizzo sotto inverter, in questo caso possono essere forniti completi di servoventilazione.

### Principali caratteristiche

Le principali caratteristiche dei motori elettrici CHIARAVALLI sono:

- Motori con rotore a gabbia, chiusi con ventilazione superficiale esterna.
- Progetto, costruzione e collaudo in conformità alle norme CEI2-3, norme internazionali IEC 34-1 ed alle principali norme straniere.
- Potenze-dimensioni secondo le norme IEC 72, norme nazionali UNEL-MEC.
- Classe isolamento F.
- Protezione IP55.
- Servizio continuo S1.
- Direttiva Europea ROHS 2002/95/CE.
- Separatori di fase.
- A richiesta motori da 160 a 355.
- Volt 400/690 standard da 160 a 355 a richiesta sugli altri.

### Simbologia

n	[rpm]	Velocità di rotazione	Rotation speed
P <sub>n</sub>	[kW]	Potenza nominale	Nominal power
M <sub>n</sub>	[Nm]	Coppia nominale	Nominal torque
I <sub>n</sub>	[A]	Corrente nominale	Nominal current
I <sub>s</sub>	[A]	Corrente di spunto	Starting current
M <sub>s</sub>	[Nm]	Coppia di spunto	Starting torque
M <sub>max</sub>	[Nm]	Coppia massima	Max torque
V	[V]	Tensione	Voltage
V <sub>p</sub>	[V]	Tensione di targa	Plate voltage
F	[Hz]	Frequenza	Frequency
CosØ		Fattore di potenza	Power factor
C	[µF]	Capacità del condensatore	Capacitor
η	[%]	Rendimento	Efficiency
Fr	[N]	Carico radiale	Radial load

CHIARAVALLI Group S.p.A. can supply different electric motorizations to its customers which can be mounted on the planetary, linear/ angular gearboxes or on double worm gearboxes.

All our motors are supplied with level of protection IP55, insulation class F and phase separator to be used under frequency variator and in this case can be supplied complete with forced ventilation.

### Main characteristics

Main characteristic of CHIARAVALLI electric motors are:

- Motors with cage rotor, closed with external surface ventilation/ fan cooled ventilation
- Project, manufacturing and testing in accordance with CEI2-3 regulations, IEC 34-1 international regulation and with main foreign regulation.
- Power and dimensions in accordance with IEC 72 and national UNEL-MEC regulations.
- Insulation class F
- Protection IP55
- S1 continuous service
- ROHS 2002/95/CE European Directive
- Phase separators
- Motors from 160 to 355
- Voltage 400/690 standard on motors from 160 to 355 on demand for the others

### Symbols



## MOTORI ELETTRICI

## ELECTRIC MOTORS

### Funzionamento a 60 Hz

### Operation at 60 Hz

I motori CHIARAVALLI possono funzionare con frequenza a 60 Hz con differenze di prestazione e grandezze elettriche applicando i coefficienti moltiplicativi indicati nella tabella.

CHIARAVALLI motors can work at 60 Hz frequency with different performances and electrical size as described on the following chart.

Coefficienti di conversione per funzionamento da 50 Hz a 60 Hz / Conversion coefficient for function from 50 Hz to 60 Hz								
V <sub>p</sub> (50 Hz) [V]	V <sub>p</sub> (60 Hz) [V]	P <sub>n</sub> [kW]	I <sub>n</sub> [A]	M <sub>n</sub> [Nm]	n [rpm]	I <sub>s</sub> [A]	M <sub>s</sub> [Nm]	M <sub>max</sub> [Nm]
230 +/- 10%	220 +/- 5%	1	1	0.83	1.2	0.83	0.83	0.83
230 +/- 10%	230 +/- 10%	1	0.95	0.83	1.2	0.83	0.83	0.83
230 +/- 10%	254 +/- 5%	1.15	1.02	0.96	1.2	0.93	0.93	0.93
230 +/- 10%	277 +/- 5%	1.2	1	1	1.2	1	1	1
400 +/- 10%	380 +/- 5%	1	1	0.83	1.2	0.83	0.83	0.83
400 +/- 10%	400 +/- 10%	1	0.95	0.83	1.2	0.83	0.83	0.83
400 +/- 10%	440 +/- 5%	1.16	1.02	0.96	1.2	0.93	0.93	0.93
400 +/- 10%	460 +/- 10%	1.15	1	0.96	1.2	0.96	0.96	0.96
400 +/- 10%	480 +/- 5%	1.2	1	1	1.2	1	1	1

### Tensione di alimentazione

### Power voltage

I motori CHIARAVALLI sono progettati per essere utilizzati sulla rete Europea 230/400 Volt +/- 10% - 50 Hz e 400/690 +/- 10% - 50 Hz.

CHIARAVALLI motors are configured to be used all over the European net system 230/440 Volt +/-10% -50Hz and 400/690 +/-10%-50Hz

Questo significa che lo stesso motore può funzionare sulle seguenti reti ancora esistenti:

This means that the same motor can be used on the following existing network:

- 220/380 Volt +/- 5%
- 230/400 Volt +/- 10%
- 240/415 Volt +/- 5%
- 380/660 Volt +/- 5%
- 400/690 Volt +/- 10%
- 415/720 Volt +/- 5%

- 220/380 Volt +/- 5%
- 230/400 Volt +/- 10%
- 240/415 Volt +/- 5%
- 380/660 Volt +/- 5%
- 400/690 Volt +/- 10%
- 415/720 Volt +/- 5%

rispondendo ai requisiti richiesti dalle normative di numerosi paesi.

answering to the required standard conditions in many countries.





## MOTORI ELETTRICI

## ELECTRIC MOTORS

### Caratteristiche tecniche elettriche

### Electric technical characteristics

IE1		n° poli n° poles	P <sub>n</sub>	V	I <sub>n</sub>	M <sub>n</sub>	η	CosØ	
			[kW]	[V]	[A]	[Nm]	[%]		
CHT 56	B4	4	0.09	230/400	0.43	0.64	50.00	0.61	3.20
CHT 63	A4	4	0.12	230/400	0.47	0.85	57.00	0.64	3.90
CHT 63	B4	4	0.18	230/400	0.70	1.27	57.00	0.65	4.50
CHT 63	C4	4	0.22	230/400	0.92	1.77	59.00	0.67	4.80
CHT 71	A4	4	0.25	230/400	0.84	1.77	60.00	0.62	5.60
CHT 71	B4	4	0.37	230/400	1.12	2.58	65.00	0.74	6.20
CHT 71	C4	4	0.55	230/400	1.61	3.81	66.00	0.75	7.00
CHT 80	A4	4	0.55	230/400	1.59	3.81	67.00	0.75	8.90

IE2		n° poli n° poles	P <sub>n</sub>	V	I <sub>n</sub>	M <sub>n</sub>	η	CosØ	
			[kW]	[V]	[A]	[Nm]	[%]		
CHT 80	B4	4	0.75	230/400	1.79	5.04	79.60	0.76	11.20
CHT 80	C4	4	1.10	230/400	2.72	7.39	81.40	0.71	13.50
CHT 90	S4	4	1.10	230/400	2.50	7.37	81.40	0.78	13.90
CHT 90	L4	4	1.50	230/400	3.31	10.09	82.80	0.79	16.20
CHT 90	M4	4	2.20	230/400	5.09	14.71	84.30	0.74	20.50
CHT100	LA4	4	2.20	230/400	4.83	14.70	84.30	0.78	22.70
CHT100	LB4	4	3.00	230/400	6.33	20.00	85.50	0.80	26.50
CHT112	M4	4	4.00	230/400	8.23	26.60	86.60	0.81	32.50
CHT 112	L4	4	5.50	230/400	11.25	36.57	87.90	0.80	39.00
CHT 132	S4	4	5.50	230/400	11.00	36.22	87.90	0.83	44.00
CHT 132	M4	4	7.50	230/400	14.50	50.00	88.70	0.84	53.50
CHT 160	M4	4	11	400/690	21.3	71.9	88.5	0.84	118
CHT 160	L4	4	15	400/690	28.6	98.1	89.5	0.85	132
CHT 180	M4	4	18.5	400/690	34.6	121	90.2	0.86	164
CHT 180	L4	4	22	400/690	41	143	91.2	0.85	182
CHT 200	L4	4	30	400/690	55	195	91.7	0.86	244
CHT 225	S4	4	37	400/690	66.4	240	92.3	0.87	258
CHT 225	M4	4	45	400/690	80.4	291	92.7	0.87	290
CHT 250	M4	4	55	400/690	98	355	93.4	0.87	388



## MOTORI ELETTRICI

## ELECTRIC MOTORS

### Dimensioni

### Dimensions

#### B5

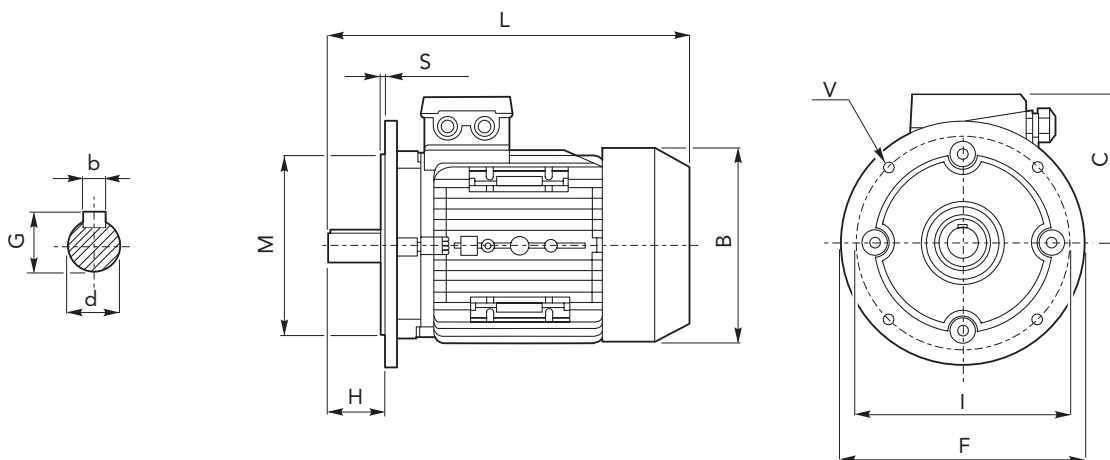

#### B14

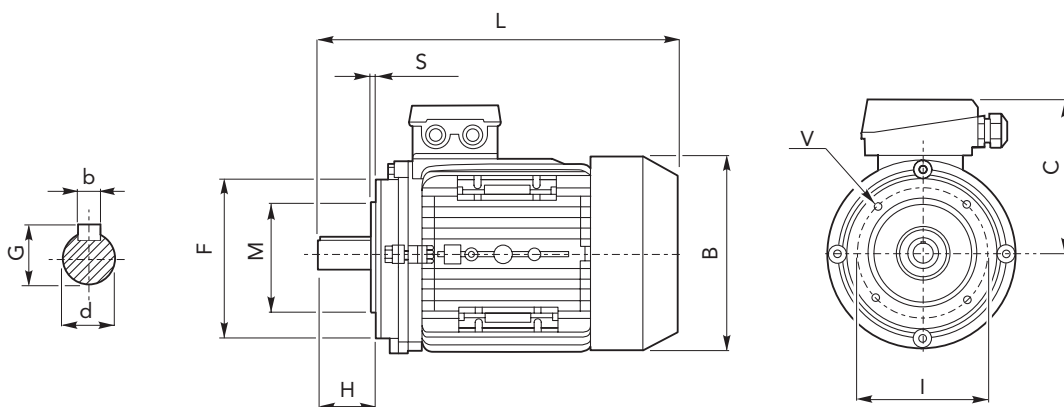

Tipo/Type	Dimensioni / Dimensions													
	d	H	b	G	B5					B14				
					I	M	F	V	S	I	M	F	V	S
CHT 56	9	20	3	10.2	100	80	120	7	3.0	65	50	80	M5	2.5
CHT 63	11	23	4	12.5	115	95	140	10	3.0	75	60	90	M5	2.5
CHT 71	14	30	5	16	130	110	160	10	3.5	85	70	105	M6	2.5
CHT 80	19	40	6	21.5	165	130	200	12	3.5	100	80	120	M6	3.0
CHT 90S	24	50	8	27	165	130	200	12	3.5	115	95	140	M8	3.0
CHT 90L/90M	24	50	8	27	165	130	200	12	3.5	115	95	140	M8	3.0
CHT 100 L	28	60	8	31	215	180	250	15	4.0	130	110	160	M8	3.5
CHT 112M	28	60	8	31	215	180	250	15	4.0	130	110	160	M8	3.5
CHT 132S	38	80	10	41	265	230	300	15	4.0	165	130	200	M10	4.0
CHT 132M	38	80	10	41	265	230	300	15	4.0	165	130	200	M10	4.0
CHT 160M	42	110	12	45	300	250	350	18	5	215	180	250	M12	4
CHT 160L	42	110	12	45	300	250	350	18	5	215	180	250	M12	4
CHT 180M	48	110	14	51.5	300	250	350	18	5	-	-	-	-	-
CHT 180L	48	110	14	51.5	300	250	350	18	5	-	-	-	-	-
CHT 200L	55	110	16	59	350	300	400	19	5	-	-	-	-	-
CHT 225S	60	140	18	64	400	350	450	19	5	-	-	-	-	-
CHT 225M	55	110	16	59	400	350	450	19	5	-	-	-	-	-
	60	140	18	64	400	350	450	19	5	-	-	-	-	-
CHT 250M	60	140	18	64	500	450	550	19	5	-	-	-	-	-
	65	140	18	69	500	450	550	19	5	-	-	-	-	-



## MOTORI ELETTRICI

## ELECTRIC MOTORS

Servoventilazione motori

Forced ventilation motors

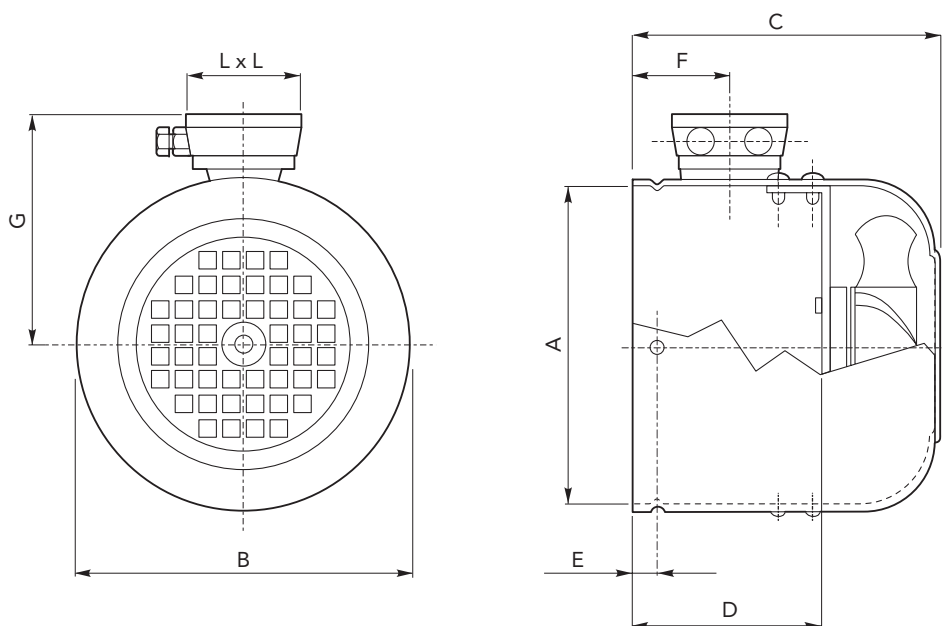

Ingombri monofasi con morsetteria IP55  
Dimension of single phase motors with IP55 terminal board.

A richiesta fornibili in trifase 400 Vac  
Forced ventilation kit three-phase models available on request.

Tipo/Type	Caratteristiche tecniche servoventilazione / Technical characteristics of Forced ventilation					
	V	F	n	P <sub>max</sub>	I <sub>max</sub>	Portata d'aria Air flow
	[V]	[Hz]	[rpm]	[kw]	[A]	[m <sup>3</sup> /h]
CHM GR. 63	230	50	2750	15	120	180
		60		14	100	
CHM GR. 71	230	50	2750	15	120	180
		60		14	100	
CHM GR. 80	230	50	2750	15	120	180
		60		14	100	
CMH GR. 90	230	50	2900	42	190	340
		60		36	180	
CHM GR. 100	230	50	2900	42	190	340
		60		36	180	
CHM GR. 112	230	50	2900	42	190	340
		60		36	180	
CHM GR. 132	230	50	2900	42	190	340
		60		36	180	



Per servoventilazione su taglie superiori alla 132, contattare il servizio tecnico CHIARAVALLI.  
For forced ventilation of sizes over 132 please contact our technical service CHIARAVALLI.



## PREDISPOSIZIONI PER RIDUTTORI A VITE SENZA FINE

## WORM GEAR CONNECTIONS

CHIARAVALLI può fornire ai suoi clienti riduttori epicicloidali combinati ai vite senza fine della serie CHM CHIARAVALLI. Per la selezione del riduttore a vite senza fine contattare il servizio tecnico CHIARAVALLI.

Il vite senza fine è installabile sulla versione lineare CHPL con il duplice scopo di:

- rendere l'ingresso ortogonale rispetto all'uscita dell'epicicloidale
- aumentare il rapporto di riduzione

Di seguito riportiamo le diverse predisposizioni attacco motore per i vite senza fine:

CHIARAVALLI can supply combined planetary gearboxes with worm gear of CHM CHIARAVALLI series to its customers. In order to choose the correct gearbox with worm gear connections, please contact CHIARAVALLI technical service.

The worm gearbox connection can be installed on the linear version CHPL with the double aim of:

- Have an orthogonal input and an planetary output
- Increase the ratio

Here following the different input motor adaptor for worm gear connections:

IEC su riduttori a vite senza fine CHM / IEC flnges on CHM worm gearboxes													
Taglia VSF VSF size	i											ØC	ØAE
	7.5	10	15	20	25	30	40	50	60	80	100		
IEC disponibili su vite senza fine / IEC wormgear available													
CHM 050	80	80	80	80	80	80	80	-	-	-	-	B5 200 B14 124	19
	71	71	71	71	71	71	71	71	71	71	71	B5 160 B14 105	14
	-	-	-	-	-	-	63	63	63	63	63	B5 140	11
CHM 063	90	90	90	90	90	90	-	-	-	-	-	B5 200 B14 140	24
	80	80	80	80	80	80	80	80	80	80	-	B5 200 B14 120	19
	-	-	-	-	-	-	71	71	71	71	71	B5 160 B14 105	14
CHM 075	100	100	100	-	-	-	-	-	-	-	-	B5 250 B14 160	28
	112	112	112	-	-	-	-	-	-	-	-	B5 200 B14 140	24
	90	90	90	90	90	90	90	90	-	-	-	B5 200 B14 120	19
	-	-	-	80	80	80	80	80	80	80	80	B5 160 B14 105	14
CHM 090	100	100	100	100	100	100	-	-	-	-	-	B5 250 B14 160	28
	112	112	112	112	112	112	-	-	-	-	-	B5 200 B14 140	24
	90	90	90	90	90	90	90	90	90	-	-	B5 200 B14 120	19
CHM 110	132	132	132	132	-	-	-	-	-	-	-	B5 300 B14 200	38
	100	100	100	100	100	100	100	100	100	100	-	B5 250 B14 160	28
	112	112	112	112	112	112	112	112	112	112	-	B5 200	24
CHM 130	132	132	132	132	132	132	132	-	-	-	-	B5 300 B14 200	38
	-	-	-	-	-	100	100	100	100	100	100	B5 250 B14 160	28
	112	112	112	112	112	112	112	112	112	112	112	B5 200	24
CHM 150	160	160	160	160	160	-	-	-	-	-	-	B5 350	42
	-	-	-	-	-	132	132	132	132	-	-	B5 300	38
	-	-	-	-	-	-	-	-	-	100	100	B5 250	28
										112	112		

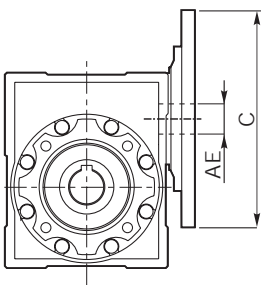





## ALBERI MASCHIO IN ENTRATA

## MALE INPUT SHAFTS

CHIARAVALLI può fornire ai suoi clienti diverse tipologie di alberi maschio in entrata.

CHIARAVALLI can supply different kind of male input shaft to its customers.

### Dimensioni / Dimensions

### Carichi radiali / Radial loads

#### CM42

**Kg** 9.0

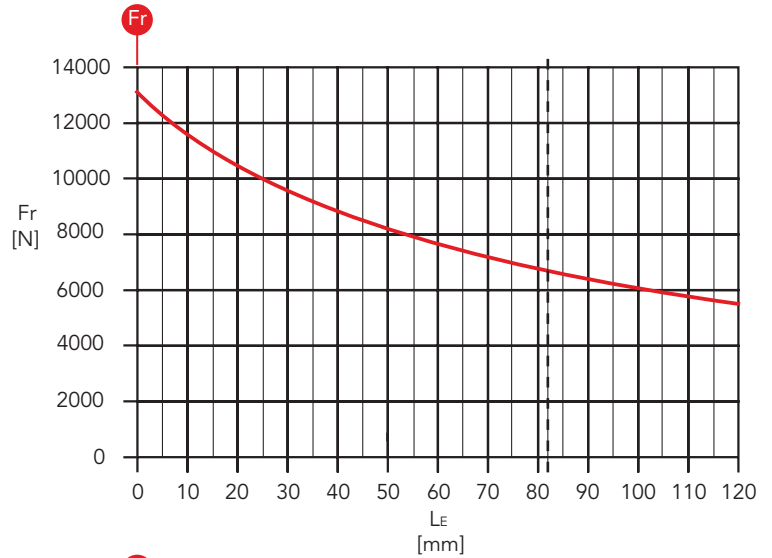
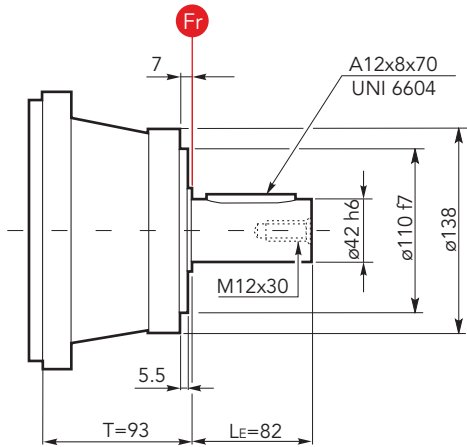

#### CM65

**Kg** 17.0

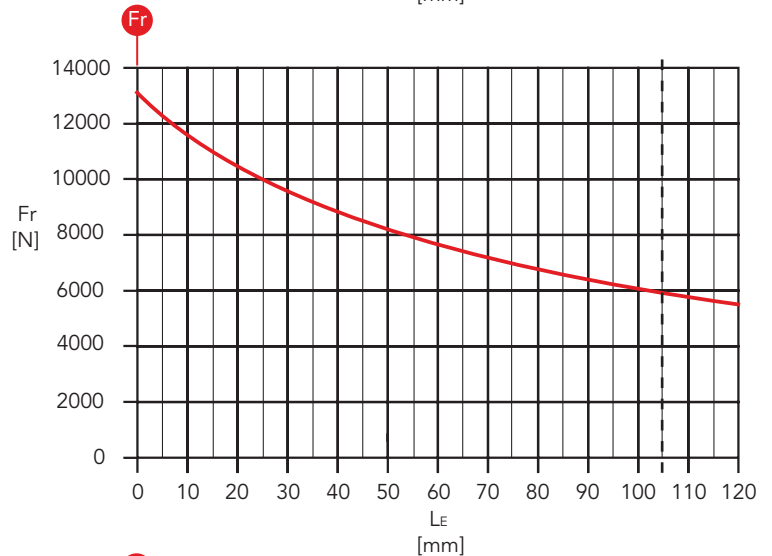
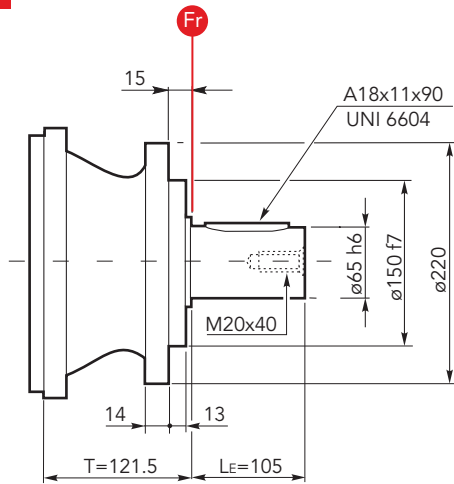

#### CP65

**Kg** 26.0

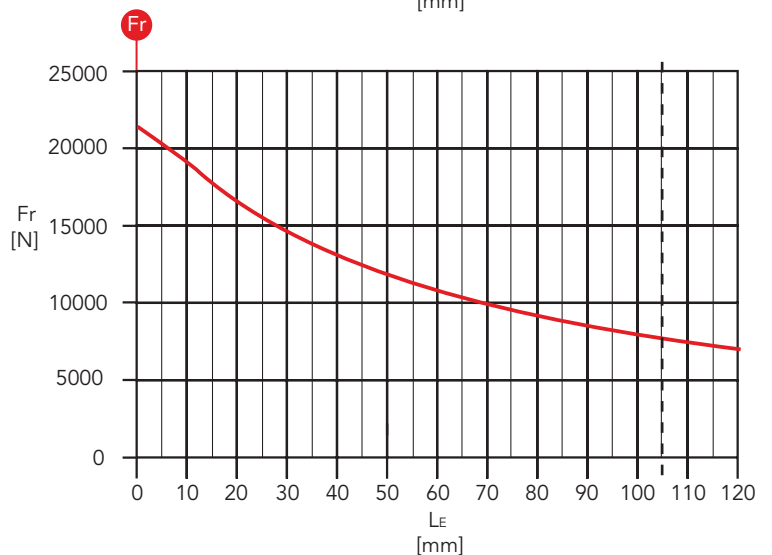
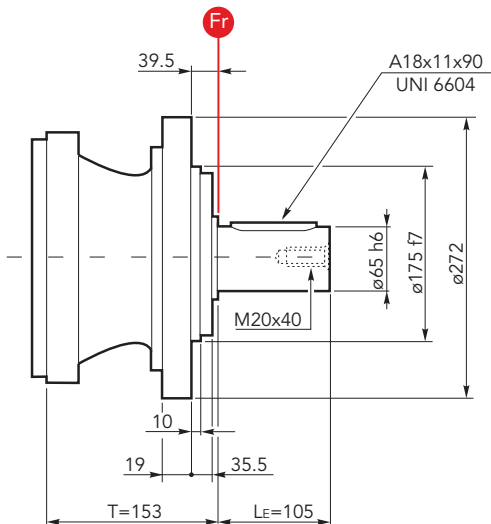



## PREDISPOSIZIONI PER MOTORI IDRAULICI

## HYDRAULIC MOTORS CONNECTION

CHIARAVALLI può offrire ai suoi clienti le predisposizioni per i più diffusi motori idraulici. Di seguito riportiamo gli ingressi disponibili.

Per ogni altra necessità non in tabella contattare il Servizio Tecnico CHIARAVALLI.

CHIARAVALLI can offer input motor adaptor for the most hydraulic motor. Following the available input adaptor. For any other requirement not listed in the chart here following, please contact technical service CHIARAVALLI.

	Tipo motore / Motor type	Codice / Code
DINAMIC OIL	AH100/BH150/BH175/BH200 28x34 UNI 8953	2074.013.024
	PH800 46x50 UNI 8953	2074.053.020
	PH250/PH300 32x38 UNI 8953	2074.053.016
	CH250/DH300/DH 350 32x38 UNI 8953	2074.053.003
	PH800/PH1250/MH1000 46x50 UNI 8953	2074.073.001
	PH800/PH1250/MH1000 46x50 UNI 8953	2074.083.001
EATON (CHAR-LYNN) SERIE 2000	A-H-S ø 25	2074.012.012
	A-H-S ø 25.4	2074.012.014
	A-H-S SAE 1"6B	2074.013.013
EATON (CHAR-LYNN) SERIE 4000	BEARINGLESS	2074.013.033
	ø 31.75 CH7.96	2074.012.017
	ø 32 CH10	2074.012.019
	12/24 DP TH14	2074.013.038
EATON (CHAR-LYNN) SERIE 4000	BEARINGLESS	2074.013.045
	ø 40 CH12	2074.012.027
	ø 31.75 CH7.96	2074.012.020
EATON (CHAR-LYNN) SERIE 6000	12/24 DP TH17	2074.013.016
	12/24 DP TH14	2074.013.038
EATON	MF-MV25 16/32 DP TH13	2074.013.001
	MF-MV25 16/32 DP TH15	2074.013.003
	MF-MV25 0 22.22 CH6.25	2074.012.001
	MF-MV (33/39/46) 16/32 DP TH21	2074.013.017
	MF-MV54 16/32 DP TH23	2074.013.018
	MF-MV (33/39/46/54) 12/24 DP TH14	2074.013.015
EATON (VICHERS)	25M 16/32 DP TH13	2074.013.001
	MVE-MFE19 16/32 DP TH15	2074.013.003
	35M-45M 12/24 DP TH14	2074.013.015
	35M-45M 0 31.75	2074.012.020
HAGGLUNDS ABEX DENISON	M1C/M4C/M4SC 16/32 DP TH13	2074.013.001
	M3B/M3B1/TM3B 16/32 DP TH9	2074.013.010
	M4C/M4SC 0 22.22 CH4/75	2074.012.003
	M3D/M1D/M4E/12/24 DP TH14	2074.013.015

	Tipo motore / Motor type	Codice / Code
INTERMOT	NHM 100/150 26x32 UNI 8953	2074.013.052
	NHM 700/800/900/1000/1100 46x50 UNI 8953	2074.053.020
	NHM 200/250/300 32x38 UNI 8953	2074.053.016
	NHM 400/450/500/600 36x42 UNI 8953	2074.053.017
	NHM 700/800/900/1000/1100 46x50 UNI 8953	2074.073.002
	NHM 700/800/900/1000/1100 46x50 UNI 8953	2074.083.002
	NHM 1400/1600/1800/2000 62x72 UNI 8953	2074.073.003
	NHM 1400/1600/1800/2000 62x72 UNI 8953	2074.083.003
	NHM 1400/1600/1800/2000 62x72 UNI 8953	2074.053.021
	NHM 1400/1600/1800/2000 62x72 UNI 8953	2074.053.021
LINDE	MF43M 16/32 DP TH15	2074.013.003
	MF63M 12/24 DP TH14	2074.013.015
	BMF35 25x22 DIN 5482 TH14	2074.013.070
	BMF50 30x27 DIN 5482 TH16	2074.013.060
	BMF 105 40x36 DIN 5482 TH20	2074.013.068
	BMF75 35x31 DIN 5482 TH18	2074.013.061
PARKER (VOLVO)	F11/10 (C-T) W20x1.25 DIN 5480 TH14	2074.013.046
	F11/19 (M-C-D) W25x1.25 DIN 5480 TH18	2074.013.068
	F12/40 (M-F-D) W32x2 DIN 5480 TH14	2074.013.020
	V11 (60/80) (M-S-S) 12/24 DP TH14	2074.013.015
	V12/60 (M-I-C) W30x2 DIN 5480 TH14	2074.013.019
	V12/60 (M-I-D) W35x2 DIN 5480 TH16	2074.013.021
	F11/10 (M-C-K) 0 20 CH6	2074.012.065
	F12/30 (M-F-Z) W25x1.25 DIN 5480 TH18	2074.013.062
	F11/39/58 (M-C-D) W30x2 DIN 5480 TH14	2074.013.030
	F12/80 (M-I-D) W40x2 DIN 5480 TH18	2074.013.064
	F11/78 (M-C-D) W40x2 DIN 5480 TH18	2074.013.065
	F11/110 (M-C-D) W40x2 DIN 5480 TH18	2074.013.034
	F11/110 (M-C-D) W40x2 DIN 5480 TH18	2074.053.018
V12-110 (U-S) S8/16 DP TH13	2074.053.005	
V12/110 (M-I-D) W45x2 DIN 5480 TH21	2074.053.006	
PARKER (TRW TORQMOTOR)	MF/MAC/MAF/MAB 0 25 CH8	2074.012.012
	MF/MAC/MAF/MAB 0 25.4 CH6.35	2074.013.014
	MF/MAC/MAF/MAB SAE 1"6B	2074.013.013
	MAB/MAE 0 31.75 CH7.96	2074.012.016
	ME 12/24 DP TH14	2074.013.047

Per una corretta scelta della predisposizione per motore idraulico contattare il Servizio Tecnico CHIARAVALLI.

For a correct choice of the input hydraulic motor adaptor, please contact CHIARAVALLI technical service.



## PREDISPOSIZIONI PER MOTORI IDRAULICI

## HYDRAULIC MOTORS CONNECTION

	Tipo motore / Motor type	Codice / Code
REXROTH BOSCH GROUP (HYDROMATIK)	A2FM (10/12/16) W25x1.25 DIN 5480 TH18	2074.013.009
	A2FM (23/28/32) W25x1.25 DIN 5480 TH18	2074.013.062
	A2FM (23/28/32) W30x2 DIN 5480 TH14	2074.013.063
	A2FM (45/56) W30x2 DIN 5480 TH14	2074.013.019
	A2FM 45 W32x2 DIN 5480 TH14	2074.013.020
	A2FM (56/83) W35x2 DIN 5480 TH16	2074.013.021
	A2FM 80 W35x2 DIN 5480 TH16	2074.013.071
	A2FM (80/90) W40x2 DIN 5480 TH18	2074.013.064
	A2FM 107 W40x2 DIN 5480 TH18	2074.013.065
	A2FM 107 W40x2 DIN 5480 TH18	2074.053.007
	A2FM (107/125) W45x2 DIN 5480 TH21	2074.053.006
	A2FM 160 W45x2 DIN 5480 TH21	2074.053.009
	A2FM (160/180) W50x2 DIN 5480 TH24	2074.053.008
	A6VM55 W35x2 DIN 5480 TH16	2074.013.021
	A6VM55 W30x2 DIN 5480 TH14	2074.013.019
	A6VM80 W35x2 DIN 5480 TH16	2074.013.071
	A6VM80 W40x2 DIN 5480 TH18	2074.013.064
	A6VM107 W40x2 DIN 5480 TH18	2074.013.065
	A6VM107 W40x2 DIN 5480 TH18	2074.053.007
	A6VM107 W45x2 DIN 5480 TH21	2074.053.006
A6VM160 W45x2 DIN 5480 TH21	2074.053.009	
SAI	SAI M05 28x34 UNI 8953	2074.013.041
	SAI M05 35x2 DIN 5480 TH16	2074.013.044
	SAI M1 28x34 UNI 8953	2074.013.022
	SAI M1 35x2 DIN 5480 TH16	2074.013.040
	SAI M2 36x40 UNI 8953	2074.013.066
	SAI M2/M3 36x40 UNI 8953	2074.053.010
	SAI M4 56x65 UNI 8953	2074.053.025
SAE J744C	SAE A 16/32 DP TH9	2074.013.010
	SAE B 16/32 DP TH13	2074.013.001
	SAE BB 16/32 DP TH15	2074.013.003
	SAE C 12/24 DP TH14	2074.013.015
	SAE CC 12/24 DP TH17	2074.013.016
	SAE D 8/16 DP TH13	2074.053.005
STAFFA	HMC 030	2074.052.001

	Tipo motore / Motor type	Codice / Code	
SAMHYDRAULIC	AG/AR 0 25 CH8	2074.012.012	
	AG/AR 0 25.4 CH6.35	2074.012.014	
	AG/AR 0 25x22 DIN 5482 TH14	2074.013.011	
	AG/AR SAE 1"6B	2074.013.013	
	AGS/ARS 0 25 CH8	2074.012.026	
	AGS/ARS 0 32 CH10	2074.012.019	
	AGS/ARS SAE 1"6B	2074.013.012	
	HPR 0 32 CH10	2074.012.019	
	HPRC	2074.013.006	
	SAUER-DANFOSS (SAUER-SUNSTRAND)	90M032/042 16/32 DP TH13	2074.013.001
		90M032/042 16/32 DP TH15	2074.013.003
		90M055 16/32 DP TH21	2074.013.017
90M075/100 16/32 DP TH23		2074.013.018	
90M130 16/32 DP TH27		2074.053.012	
MMF025 16/32 DP TH13		2074.013.001	
MMF035/MMV035 16/32 DP TH15		2074.013.003	
MMF046/MMV046 16/32 DP TH13		2074.013.001	
MMF046/MMV046 16/32 DP TH15		2074.013.003	
51V060 (C6) 13/32 DP TH21		2074.013.017	
SAUER-DANFOSS (SAUER-SUNSTRAND)	51V060 (S1) 12/24 DP TH14	2074.013.015	
	51V080 (C7) 16/32 DP TH23	2074.013.018	
	51V080 (S1) 12/24 DP TH14	2074.013.015	
	51V110 (C8) 16/32 DP TH27	2074.053.012	
	51V110 (F1) 8/16 DP TH13	2074.053.005	
	OMF/SMF18 16/32 DP TH13	2074.013.001	
	OMV/SMV 16/32 DP TH13	2074.013.067	
	SMF2 (033/052/070) 16/32 DP TH21	2074.013.017	
	SMF3 (049/066) 16/32 DP TH21	2074.013.017	
	WHITE	HS-RS 0 25	2074.012.012
HS-RS 0 1"6B		2074.013.013	
RE 0 32		2074.012.019	
RE 0 31.75		2074.012.016	

Per una corretta scelta della predisposizione per motore idraulico contattare il Servizio Tecnico CHIARAVALLI.

For a correct choice of the input hydraulic motor adaptor, please contact CHIARAVALLI technical service.



## FRENI IDRAULICI

## HYDRAULIC BRAKES

I riduttori epicicloidali CHIARAVALLI possono essere dotati di freni idraulici.

Tali freni vengono adottati come **freni di stazionamento del riduttore e quindi idonei ad assolvere alla sola frenatura statica.**

I freni hanno lubrificazione separata da quella del riduttore epicicloidale; prima della messa in servizio è quindi necessario provvedere al loro riempimento con idoneo olio idraulico.

Di seguito vengono riportate le caratteristiche principali dei freni idraulici disponibili:

*CHIARAVALLI planetary gearboxes can be equipped with hydraulic brakes.*

*These brakes are used as **parking brakes for the gearbox, act to discharge a statics braking only.***

*Brakes have separate lubrication from the planetary gearbox; before the start up, brakes need to be fulfilled by hydraulic oil.*

*Main characteristic for available hydraulic brakes are following:*

$T_{br}$  = Coppia frenante



$P_{brMin}$  = Pressione minima di esercizio

$P_{brMax}$  = Pressione massima di esercizio

$T_{br}$  = Braking torque

$P_{brMin}$  = Minimum operating pressure

$P_{brMax}$  = Maximum operating pressure

$T_{br}$ [Nm]	Applicabilità Applicability	$P_{brMin}$ [bar]	$P_{brMax}$ [bar]	 [l]		 Kg	Codice / Code
				Pos. di montaggio / Mount. position			
				V	B		
90		17	300	0.4	0.2	14	6074.000.500
140		23	300	0.4	0.2	14	6074.001.500
220		19	300	0.4	0.2	14	6074.002.500
250		22	300	0.6	0.3	21	5074.300.500
330		23	300	0.4	0.2	14	6074.003.500
400		35	300	0.6	0.3	21	5074.301.500
430		33	300	0.4	0.2	14	6074.004.500
550		39	300	0.4	0.2	14	6074.006.500
650		50	300	0.6	0.3	21	5074.302.500
800		38	300	0.6	0.3	21	5074.303.500
1000		45	300	0.6	0.3	21	5074.304.500
1250		45	300	0.6	0.3	21	5074.305.500
1500		45	300	0.6	0.3	21	5074.306.500
1700		50	300	0.6	0.3	21	5074.307.500

Applicabilità / Applicability				
Taglia / Size	CHPL		CHPLB	
	stadi / stage		stadi / stage	
1000	1-2-3-4	-	2-3-4	-
1600	1-2-3-4	-	2-3-4	-
2500	1-2-3-4	1	2-3-4	-
5000	1-2-3-4	1	2-3-4	-
7000	2-3-4	1-2	2-3-4	-
10000	2-3-4	1-2	2-3-4	-
16000	2-3-4	1-2	2-3-4	-
18000	3-4	2-3	3-4	2
25000	3-4	2-3	3-4	2
30000	3-4	2-3	3-4	-
35000	3-4	2-3	3-4	2-3

Per una corretta scelta del freno idraulico contattare il Servizio Tecnico CHIARAVALLI.

*For a correct choice of hydraulic brake, please contact CHIARAVALLI technical service.*



## CONDIZIONI GENERALI DI VENDITA

## GENERAL SALES CONDITIONS

**1) ORDINI** - Gli ordini per materiale standard e speciale devono essere sempre riferiti alle offerte della CHIARAVALLI GROUP SpA. Le ordinazioni sono impegnative per il cliente. Una volta iniziata la lavorazione non si accettano annullamenti o riduzioni dell'ordine salvo il risarcimento da parte del cliente dei costi di materiale e di lavorazione sostenuti fino al momento della sospensione. La quantità spedita può variare del  $\pm 5\%$  rispetto alla quantità ordinata.

**2) PREZZI** - Si intendono quelli in vigore alla data dell'ordine. Tutti i prezzi sono per merce resa franco Premezzo, imballo escluso. Qualora nel corso della fornitura si verificassero aumenti nel materiale o negli altri costi di produzione è facoltà della CHIARAVALLI GROUP SpA di adeguare i prezzi, anche per gli ordini in corso, agli aumenti verificatisi.

**3) TERMINI DI CONSEGNA** - Sono da considerarsi validi solo i termini di consegna indicati dalla CHIARAVALLI GROUP SpA. Essi sono da considerarsi comunque solo indicativi. Nei casi di difficoltà nell'approvvigionamento dei materiali, di sciopero o comunque in tutti i casi di forza maggiore, i termini di consegna vengono automaticamente prorogati senza che la CHIARAVALLI GROUP SpA sia tenuta a corrispondere indennizzi di sorta. Il cliente ha in ogni caso l'obbligo del ritiro del materiale speciale ordinato all'approntamento.

**4) SPEDIZIONI** - Le spedizioni si intendono a carico del committente ed eseguite a suo rischio e pericolo. I reclami per gli eventuali ammanchi devono presentarsi entro 8 gg. dal ricevimento della merce. Qualora venga pattuito che il costo del trasporto sia a carico, anche solo in parte, della CHIARAVALLI GROUP SpA, questa si riserva il diritto di scegliere il mezzo di spedizione più economico.

**5) IMBALLO** - L'imballo è fatturato al prezzo di costo.

**6) RESI** - Non si accettano ritorni di merce per qualsiasi causa se non preventivamente autorizzati e con imballi, eventuale sdoganamento e resa a totale carico dell'acquirente. A copertura degli oneri di magazzino ed amministrativi sarà emessa nota di addebito in ragione del 15% del valore della merce resa.

**7) GARANZIA** - La ditta CHIARAVALLI GROUP SpA si impegna a riparare o sostituire gratuitamente quei pezzi da essa riconosciuti difettosi. La merce contestata dev'essere resa alla sede della CHIARAVALLI GROUP SpA, franco di ogni spesa. La garanzia decade qualora i pezzi resi come difettosi siano stati riparati o manomessi. Le riparazioni di pezzi difettosi eseguite dal committente saranno riconosciute solamente dietro autorizzazione dalla CHIARAVALLI GROUP SpA e dopo approvazione di essa del preventivo di spesa. La CHIARAVALLI GROUP SpA non assume responsabilità nè riconosce indennizzi di sorta per danni che

**1) ORDERS** - Orders for special and standard material must always refer to offers made by CHIARAVALLI GROUP SpA. The orders are binding for the client. Once work has commenced no cancellations or order reductions will be accepted unless the client reimburses the costs of the material and the work carried out up to the moment in which the order was suspended. The quantity despatched can vary by  $\pm 5\%$  compared to the quantity ordered.

**2) PRICES** - The prices are those in force at the date of order. All prices are for goods delivered ex-works Premezzo, packing excluded. If there should be any increase in production and material costs over the duration of the supply, CHIARAVALLI GROUP SpA reserves the right to adapt the prices accordingly, even for orders in course.

**3) TERMS OF DELIVERY** - Only the terms of delivery indicated by CHIARAVALLI GROUP SpA are to be considered valid. However, they must only be considered as indicative. In the event of difficulty in the procurement of materials, strikes or in any event in all cases of force majeure, the terms of delivery will be automatically extended without CHIARAVALLI GROUP SpA having to pay any reimbursement for damages. The client is obligated to collect special material ordered when ready.

**4) DELIVERIES** - Deliveries are the responsibility of the purchaser and are carried out at his own risk and peril. Any claims for shortages must be presented within 8 days of receipt of the goods. If it is agreed that the cost of transport is to be paid, even if only in part, by CHIARAVALLI GROUP SpA, the latter reserves the right to choose the most economical means of transport.

**5) PACKING** - Packing will be invoiced at cost.

**6) RETURNS** - No returns for any reason will be accepted unless previously authorised and with packing, any customs clearance and the return paid for by the purchaser. To cover warehouse and administrative expenses a debit note will be issued for approx. 15% of the value of the goods returned.

**7) WARRANTY** - CHIARAVALLI GROUP SpA promises to repair or substitute free of charge any parts that they recognise as being defective. The questioned goods must be returned to the factory of CHIARAVALLI GROUP SpA, free of all expenses. The warranty will be considered cancelled in the event that the parts returned as defective have been repaired or tampered with. The repair of defective parts carried out by the purchaser will only be accepted after authorisation from CHIARAVALLI GROUP SpA and after their approval of the cost estimate. CHIARAVALLI GROUP SpA does not accept responsibility or pay any reimbursement



si verificassero durante l'impiego dei suoi prodotti anche se difettosi. Non viene riconosciuta la garanzia per perdita di lubrificante determinata da usura degli anelli di tenuta.

**8) RESPONSABILITÀ** - La ditta CHIARAVALLI GROUP SpA non assume responsabilità nè riconosce indennizzi di sorta per danni che si verificassero durante l'impiego dei suoi prodotti anche se difettosi. La CHIARAVALLI GROUP SpA declina ogni responsabilità nell'esecuzione di particolari su disegno del cliente sottostanti ad eventuali brevetti.

**9) PAGAMENTI** - Saranno riconosciuti validi solo i pagamenti effettuati nei modi e nei termini pattuiti. Trascorso il termine di pagamento la CHIARAVALLI GROUP SpA conteggerà gli interessi di mora al tasso del 3% superiore a quello legale, fermo il diritto di esigere il pagamento. In caso di ritardato o mancato pagamento da parte del committente la ditta CHIARAVALLI GROUP SpA si riserva il diritto di sospendere le consegne degli ordini in corso o di pretendere il pagamento anticipato senza riconoscere al committente indennizzi di sorta o risarcimenti. Qualsiasi contestazione dei materiali in corso di fabbricazione o già in possesso del committente non libera quest'ultimo dall'effettuare il pagamento alla scadenza stabilita e per l'intero ammontare della fattura senza alcuna detrazione.

**10) PROPRIETÀ** - Tutta la merce spedita rimane sempre di proprietà della Ditta CHIARAVALLI GROUP SpA fino al pagamento completo delle sue fatture.

**11) FORO COMPETENTE** - Qualsiasi controversia inerente ai rapporti commerciali con la CHIARAVALLI GROUP SpA sarà di competenza del Tribunale di Busto Arsizio.

Chiaravalli Group SpA declina qualsiasi responsabilità per eventuali errori in cui possa essere incorsa nella compilazione del presente catalogo e si riserva il diritto di apporre ai disegni ed alle dimensioni dei prodotti elencati qualunque modifica richiesta da esigenze di costruzione o dallo sviluppo evolutivo del prodotto.

*for damages that occur during the use of their products, even if defective. Warranty is excluded for leakage of lubricant caused by wear of the oil seals.*

**8) RESPONSIBILITY** - CHIARAVALLI GROUP SpA does not accept responsibility or pay any reimbursement for damages that occur during the use of their products, even if defective. CHIARAVALLI GROUP SpA declines all responsibility in the execution of parts to a client's design under any patents.

**9) PAYMENTS** - Only payments carried out in the manner and terms agreed will be considered valid. Once the due date of payment has passed, CHIARAVALLI GROUP SpA will calculate the interest on delayed payment at a rate that is 3% higher than the legal one, retaining the right to demand payment. In the event of delayed or missing payment by the purchaser, the company CHIARAVALLI GROUP SpA reserves the right to suspend deliveries of the orders in course or to demand advance payment without having to pay any reimbursement or compensation to the purchaser. Any dispute regarding materials in manufacture or already possessed by the purchaser does not free the latter from the commitment of making the payment by the agreed date and for the whole amount of the invoice without making any deductions.

**10) OWNERSHIP** - All of the goods despatched remain the property of CHIARAVALLI GROUP SpA until the invoice is fully paid.

**11) COMPETENT COURT** - Any controversy concerning business relations with CHIARAVALLI GROUP SpA will be dealt with under the jurisdiction of the Court of Busto Arsizio.

*Chiaravalli Group SpA accepts no responsibility for any errors in the production of this catalogue and reserves the right to add to the designs or dimensions of the listed products any modification called for by manufacturing requirements or due to evolution of the product.*

# SHIPPING SERVICES



B2B

*Chiaravalli Group SpA  
E-commerce service*

FAST TRACK

*Daily Shipments*



PRIORITY TRACK SERVICE

*Full truck priority Shipments*

ADVANCED SHIPPING

*Thirty hours Shipments*



***YOUR SINGLE NEED IS OUR PRIORITY***