

SPANN-BOY®

with arc segment profile



Applications

For applications with restricted free space beneath the chain. 30 mm are sufficient.

Tensioning pressure

- Choice of light or heavy spring force

Attachment

- Installed next to the chain
- Bore holes in the housing

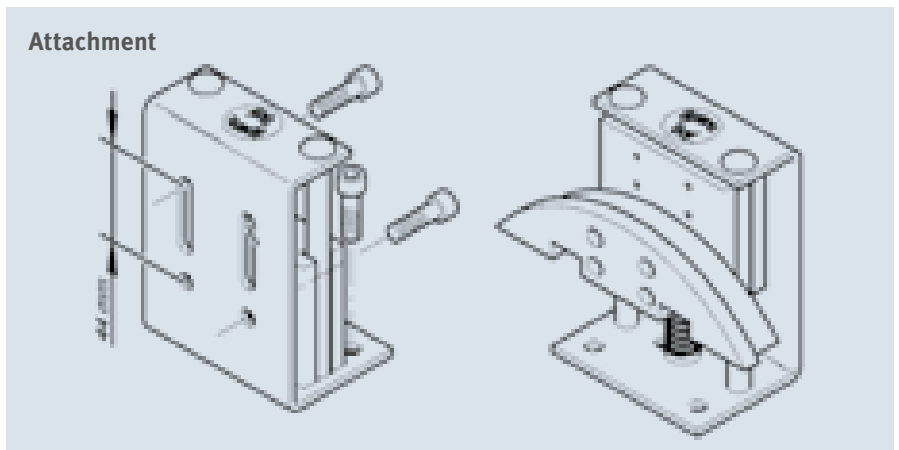

DIN 8187 chain no.	B	a	Light tension force article no.	Heavy tension force article no.	Heavy tension force, stainless steel article no.	Availability
≤06B-1 (U profile)	20	10.0	281 040 001	281 040 002	282 040 002	●
08B-1	20	16.5	281 040 003	281 040 004	282 040 004	●
10B-1	20	15.6	281 040 005	281 040 006	282 040 006	●
12B-1	20	14.8	281 040 007	281 040 008	282 040 008	●
06B-2	20	7.5	281 040 009	281 040 010	282 040 010	○
08B-2	32	15.2	281 040 011	281 040 012	282 040 012	●
10B-2	32	11.3	281 040 013	281 040 014	282 040 014	●
05B-3	20	7.4	281 040 015	281 040 016	282 040 016	○
06B-3	32	9.4	281 040 017	281 040 018	282 040 018	○

Special designs on request

● Stocked ○ Available within 10 days Dimensions in mm

