

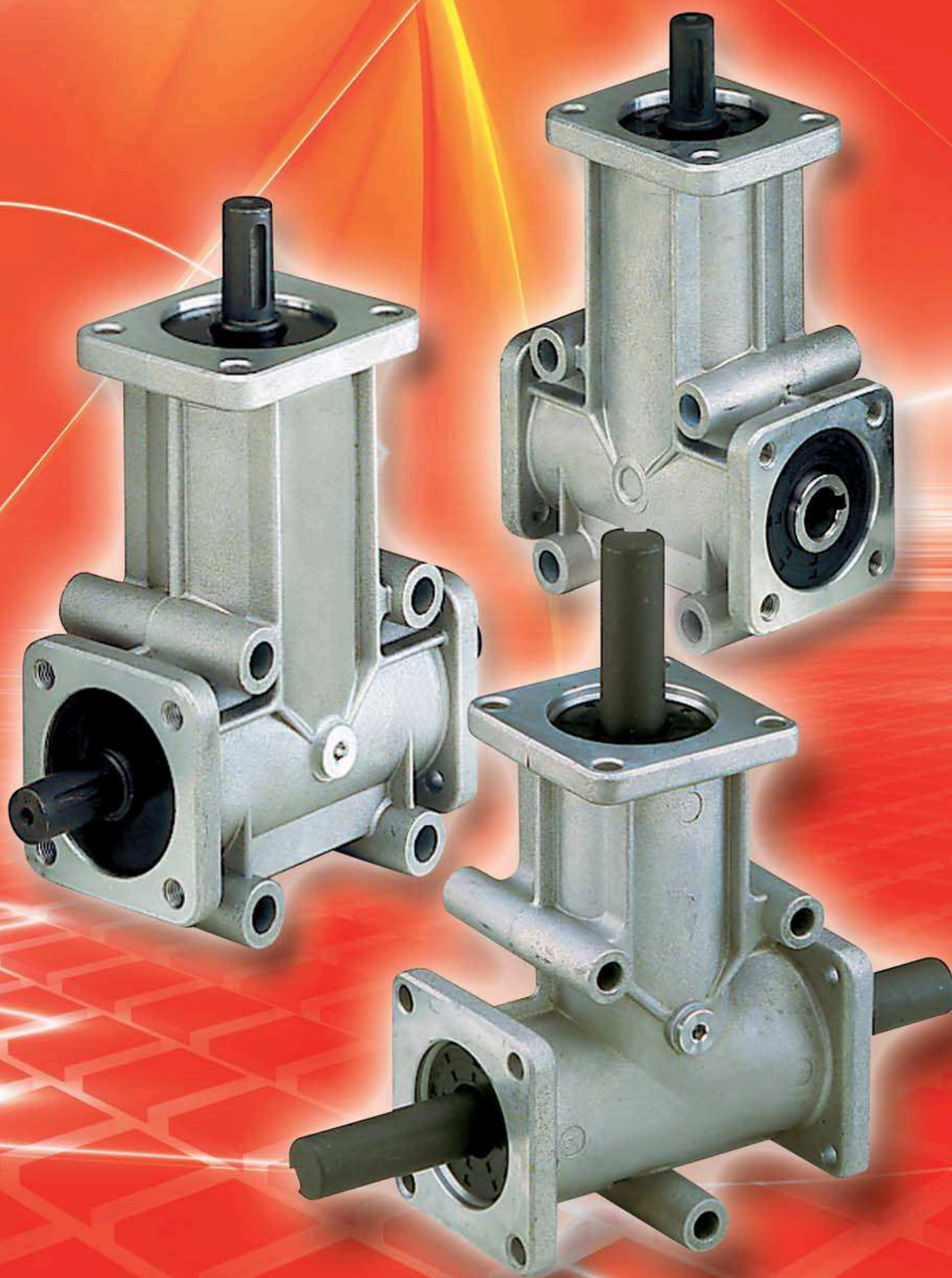

CHIARAVALLI CZ s.r.o.



KUŽELOVÉ PŘEVODOVKY SÉRIE CHT-RP, CHT-RB
CHT-RP, CHT-RB RIGHT-ANGLE PRECISION BEVEL
GEAR DRIVES

KUŽELOVÉ PŘEVODOVKY

RIGHT-ANGLE PRECISION BEVEL GEAR DRIVES

Kuželové převodovky CHT-RB a CHT-RP jsou vyvinuty pro průmyslové aplikace, kde je zapotřebí převést rotační pohyb mezi dvěma pravouhlými osami. CHT-RB a CHT-RP kuželové převodovky jsou k dispozici v mnoha různých velikostech s 2 nebo 3 výstupy a 1/1 - 1/2 - 1/3 převodovými poměry.

Identifikace kuželové převodovky:

Následující tabulka znázorňuje: průměr hřídele, převodový poměr, vstupní hřídel, výstupní hřídel B-C nebo D a směr otáčení (při pohledu na hřídele z přední strany).

CHT-RB and CHT-RP right-angle drives are designed for industrial applications where rotary power must be transferred between two shafts at right-angles to each other. CHT-RB and CHT-RP are available in many different sizes with 2 or 3 outputs and 1/1 - 1/2 - 1/3 transmission ratios.

Right-angle identification:

The following tables show: the shaft diameter, the transmission ratio, the input shaft, the output shafts B-C or D and the direction of rotation (looking at the shaft from the front)

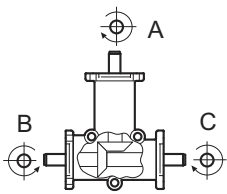
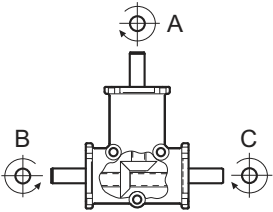
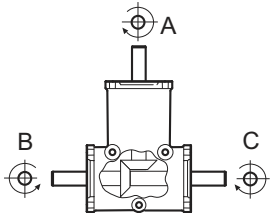
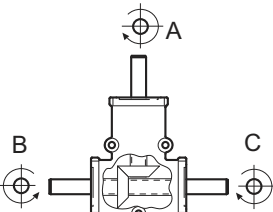
VELIKOST SIZE	MOD. RB	CHT						
		HŘÍDEL SHAFT	PŘEVOD RATIO	VSTUP INPUT	VÝSTUP OUTPUT	TYP TYPE	KÓD CODE	VÁHA Kg. WEIGHT Kg
1		Ø 8	1/1	A	B	1	R1081101	0.3
		Ø 8	1/1	A	C	2	R1081102	
		Ø 8	1/2	A	B	3	R1081203	
		Ø 8	1/2	A	C	4	R1081204	
		Ø 8	1/1	A	B-C	5	R1081105	
		Ø 8	1/2	A	B-C	6	R1081206	
2		Ø 15	1/1	A	B	1	R1151101	1.1
		Ø 15	1/1	A	C	2	R1151102	
		Ø 15	1/2	A	B	3	R1151203	
		Ø 15	1/2	A	C	4	R1151204	
		Ø 15	1/1	A	B-C	5	R1151105	1.2
		Ø 15	1/2	A	B-C	6	R1151206	
3		Ø 20	1/1	A	B	1	R1201101	3.4
		Ø 20	1/1	A	C	2	R1201102	
		Ø 20	1/2	A	B	3	R1201203	
		Ø 20	1/2	A	C	4	R1201204	
		Ø 20	1/1	A	B-C	5	R1201105	3.5
		Ø 20	1/2	A	B-C	6	R1201206	
4		Ø 25	1/1	A	B	1	R1251101	5.5
		Ø 25	1/1	A	C	2	R1251102	
		Ø 25	1/2	A	B	3	R1251203	
		Ø 25	1/2	A	C	4	R1251204	
		Ø 25	1/1	A	B-C	5	R1251105	5.8
		Ø 25	1/2	A	B-C	6	R1251206	

KUŽELOVÉ PŘEVODOVKY RIGHT-ANGLE PRECISION BEVEL GEAR DRIVES

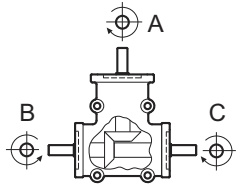
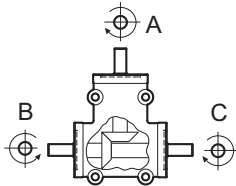
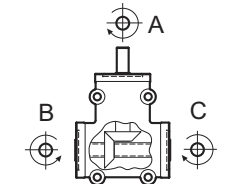
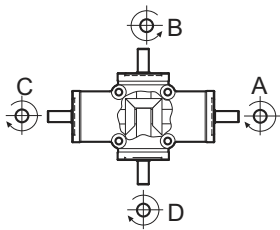
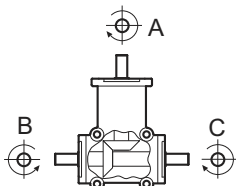
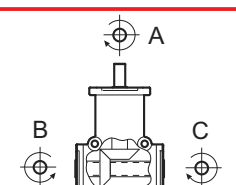
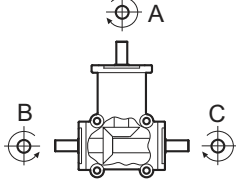
VELIKOST SIZE	MOD. RP	CHT						VÁHA Kg. WEIGHT Kg
	HŘÍDEL SHAFT	PŘEVOD RATIO	VSTUP INPUT	VÝSTUP OUTPUT	TYP TYPE	KÓD CODE		
1		Ø 8	1/1	A	B	1	R3081101	0.6
		Ø 8	1/1	A	C	2	R3081102	
		Ø 8	1/2	A	B	3	R3081203	
		Ø 8	1/2	A	C	4	R3081204	
		Ø 8	1/1	A	B-C	5	R3081105	
		Ø 8	1/2	A	B-C	6	R3081206	
2		Ø 14	1/1	A	B	1	R3141101	2
		Ø 14	1/1	A	C	2	R3141102	
		Ø 14	1/2	A	B	3	R3141203	
		Ø 14	1/2	A	C	4	R3141204	
		Ø 14	1/3	A	B	5	R3141305	
		Ø 14	1/3	A	C	6	R3141306	
		Ø 14	1/1	A	B-C	7	R3141107	
		Ø 14	1/2	A	B-C	8	R3141208	
		Ø 14	1/3	A	B-C	9	R3141309	
3		Ø 14	1/1	A	B-C	10	R3141110	1.9
		Ø 14	1/2	A	B-C	11	R3141211	
		Ø 14	1/3	A	B-C	12	R3141312	
4		Ø 14	1/1	A	B-C	13	R3141113	3.2
		Ø 14	1/1	A	C-D	14	R3141114	
		Ø 14	1/2	A	B-C	15	R3141215	
		Ø 14	1/2	A	C-D	16	R3141216	
		Ø 14	1/3	A	B-C	17	R3141317	
		Ø 14	1/3	A	C-D	18	R3141318	
		Ø 14	1/1	A	B-C-D	19	R3141119	
		Ø 14	1/2	A	B-C-D	20	R3141220	
		Ø 14	1/3	A	B-C-D	21	R3141321	
5		Ø 19	1/1	A	B	1	R3191101	4.5
		Ø 19	1/1	A	C	2	R3191102	
		Ø 19	1/2	A	B	3	R3191203	
		Ø 19	1/2	A	C	4	R3191204	
		Ø 19	1/3	A	B	5	R3191305	
		Ø 19	1/3	A	C	6	R3191306	
		Ø 19	1/1	A	B-C	7	R3191107	
		Ø 19	1/2	A	B-C	8	R3191208	
		Ø 19	1/3	A	B-C	9	R3141309	
6		Ø 19	1/1	A	B-C	10	R3191110	4.4
		Ø 19	1/2	A	B-C	11	R3191211	
		Ø 19	1/3	A	B-C	12	R3191312	
7		Ø 24	1/1	A	B	1	R3241101	4.6
		Ø 24	1/1	A	C	2	R3241102	
		Ø 24	1/2	A	B	3	R3241203	
		Ø 24	1/2	A	C	4	R3241204	
		Ø 24	1/3	A	B	5	R3241305	
		Ø 24	1/3	A	C	6	R3241306	
		Ø 24	1/1	A	B-C	7	R3241107	
		Ø 24	1/2	A	B-C	8	R3241208	
		Ø 24	1/3	A	B-C	9	R3241309	

ZPŮSOB VOLBY KUŽELOVÉ PŘEVODOVKY

HOW TO SELECT THE CORRECT RIGHT-ANGLE BEVEL GEAR DRIVE FOR YOUR APPLICATION

TECHNICKÉ ÚDAJE

Volba správného typu kuželové převodovky není pouze otázkou definování požadovaného výkonu ve vztahu k otáčkám a přenášeného kroutícího momentu. Volba zahrnuje definování podmínek, za kterých bude kuželová převodovka používána. Definice provozních podmínek zahrnuje vzít v potaz množství faktorů, jako je například typ operačních cyklů (přerušovaný, stálý), radiální a axiální zatížení na koncích hřídelí, maximální a minimální teplotu, podmínky prostředí (např. prašné, špinavé) a použitý typ mazacího prostředku. Pro rozhodnutí o typu a velikosti kuželové převodovky, postupujte následovně.

- 1) Použijte tabulku 2 pro definování servisního faktoru pro Vaši aplikaci.
- 2) Kalkulujte nominální výkon (P_n); $P_n = P_e$ (Koňská síla) $\times F_s$
- 3) Použijte výstupní rychlost a nominální výkon (P_n) pro volbu velikosti kuželové převodovky a převodový poměr požadovaný pro Vaši aplikaci.
- 4) Překontrolujte, že radiální a axiální zatížení na koncích hřídelí nepřekračuje hodnoty uvedené v tabulce 1.
- 5) Překontrolujte, že provozní teplota okolí nepřekročí teplotní rozmezí $-20^\circ\text{C} \div 80^\circ\text{C}$.
- 6) Pokud požadujete převodový poměr 1/2 a 1/3, nepoužívejte rychlostní násobitel se vstupem více jak 750 ot/min a 500 ot/min při poměrech 1/2 a 1/3.
- 7) V případě, že jednotka bude používána v prašném prostředí, ochraňte olejové těsnění proti přímému vystavení prachu, jako ochranu proti brusným škodám, které by mohli způsobit zkrácení životnosti kuželové převodovky.

TECHNICAL NOTES

Selecting the correct type of angle bevel gear is not simply a question of defining the power required in relation to R.P.M. and the torque to be transmitted. It also involves defining the conditions under which the angle bevel gear will be used. Defining operating conditions involves taking into consideration a number of factors such as the type of operating cycle (intermittent, continuous), radial and axial loads on the shaft ends, maximum and minimum temperatures, ambient conditions (e.g. dust and dirt levels) and the type of lubricant used. To decide the type and size of angle bevel gear required, proceed as follows.

- 1) Use table 2 to define the Service Factor for your application.
- 2) Calculate the Rated Power (P_n); $P_n = P_e$ (Horsepower) $\times F_s$.
- 3) Use the output speed and the rated power (P_n) to select the angle gear size and transmission ratio required for your application.
- 4) Check that the radial and axial load at the midpoint of the exposed shaft end does not exceed the values shown in table 1.
- 5) Check that the operating temperature does not exceed $-20^\circ\text{C} \div 80^\circ\text{C}$.
- 6) If you require a 1/2 or 1/3 ratio, do not use a speed multiplier with an input more than 750 R.P.M. and 500 R.P.M. in ratio 1/2 and 1/3, respectively.
- 7) If the unit is to be used in very dusty conditions, protect the oil seal against direct exposure to dust to prevent abrasive damage which might shorten the working life of the unit.

TABULKA 1 - TABLE 1

MAXIMÁLNÍ RADIÁLNÍ A AXIÁLNÍ ZATÍŽENÍ

MAX RADIAL AND AXIAL LOADS

VELIKOST SIZE	MAX.AXIÁLNÍ ZATÍŽENÍ V Kg. MAX AXIAL LOAD IN Kg.	MAX.RADIÁLNÍ ZATÍŽENÍ Kg. MAX RADIAL LOAD IN Kg.
RB1	21	11
RB2	41	20
RB3	76	43
RB4	88	49
RP1	28	15
RP2-3/4	53	30
RP5-6	65	45
RP7	80	60

TABULKA 2 - TABLE 2

SERVISNÍ FAKTOR F_s

SERVICE FACTOR F_s

	počet hodin provozu za den hours of operation for day			
	3	8	12	24
jednotné zatížení uniform load	0.7	0.9	1	1.3
zatížení s mírnými rázy load with moderate shocks	0.9	1	1.3	1.8
zatížení s rázy load with shocks	1.3	1.6	1.8	2.3



VSTUPNÍ VÝKON (Pn) Výstupní kroutící moment T (vstupní hřídel/input shaft A) INPUT POWER (Pn) Output torque T

Výstupní otáčky Output speed		50 ot/min	100 ot/min	200 ot/min	400 ot/min	800 ot/min	1400 ot/min	2000 ot/min	3000 ot/min		
Výstupní kr.moment Output torque		T výkon power		T výkon power		T výkon power		T výkon power		T výkon power	
Typ Type	Převod Ratio	Nm Kw	Nm Kw	Nm Kw	Nm Kw	Nm Kw	Nm Kw	Nm Kw	Nm Kw	Nm Kw	
RB 1-1/2- RB 1-5	R 1:1	4,7 0,02	3,9 0,04	3,3 0,07	2,8 0,12	2,3 0,19	2,0 0,30	1,8 0,39	1,7 0,53		
RP 1-1/2- RP 1-5		9,1 0,05	7,6 0,08	6,4 0,13	5,4 0,23	4,5 0,38	4,0 0,58	3,6 0,76	3,3 1,03		
RB 2-1/2- RB 2-5		16,5 0,09	13,9 0,15	11,7 0,24	9,8 0,41	8,2 0,69	7,2 1,05	6,6 1,37	5,9 1,86		
RP 3-10		28,8 0,15	24,2 0,25	20,3 0,43	17,1 0,72	14,4 1,20	12,5 1,83	11,4 2,39	10,3 3,25		
RP 2-1/2		34,5 0,18	29,0 0,30	24,4 0,51	20,5 0,86	17,2 1,44	15,0 2,20	13,7 2,87	12,4 3,89		
RP 4-13/14											
RP 2-7											
RP 4-19		53,1 0,28	44,6 0,47	37,5 0,79	31,6 1,32	26,5 2,22	23,1 3,38	21,1 4,42	19,1 5,99		
RB 3-1/2											
RB 3-5											
RP 6-10	75,7 0,40	63,7 0,67	53,5 1,12	45,0 1,89	37,9 3,17	32,9 4,82	30,1 6,30	27,2 8,54			
RB 4-1/2 - RP 5-1/2	87,3 0,46	73,4 0,77	61,8 1,29	51,9 2,17	43,7 3,66	38,0 5,56	34,7 7,27	31,4 9,86			
RP 7-1/2- RB 4-5											
RP 5-7- RP 7-7											
RB 1-3/4- RB 1-6	R 1:2	4,0 0,02	3,4 0,04	2,8 0,06	2,4 0,10	2,0 0,17	1,7 0,26	1,6 0,33	1,4 0,45		
RP 1-3/4- RP 1-6		8,9 0,05	7,5 0,08	6,3 0,13	5,3 0,22	4,4 0,37	3,9 0,57	3,5 0,74	3,2 1,00		
RB 2-3/4- RB 2-6		14,6 0,08	12,3 0,13	10,3 0,22	8,7 0,36	7,3 0,61	6,3 0,93	5,8 1,21	5,2 1,65		
RP 3-11		28,1 0,15	23,7 0,25	19,9 0,42	16,7 0,70	14,1 1,18	12,2 1,79	11,2 2,34	10,1 3,17		
RP 2-3/4		33,8 0,18	28,5 0,30	23,9 0,50	20,1 0,84	16,9 1,42	14,7 2,16	13,5 2,82	12,2 3,82		
RP 4-15/16											
RP 2-8											
RP 4-20		42,5 0,22	35,7 0,37	30,1 0,63	25,3 1,06	21,3 1,78	18,5 2,71	16,9 3,54	15,3 4,80		
RB 3-3/4- RB 3-6											
RP 6-11											
RB 4-3/4 - RP 4-6	82,3 0,43	69,2 0,72	58,2 1,22	48,9 2,05	41,1 3,44	35,8 5,24	32,7 6,85	29,6 9,28			
RP 7-3/4- RB 4-6											
RP 5-8- RP 7-8											
RP 2-5/6	R 1:3	27,5 0,14	23,1 0,24	19,4 0,41	16,3 0,68	13,7 1,15	12,0 1,75	10,9 2,29	9,9 3,10		
RP 2-9											
RP 3-12											
RP 4-17/18											
RP 4-21											
RP 5-5/6	63,4 0,33	53,3 0,56	44,9 0,94	37,7 1,58	31,7 2,66	27,6 4,04	25,2 5,28	22,8 7,16			
RP 5-9											
RP 6-12											
RP 7-5/6											
RP 7-9											



KUŽELOVÉ PŘEVODOVKY RIGHT-ANGLE PRECISION BEVEL GEAR DRIVES

EXTERNÍ ZATÍŽENÍ VE VZTAHU K RYCHLOSTI Fr = radiální zatížení Fa = axiální zatížení
EXTERNAL LOADS IN CONNECTION WITH SPEED Fr = radial load Fa = axial load

Výstupní otáčky Output speed		50 ot/min		100 ot/min		200 ot/min		400 ot/min		800 ot/min		1400 ot/min		2000 ot/min		3000 ot/min	
Radiální - axiální zatížení Radial - axial load		Fr	Fa	Fr	Fa	Fr	Fa	Fr	Fa	Fr	Fa	Fr	Fa	Fr	Fa	Fr	Fa
Typ Type	Převod Ratio	N	N	N	N	N	N	N	N	N	N	N	N	N	N	N	N
RB 1-1/2- RB 1-5	R 1:1	139	94	117	79	98	66	83	56	70	47	60	41	55	37	50	34
RP 1-1/2- RP 1-5		195	158	164	133	138	112	116	94	98	79	85	69	78	63	70	57
RB 2-1/2- RB 2-5		328	220	276	185	232	156	195	131	164	110	142	96	130	87	118	79
RP 3-10		430	348	361	293	304	246	256	207	215	174	187	151	171	139	154	125
RP 2-1/2		516	418	434	351	365	295	307	248	258	209	224	182	205	166	185	150
RP 4-13/14																	
RP 2-7																	
RP 4-19																	
RB 3-1/2		684	458	575	385	484	324	407	273	342	229	297	199	272	182	246	165
RB 3-5																	
RP 6-10	826	554	695	465	584	391	491	329	413	277	359	241	329	220	297	199	
RB 4-1/2 - RP 5-1/2	953	639	802	537	674	452	567	380	477	319	414	278	379	254	342	229	
RP 7-1/2- RB 4-5																	
RP 5-7- RP 7-7																	
RB 1-3/4- RB 1-6	R 1:2	107	76	90	64	76	54	64	45	54	38	47	33	43	30	39	27
RP 1-3/4- RP 1-6		182	110	153	93	129	78	108	66	91	55	79	48	73	44	66	40
RB 2-3/4- RB 2-6		276	168	232	141	195	119	164	100	138	84	120	73	110	67	99	60
RP 3-11		370	263	311	221	262	186	220	157	185	132	161	114	147	105	133	95
RP 2-3/4		445	316	374	266	315	224	265	188	223	158	194	137	177	126	160	114
RP 4-15/16																	
RP 2-8																	
RP 4-20																	
RB 3-3/4- RB 3-6		548	361	461	303	387	255	326	214	274	180	238	157	218	143	197	130
RP 6-11		696	422	585	355	492	299	414	251	348	211	303	184	277	168	250	152
RB 4-3/4 - RP 4-6	803	483	675	406	568	341	478	287	402	241	349	210	319	192	289	173	
RP 7-3/4- RB 4-6																	
RP 5-8- RP 7-8																	
RP 2-5/6	R 1:3	357	199	301	167	253	141	213	118	179	99	155	86	142	79	128	71
RP 2-9																	
RP 3-12																	
RP 4-17/18																	
RP 4-21																	
RP 5-5/6	619	346	521	291	438	245	368	206	310	173	269	151	246	138	222	124	
RP 5-9																	
RP 6-12																	
RP 7-5/6																	
RP 7-9																	



KUŽELOVÉ PŘEVODOVKY RIGHT-ANGLE PRECISION BEVEL GEAR DRIVES

VELIKOST 1 - SIZE 1 MOD. RB

CHT

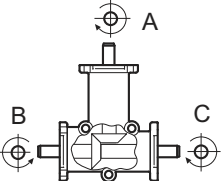
	PŘEVOD RATIO	VSTUP INPUT	VÝSTUP OUTPUT	KÓD CODE	VÁHA Kg WEIGHT Kg
	1/1	A	B	R1081101	0.3
	1/1	A	C	R1081102	
	1/2	A	B	R1081203	
	1/2	A	C	R1081204	
	1/1	A	B-C	R1081105	
	1/2	A	B-C	R1081206	

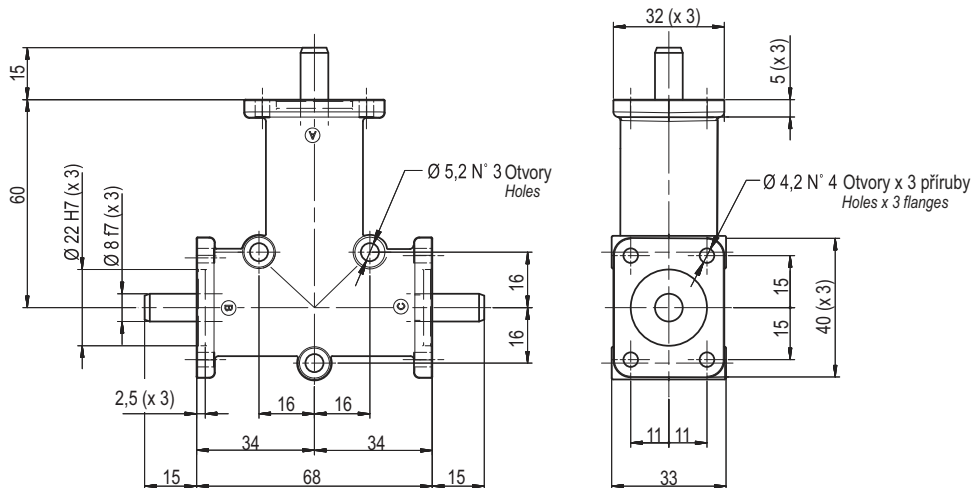

VELIKOST 2 - SIZE 2 MOD. RB

CHT

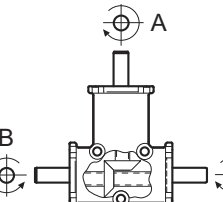
	PŘEVOD RATIO	VSTUP INPUT	VÝSTUP OUTPUT	KÓD CODE	VÁHA Kg WEIGHT Kg
	1/1	A	B	R1151101	1.1
	1/1	A	C	R1151102	
	1/2	A	B	R1151203	
	1/2	A	C	R1151204	
	1/1	A	B-C	R1151105	1.2
	1/2	A	B-C	R1151206	

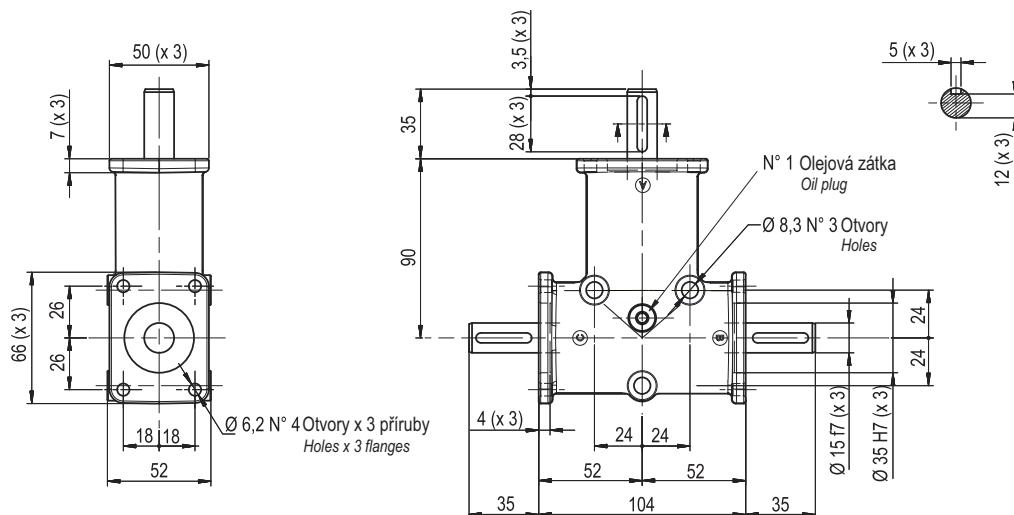

KUŽELOVÉ PŘEVODOVKY RIGHT-ANGLE PRECISION BEVEL GEAR DRIVES

VELIKOST 3 - SIZE 3 MOD. RB

CHT

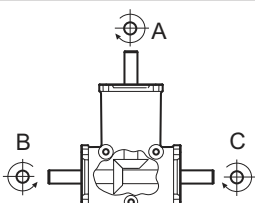
	PŘEVOD RATIO	VSTUP INPUT	VÝSTUP OUTPUT	KÓD CODE	VÁHA Kg WEIGHT Kg
	1/1	A	B	R1201101	3.4
	1/1	A	C	R1201102	
	1/2	A	B	R1201203	
	1/2	A	C	R1201204	
	1/1	A	B-C	R1201105	3.5
	1/2	A	B-C	R1201206	

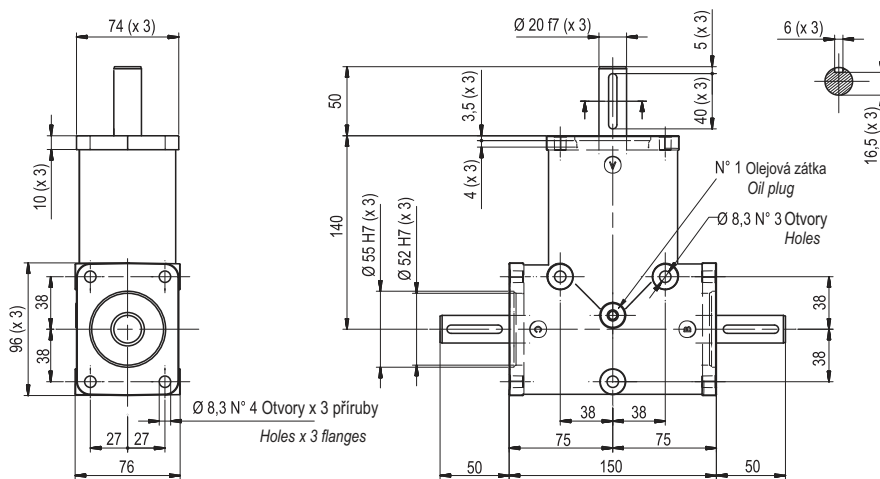

VELIKOST 4 - SIZE 4 MOD. RB

CHT

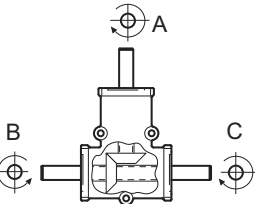
	PŘEVOD RATIO	VSTUP INPUT	VÝSTUP OUTPUT	KÓD CODE	VÁHA Kg WEIGHT Kg
	1/1	A	B	R1251101	5.5
	1/1	A	C	R1251102	
	1/2	A	B	R1251203	
	1/2	A	C	R1251204	
	1/1	A	B-C	R1251105	5.8
	1/2	A	B-C	R1251206	

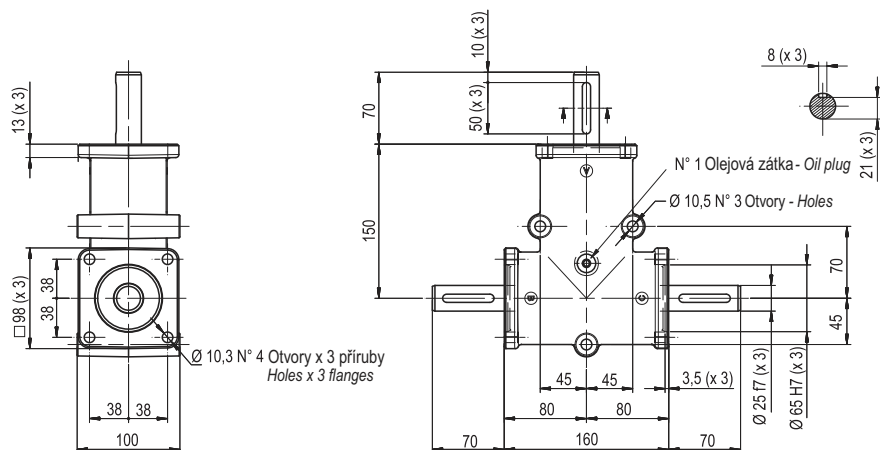

CHIARAVALLI CZ s.r.o.



KUŽELOVÉ PŘEVODOVKY RIGHT-ANGLE PRECISION BEVEL GEAR DRIVES

VELIKOST 1 - SIZE 1 MOD. RP

CHT

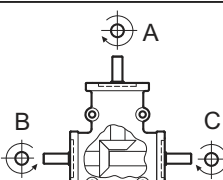
	PŘEVOD RATIO	VSTUP INPUT	VÝSTUP OUTPUT	KÓD CODE	VÁHA Kg WEIGHT Kg
	1/1	A	B	R3081101	0.6
	1/1	A	C	R3081102	
	1/2	A	B	R3081203	
	1/2	A	C	R3081204	
	1/1	A	B-C	R3081105	
	1/2	A	B-C	R3081206	

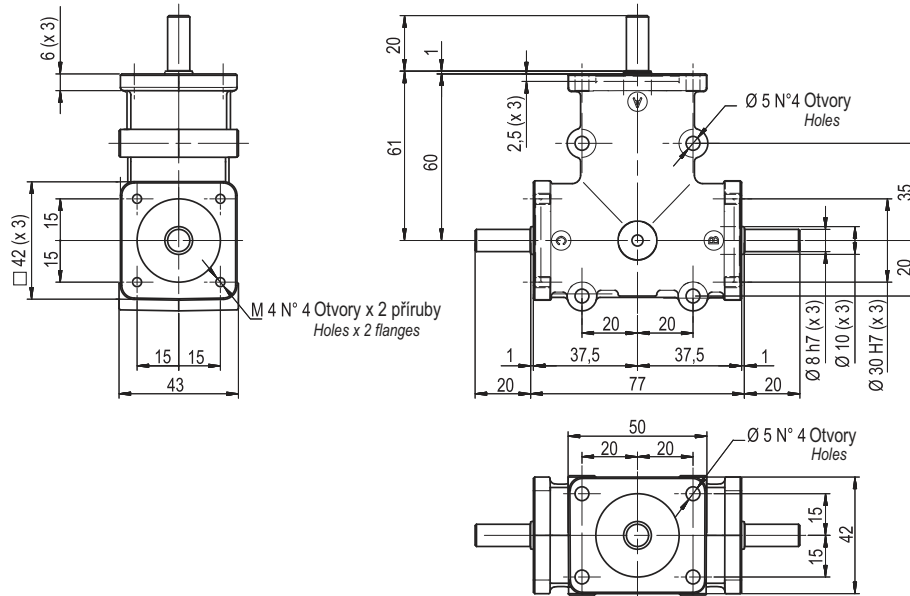

VELIKOST 2 - SIZE 2 MOD. RP

CHT

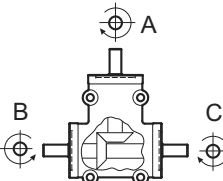
	PŘEVOD RATIO	VSTUP INPUT	VÝSTUP OUTPUT	KÓD CODE	VÁHA Kg WEIGHT Kg
	1/1	A	B	R3141101	2
	1/1	A	C	R3141102	
	1/2	A	B	R3141203	
	1/2	A	C	R3141204	
	1/3	A	B	R3141305	
	1/3	A	C	R3141306	
	1/1	A	B-C	R3141107	
	1/2	A	B-C	R3141208	
	1/3	A	B-C	R3141309	

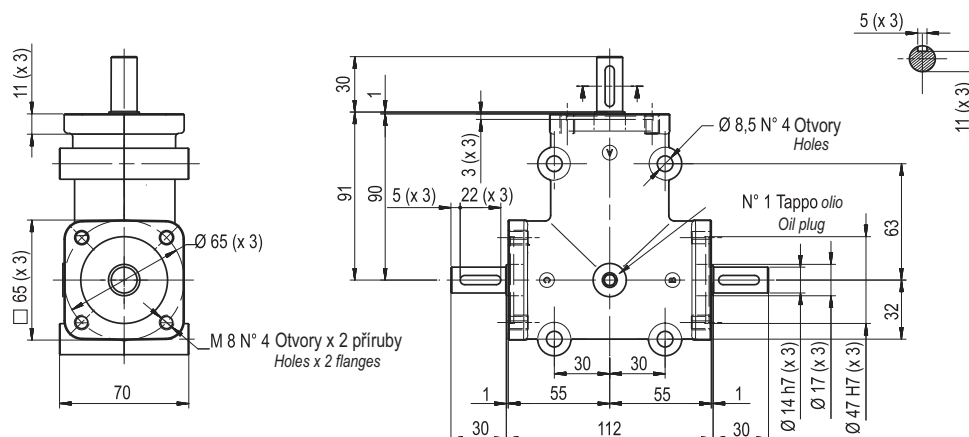

KUŽELOVÉ PŘEVODOVKY RIGHT-ANGLE PRECISION BEVEL GEAR DRIVES

VELIKOST 3 - SIZE 3 MOD. RP

CHT

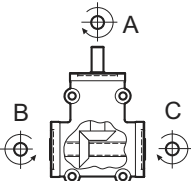
	PŘEVOD RATIO	VSTUP INPUT	VÝSTUP OUTPUT	KÓD CODE	VÁHA Kg WEIGHT Kg
	1/1	A	B-C	R3141110	2
	1/2	A	B-C	R3141211	
	1/3	A	B-C	R3141312	

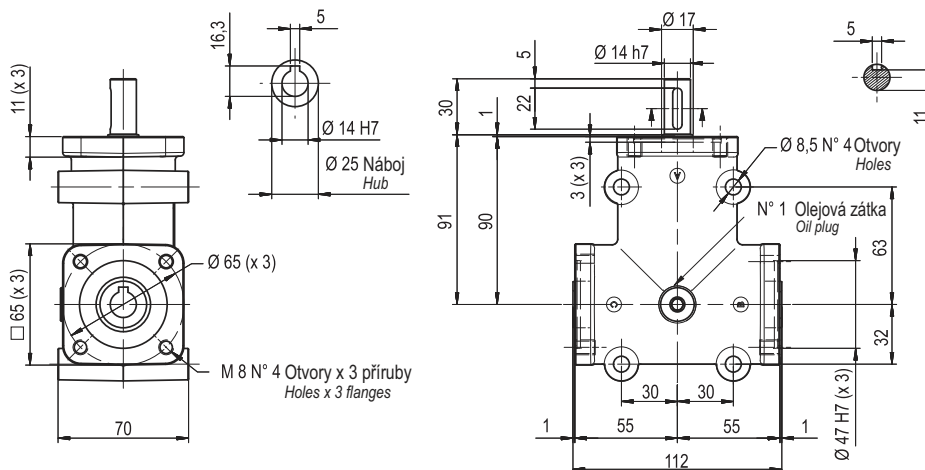

VELIKOST 4 - SIZE 4 MOD. RP

CHT

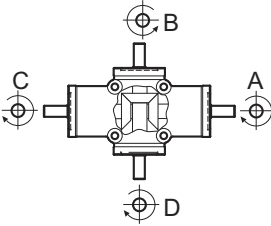
	PŘEVOD RATIO	VSTUP INPUT	VÝSTUP OUTPUT	KÓD CODE	VÁHA Kg WEIGHT Kg
	1/1	A	B-C	R3141113	3.2
	1/1	A	C-D	R3141114	
	1/2	A	B-C	R3141215	
	1/2	A	C-D	R3141216	
	1/3	A	B-C	R3141317	
	1/3	A	C-D	R3141318	
	1/1	A	B-C-D	R3141119	
	1/2	A	B-C-D	R3141220	
	1/3	A	B-C-D	R3141321	

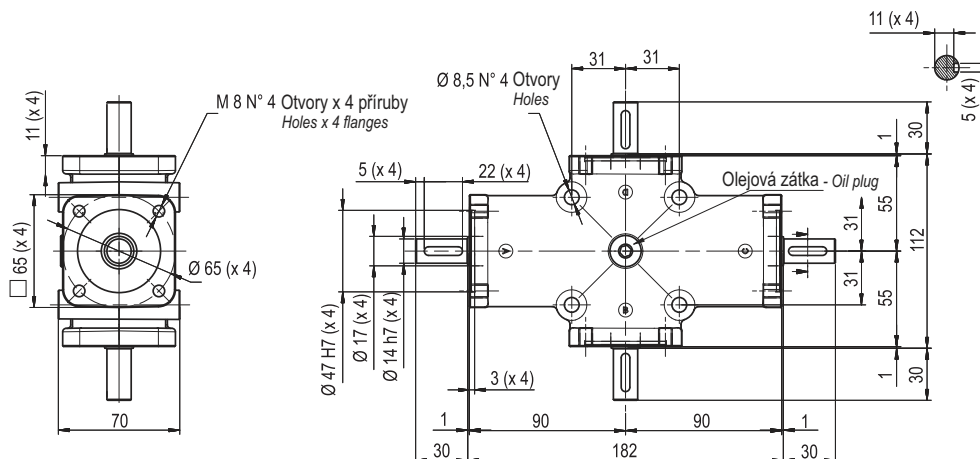

KUŽELOVÉ PŘEVODOVKY RIGHT-ANGLE PRECISION BEVEL GEAR DRIVES

VELIKOST 5 - SIZE 5 MOD. RP

CHT

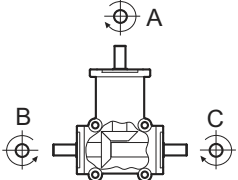
	PŘEVOD RATIO	VSTUP INPUT	VÝSTUP OUTPUT	KÓD CODE	VÁHA Kg WEIGHT Kg
	1/1	A	B	R3191101	4.5
	1/1	A	C	R3191102	
	1/2	A	B	R3191203	
	1/2	A	C	R3191204	
	1/3	A	B	R3191305	
	1/3	A	C	R3191306	
	1/1	A	B-C	R3191107	
	1/2	A	B-C	R3191208	
	1/3	A	B-C	R3191309	

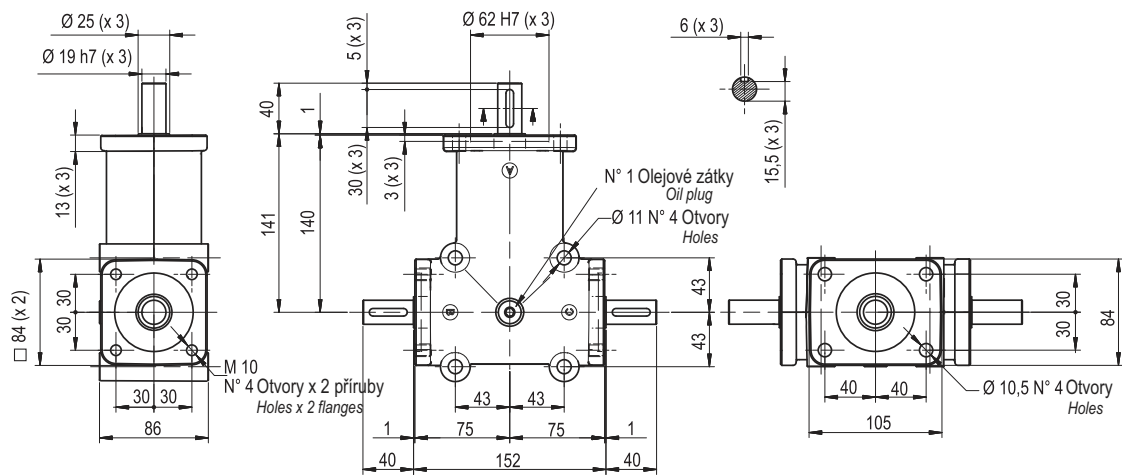

VELIKOST 6 - SIZE 6 MOD. RP

CHT

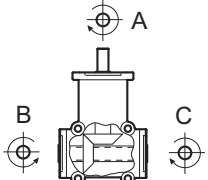
	PŘEVOD RATIO	VSTUP INPUT	VÝSTUP OUTPUT	KÓD CODE	VÁHA Kg WEIGHT Kg
	1/1	A	B-C	R3191110	4.5
	1/2	A	B-C	R3191211	
	1/3	A	B-C	R3191312	

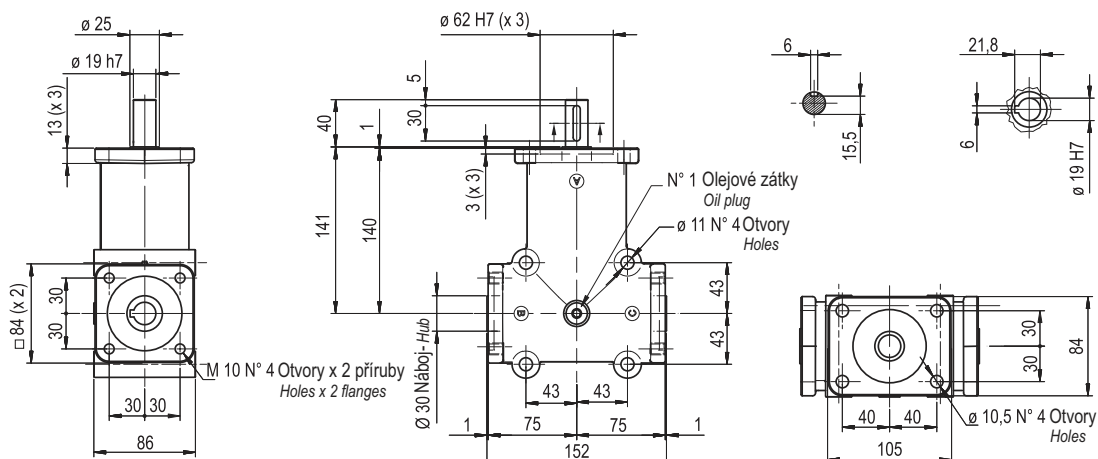

KUŽELOVÉ PŘEVODOVKY RIGHT-ANGLE PRECISION BEVEL GEAR DRIVES

VELIKOST 7 - SIZE 7 MOD. RP

CHT

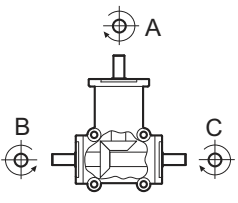
	PŘEVOD RATIO	VSTUP INPUT	VÝSTUP OUTPUT	KÓD CODE	VÁHA Kg WEIGHT Kg
	1/1	A	B	R3241101	4.5
	1/1	A	C	R3241102	
	1/2	A	B	R3241203	
	1/2	A	C	R3241204	
	1/3	A	B	R3241305	
	1/3	A	C	R3241306	
	1/1	A	B-C	R3241107	
	1/2	A	B-C	R3241208	
	1/3	A	B-C	R3241309	

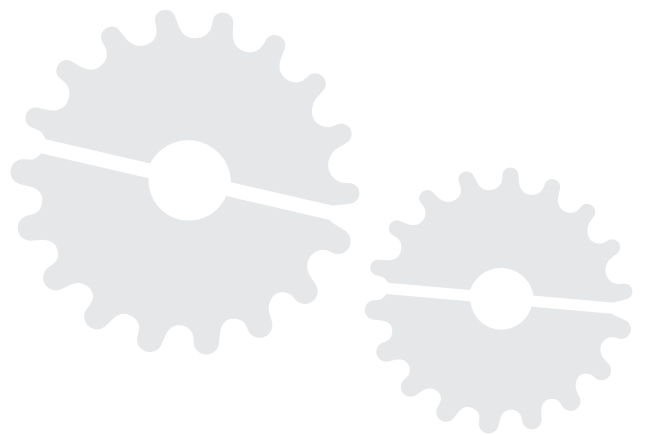
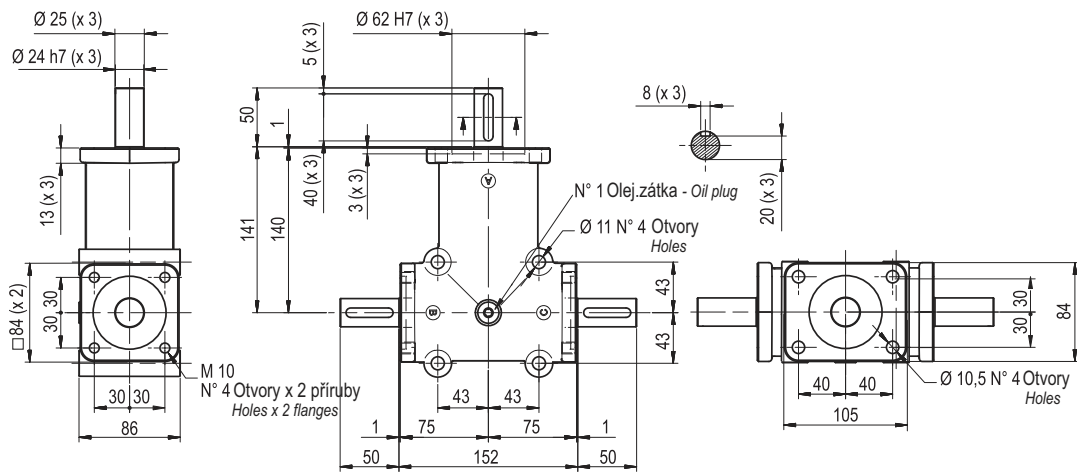

CHIARAVALLI CZ s.r.o.

