

# UPÍNACÍ HŘÍDELOVÁ POUZDRA STANDARDNÍ RCK 19

POZNÁMKA: Doporučené obráběcí tolerance  
jsou následující:  
S průměrem hřídele h 8

DŮLEŽITÉ:  
Vnitřní kónusy jsou mazány pomocí prostředků založených na  
Bisulfid molybdenové bázi.

PŘÍKLAD OBJEDNÁNÍ:  
V případě objednávky pro uložení na hřídel  $\varnothing d$  36 a kroutícím momentem nižším než  
4.900Nm nebo stejným, bude objednán RCK 19 - 36x72.

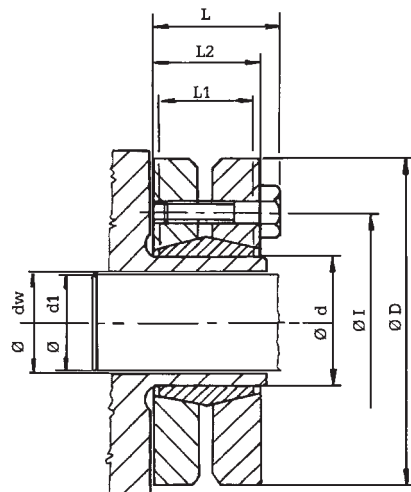

RCK 19

| ROZMĚRY         |                 |                  |    |      |      |                 |                        | Kroučící moment |                             | TLAKY |                            | Upevňovací šrouby<br>DIN 912 MA T. 12.9 |  |  |
|-----------------|-----------------|------------------|----|------|------|-----------------|------------------------|-----------------|-----------------------------|-------|----------------------------|-----------------------------------------|--|--|
| $\varnothing d$ | $\varnothing D$ | $\varnothing dw$ | L1 | L2   | L    | $\varnothing I$ | $\Delta dw$<br>(dw-d1) | Mt<br>Nm        | Hřídel<br>N/mm <sup>2</sup> | Počet | Typ                        | Utahovací<br>moment<br>Nm               |  |  |
| 24              | 50              | 19               | 14 | 19.5 | 23   | 36              | 0.017                  | 170             | 286                         | 6     | M5x18<br>DIN 912 Mat. 12.9 | 4                                       |  |  |
|                 |                 | 20               |    |      |      |                 |                        | 210             |                             |       |                            |                                         |  |  |
|                 |                 | 21               |    |      |      |                 |                        | 250             |                             |       |                            |                                         |  |  |
| 30              | 60              | 24               | 16 | 21.5 | 25   | 44              | 0.017                  | 300             | 233                         | 7     | M5x18<br>DIN 912 Mat. 12.9 | 4                                       |  |  |
|                 |                 | 25               |    |      |      |                 |                        | 340             |                             |       |                            |                                         |  |  |
|                 |                 | 26               |    |      |      |                 |                        | 380             |                             |       |                            |                                         |  |  |
| 36              | 72              | 28               | 18 | 23.5 | 27.5 | 52              | 0.032                  | 440             | 307                         | 5     | M6x20                      | 12                                      |  |  |
|                 |                 | 30               |    |      |      |                 |                        | 570             |                             |       |                            |                                         |  |  |
|                 |                 | 31               |    |      |      |                 |                        | 630             |                             |       |                            |                                         |  |  |
| 44              | 80              | 32               | 20 | 25.5 | 29.5 | 61              | 0.032                  | 620             | 317                         | 7     | M6x20                      | 12                                      |  |  |
|                 |                 | 35               |    |      |      |                 |                        | 780             |                             |       |                            |                                         |  |  |
|                 |                 | 36               |    |      |      |                 |                        | 860             |                             |       |                            |                                         |  |  |
| 50              | 90              | 38               | 22 | 27.5 | 31.5 | 70              | 0.032                  | 940             | 289                         | 8     | M6x25                      | 12                                      |  |  |
|                 |                 | 40               |    |      |      |                 |                        | 1160            |                             |       |                            |                                         |  |  |
|                 |                 | 42               |    |      |      |                 |                        | 1380            |                             |       |                            |                                         |  |  |
| 55              | 100             | 42               | 23 | 30.5 | 34.5 | 75              | 0.032                  | 1160            | 252                         | 8     | M6x25                      | 12                                      |  |  |
|                 |                 | 45               |    |      |      |                 |                        | 1520            |                             |       |                            |                                         |  |  |
|                 |                 | 48               |    |      |      |                 |                        | 1880            |                             |       |                            |                                         |  |  |
| 62              | 110             | 48               | 23 | 30.5 | 34.5 | 86              | 0.048                  | 1850            | 279                         | 10    | M6x25                      | 12                                      |  |  |
|                 |                 | 50               |    |      |      |                 |                        | 2200            |                             |       |                            |                                         |  |  |
|                 |                 | 52               |    |      |      |                 |                        | 2400            |                             |       |                            |                                         |  |  |
| 68              | 115             | 50               | 23 | 30.5 | 34.5 | 86              | 0.048                  | 2000            | 255                         | 10    | M6x25                      | 12                                      |  |  |
|                 |                 | 55               |    |      |      |                 |                        | 2500            |                             |       |                            |                                         |  |  |
|                 |                 | 60               |    |      |      |                 |                        | 3150            |                             |       |                            |                                         |  |  |
| 75              | 138             | 55               | 25 | 32.5 | 37.8 | 100             | 0.048                  | 2500            | 273                         | 7     | M8x30                      | 30                                      |  |  |
|                 |                 | 60               |    |      |      |                 |                        | 3200            |                             |       |                            |                                         |  |  |
|                 |                 | 65               |    |      |      |                 |                        | 3950            |                             |       |                            |                                         |  |  |
| 80              | 145             | 60               | 25 | 32.5 | 37.8 | 100             | 0.048                  | 3200            | 256                         | 7     | M8x30                      | 30                                      |  |  |
|                 |                 | 65               |    |      |      |                 |                        | 3900            |                             |       |                            |                                         |  |  |
|                 |                 | 70               |    |      |      |                 |                        | 4600            |                             |       |                            |                                         |  |  |
| 90              | 155             | 65               | 30 | 39   | 44.3 | 114             | 0.048                  | 4750            | 271                         | 10    | M8x35                      | 30                                      |  |  |
|                 |                 | 70               |    |      |      |                 |                        | 6000            |                             |       |                            |                                         |  |  |
|                 |                 | 75               |    |      |      |                 |                        | 7250            |                             |       |                            |                                         |  |  |
| 100             | 170             | 70               | 34 | 44   | 49.3 | 124             | 0.048                  | 6900            | 258                         | 12    | M8x35                      | 30                                      |  |  |
|                 |                 | 75               |    |      |      |                 |                        | 7500            |                             |       |                            |                                         |  |  |
|                 |                 | 80               |    |      |      |                 |                        | 9000            |                             |       |                            |                                         |  |  |
| 110             | 185             | 75               | 39 | 50   | 56.4 | 136             | 0.048                  | 7200            | 244                         | 9     | M10x40                     | 59                                      |  |  |
|                 |                 | 80               |    |      |      |                 |                        | 9000            |                             |       |                            |                                         |  |  |
|                 |                 | 85               |    |      |      |                 |                        | 10800           |                             |       |                            |                                         |  |  |
| 125             | 215             | 85               | 42 | 54   | 60.4 | 160             | 0.069                  | 11000           | 266                         | 12    | M10x40                     | 59                                      |  |  |
|                 |                 | 90               |    |      |      |                 |                        | 13000           |                             |       |                            |                                         |  |  |
|                 |                 | 95               |    |      |      |                 |                        | 15000           |                             |       |                            |                                         |  |  |
| 140             | 230             | 95               | 46 | 60.5 | 68   | 175             | 0.069                  | 15100           | 264                         | 10    | M12x45                     | 100                                     |  |  |
|                 |                 | 100              |    |      |      |                 |                        | 17600           |                             |       |                            |                                         |  |  |
|                 |                 | 105              |    |      |      |                 |                        | 20100           |                             |       |                            |                                         |  |  |
| 155             | 265             | 105              | 50 | 64.5 | 72   | 192             | 0.069                  | 22000           | 263                         | 12    | M12x50                     | 100                                     |  |  |
|                 |                 | 110              |    |      |      |                 |                        | 25000           |                             |       |                            |                                         |  |  |
|                 |                 | 115              |    |      |      |                 |                        | 28000           |                             |       |                            |                                         |  |  |
| 165             | 290             | 115              | 56 | 71   | 81   | 210             | 0.069                  | 31000           | 277                         | 8     | M16x55                     | 250                                     |  |  |
|                 |                 | 120              |    |      |      |                 |                        | 35000           |                             |       |                            |                                         |  |  |
|                 |                 | 125              |    |      |      |                 |                        | 39000           |                             |       |                            |                                         |  |  |
| 175             | 300             | 125              | 56 | 71   | 81   | 220             | 0.079                  | 36000           | 261                         | 8     | M16x55                     | 250                                     |  |  |
|                 |                 | 130              |    |      |      |                 |                        | 41000           |                             |       |                            |                                         |  |  |
|                 |                 | 135              |    |      |      |                 |                        | 45000           |                             |       |                            |                                         |  |  |
| 185             | 330             | 135              | 71 | 86   | 96   | 236             | 0.090                  | 52000           | 237                         | 10    | M16x70                     | 250                                     |  |  |
|                 |                 | 140              |    |      |      |                 |                        | 57000           |                             |       |                            |                                         |  |  |
|                 |                 | 145              |    |      |      |                 |                        | 62000           |                             |       |                            |                                         |  |  |